

BROUGHT TO YOU BY PRO GEAR &
TRANSMISSION.

FOR PARTS OR SERVICE CALL:

877-776-4600

407-872-1901



Roadranger®



EATON

SPICER®



WWW.PGTTRUCKPARTS.COM

906 W. GORE ST. ORLANDO, FL 32805
PARTS@EPROGEAR.COM

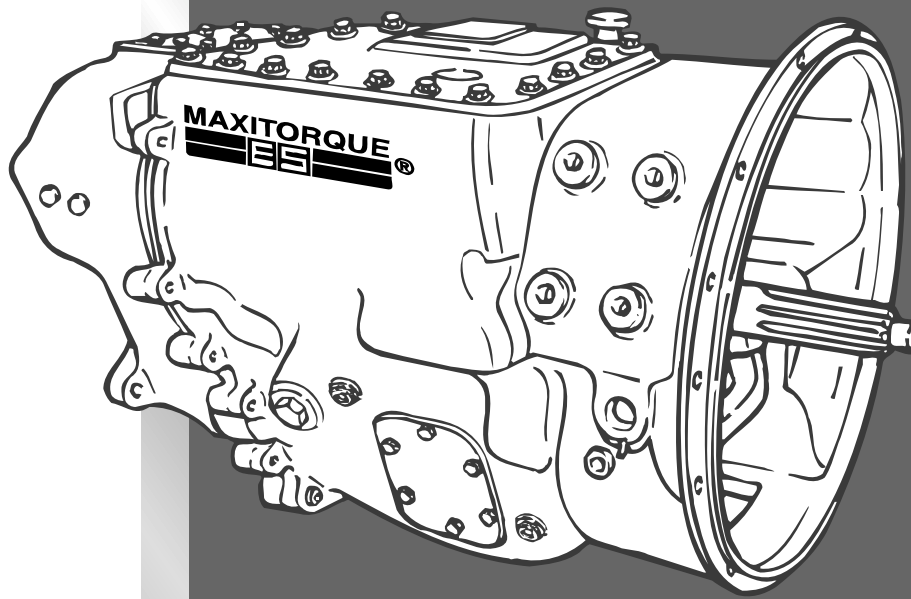

MAXITORQUE[®]
ES

TRANSMISSION

T310

SERVICE MANUAL



APRIL 2003
(NEW ISSUE)
10-126

For parts or service call us
Pro Gear & Transmission, Inc.



1 (877) 776-4600

(407) 872-1901

parts@eprogear.com

906 W. Gore St.

Orlando, FL 32805



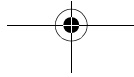
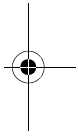
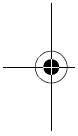



PLEASE LET US KNOW!

Your comments and suggestions will help
us improve this manual!

Please complete and mail this form or FAX
your comments to: (610) 709-3800.

Manual: _____ Publication Number: _____

Vehicle Model: _____ Model Year: _____

Do you find procedures properly organized and easy to follow? Yes No

If not, please explain: _____

Manual page numbers: _____

Are there any important procedures or other information presently not in this
manual that you would like to see included? Yes No

If yes, please describe: _____

Did you find any errors in the procedures or illustrations? Yes No

If yes, what pages? _____

Please explain: _____

Please include a copy of each page in question and mark your comments and
suggestions.

Name: _____ Phone: (_____) _____ - _____

Company: _____

Address: _____

City: _____ State: _____ Zip: _____

Position Title: _____

Thank You For Your Assistance
Mack Trucks, Inc.

(ATTENTION: RTS STAFF, 6S3)

DO NOT STAPLE — USE TRANSPARENT TAPE

FOLD ALONG THIS LINE • DO NOT STAPLE • USE TRANSPARENT TAPE

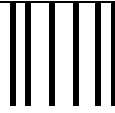

NO POSTAGE
NECESSARY
IF MAILED
IN THE
UNITED STATES

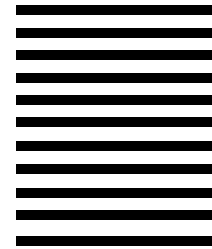

BUSINESS REPLY MAIL
FIRST CLASS MAIL PERMIT NO. 1602 ALLENTOWN, PA

POSTAGE WILL BE PAID BY ADDRESSEE
SERVICE PUBLICATIONS (RTS), 6S3
MACK TRUCKS INC
WORLD HEADQUARTERS
PO BOX M
ALLENTOWN PA 18105-9972



FOLD ALONG THIS LINE



MAXITORQUE[®]
ES
TRANSMISSION
T310
SERVICE MANUAL

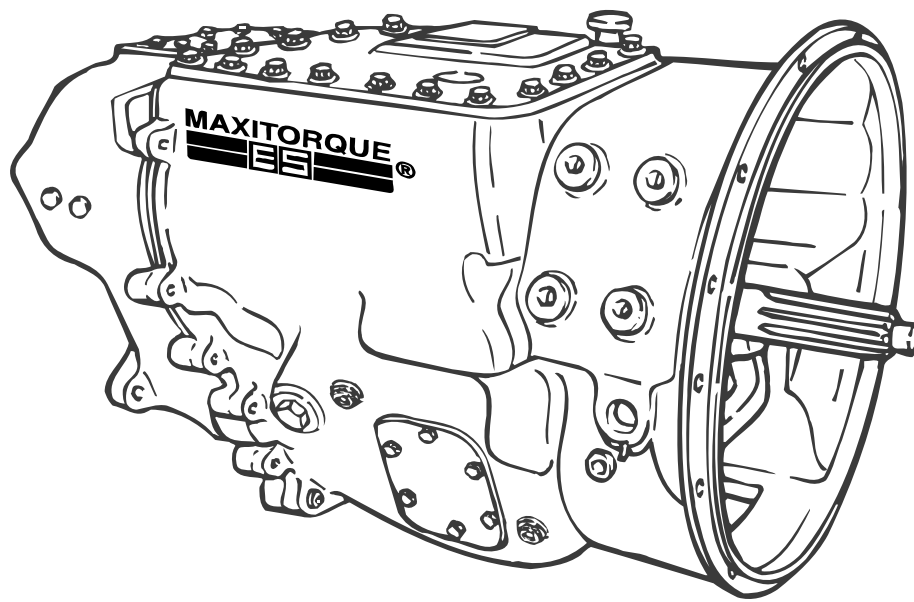

APRIL 2003
(NEW ISSUE)

© MACK TRUCKS, INC. 2003
10-126



ATTENTION

The information in this manual is not all inclusive and cannot take into account all unique situations. Note that some illustrations are typical and may not reflect the exact arrangement of every component installed on a specific chassis.

The information, specifications, and illustrations in this publication are based on information that was current at the time of publication.

No part of this publication may be reproduced, stored in a retrieval system, or be transmitted in any form by any means including (but not limited to) electronic, mechanical, photocopying, recording, or otherwise without prior written permission of Mack Trucks, Inc.



TABLE OF CONTENTS

TABLE OF CONTENTS



TABLE OF CONTENTS

INTRODUCTION	1
SAFETY INFORMATION	2
Advisory Labels	2
Service Procedures and Tool Usage	3
EXPLANATION OF NUMERICAL CODE	5
CONVERSION CHART	6
VISUAL IDENTIFICATION	9
TRANSMISSION IDENTIFICATION	10
Unit Identification Stamping Location	10
DESCRIPTION AND OPERATION	13
DESCRIPTION AND OPERATION	14
T310 Transmissions	14
Lubrication	15
Gear Ratios and Shift Pattern	16
T310 Shifting Instructions	17
Power Flow Diagrams	17
COMPONENT LOCATOR	21
COMPONENT LOCATOR	22
TROUBLESHOOTING	23
TROUBLESHOOTING CHARTS	24
MAINTENANCE	27
TRANSMISSION MAINTENANCE	28
Checking Oil Level	28
Changing Oil	29
Change Interval	29
Draining Oil	29
Oil Fill	29
Magnetic Oil Filter Plug	30
Air Breather	30
REPAIR INSTRUCTIONS	31
TRANSMISSION DISASSEMBLY PROCEDURES	32
TRANSMISSION COMPONENT DISASSEMBLY	51
Main Case Shift Cover Disassembly [323]	51
Two-Position Range Shift Cylinder Disassembly [324]	65
Range Shift Valve [323]	66
Main Drive Pinion Disassembly [322]	68
Front Mainshaft Disassembly [322]	71
Rear Mainshaft and Synchronizer Disassembly [322]	78
Synchronizer Disassembly [322]	81
Rear Mainshaft Bearing Cover Disassembly [321]	83
Compound Main Drive Gear Disassembly [322]	84
Front Countershaft Front Bearing Cover Disassembly [321]	85
Front Countershaft Disassembly [322]	86
Front Countershaft Rear Bearing Cover Disassembly [321]	89
Rear Countershaft Disassembly [322]	90
Rear Countershaft Bearing Cover Disassembly [321]	92
Reverse Idler Gear Disassembly [322]	93



TABLE OF CONTENTS

INSPECTION OF PARTS	94
Inspection and Cleaning	94
Bearings [322]	94
Gears [322]	94
Shifter Forks, Sliding Clutches and Shift Rails [323]	94
Oil Seals [321]	95
General Inspection	96
General Reassembly Instructions	96
TRANSMISSION COMPONENT REASSEMBLY	97
Reverse Idler Gear Reassembly [322]	97
Rear Countershaft Bearing Cover Reassembly [321]	98
Rear Countershaft Reassembly [322]	99
Front Countershaft Rear Bearing Cover Reassembly [321]	100
Front Countershaft Reassembly [322]	101
Front Countershaft Front Bearing Cover Reassembly [321]	105
Compound Main Drive Gear Reassembly [322]	106
Rear Mainshaft Bearing Cover Reassembly [321]	107
Synchronizer Reassembly [322]	109
Rear Mainshaft Reassembly [322]	112
Front Mainshaft Reassembly [322]	116
Main Drive Pinion Reassembly [322]	124
Range Shift Valve [323]	127
Two-Position Range Shift Cylinder Reassembly [324]	129
Main Case Shift Cover Reassembly [323]	134
TRANSMISSION REASSEMBLY PROCEDURES	147
SPECIFICATIONS	169
SPECIFICATIONS	170
Torque Specifications	170
Gear Identification	172
Fits and Limits	174
General Tolerances	175
Transmission Specifications and Capacities	176
SCHEMATIC & ROUTING DIAGRAMS	177
SCHEMATIC DIAGRAMS	178
Air Piping Diagram	178
Air Control Schematic	179
SPECIAL TOOLS & EQUIPMENT	181
SPECIAL TOOLS AND EQUIPMENT	182
Special Tools	182
DISASSEMBLED VIEWS	183
DISASSEMBLED VIEWS	184
INDEX	191



NOTES



INTRODUCTION

INTRODUCTION



INTRODUCTION

SAFETY INFORMATION

Advisory Labels

Cautionary *signal words* (Danger-Warning-Caution) may appear in various locations throughout this manual. Information accented by one of these signal words must be observed to minimize the risk of personal injury to service personnel, or the possibility of improper service methods which may damage the vehicle or cause it to be unsafe. Additional Notes and Service Hints are used to emphasize areas of procedural importance and provide suggestions for ease of repair. The following definitions indicate the use of these advisory labels as they appear throughout the manual:

DANGER

Activities associated with Danger indicate that death or serious personal injury may result from failing to heed the advisory. Serious personal injury may be equated to career-ending injury.

WARNING

Activities associated with Warning indicate that personal injury may result from failing to heed the advisory. In this case, personal injury is not equated to career-ending injury, but results in possible change in quality of life.

CAUTION

Activities associated with Caution indicate that product damage may result from failing to heed the advisory. Caution is not used for personal injury.

NOTE

A procedure, practice, or condition that is essential to emphasize.

SERVICE HINT

A helpful suggestion that will make it quicker and/or easier to perform a procedure, while possibly reducing service cost.



INTRODUCTION

Service Procedures and Tool Usage

Anyone using a service procedure or tool not recommended in this manual must first satisfy himself thoroughly that neither his safety nor vehicle safety will be jeopardized by the service method he selects. Individuals deviating in any manner from the instructions provided assume all risks of consequential personal injury or damage to equipment involved.

Also note that particular service procedures may require the use of a special tool(s) designed for a specific purpose. These special tools must be used in the manner described, whenever specified in the instructions.

⚠ WARNING

1. Before starting a vehicle, always be seated in the driver's seat, place the transmission in neutral, be sure that parking brakes are set, and disengage the clutch.
2. Before working on a vehicle, place the transmission in neutral, set the parking brakes, and block the wheels.
3. Before towing the vehicle, place the transmission in neutral and lift the rear wheels off the ground, or disconnect the driveline to avoid damage to the transmission during towing.

⚠ DANGER

Engine-driven components such as Power Take-Off (PTO) units, fans and fan belts, driveshafts and other related rotating assemblies, can be very dangerous. Do not work on or service engine-driven components unless the engine is shut down. Always keep body parts and loose clothing out of range of these powerful components to prevent serious personal injury. Be aware of PTO engagement or nonengagement status. Always disengage the PTO when not in use.

**REMEMBER,
SAFETY. . . IS NO ACCIDENT!**



INTRODUCTION

Mack Trucks, Inc. cannot anticipate every possible occurrence that may involve a potential hazard. Accidents can be avoided by recognizing potentially hazardous situations and taking necessary precautions. Performing service procedures correctly is critical to technician safety and safe, reliable vehicle operation.

The following list of general shop safety practices can help technicians avoid potentially hazardous situations and reduce the risk of personal injury. **DO NOT** perform any services, maintenance procedures or lubrications until this manual has been read and understood.

- Perform all service work on a flat, level surface. Block wheels to prevent vehicle from rolling.
- **DO NOT** wear loose-fitting or torn clothing. Remove any jewelry before servicing vehicle.
- **ALWAYS** wear safety glasses and protective shoes. Avoid injury by being aware of sharp corners and jagged edges.
- Use hoists or jacks to lift or move heavy objects.
- **NEVER** run engine indoors unless exhaust fumes are adequately vented to the outside.
- Be aware of hot surfaces. Allow engine to cool sufficiently before performing any service or tests in the vicinity of the engine.
- Keep work area clean and orderly. Clean up any spilled oil, grease, fuel, hydraulic fluid, etc.
- Only use tools that are in good condition, and always use accurately calibrated torque wrenches to tighten all fasteners to specified torques. In instances where procedures require the use of special tools which are designed for a specific purpose, use only in the manner described in the instructions.
- Do not store natural gas powered vehicles indoors for an extended period of time (overnight) without first removing the fuel.
- Never smoke around a natural gas powered vehicle.



INTRODUCTION

EXPLANATION OF NUMERICAL CODE

The organization of MACK service manuals has been upgraded to standardize manual content according to a reference system based on component identification. The reference system helps link the information contained in this publication with related information included in other MACK service-warranty publications, such as associated service bulletins, warranty manuals, and MACK Service Labor Time Standards.

The system is based on a numerical code, the first **digit** of which identifies the general component grouping as listed here:

GROUP 000 — GENERAL DATA

GROUP 100 — CHASSIS

GROUP 200 — ENGINE

GROUP 300 — CLUTCH, TRANSMISSION, TRANSFER CASE AND PTO

GROUP 400 — STEERING, AXLES, WHEELS AND TIRES, DRIVELINE

GROUP 500 — BRAKES, AUXILIARY SYSTEMS

GROUP 600 — CAB, TRUCK BODY

GROUP 700 — ELECTRICAL

The second two digits of the 3-digit code are used to identify the **system, assembly** or **subassembly**, as appropriate, within each of the groupings. The codes applicable to this publication are shown at the beginning of each procedure, as necessary, to guide you to specific component information.

Additionally, a two-character alpha code (i.e., [GA] CASE, MAIN) may be shown with each operation. This alpha code, in combination with the three-digit Group number, identifies the specific assembly, subassembly or part, and directly relates to the first five positions of the operation code listed in the MACK Service Labor Time Standards.

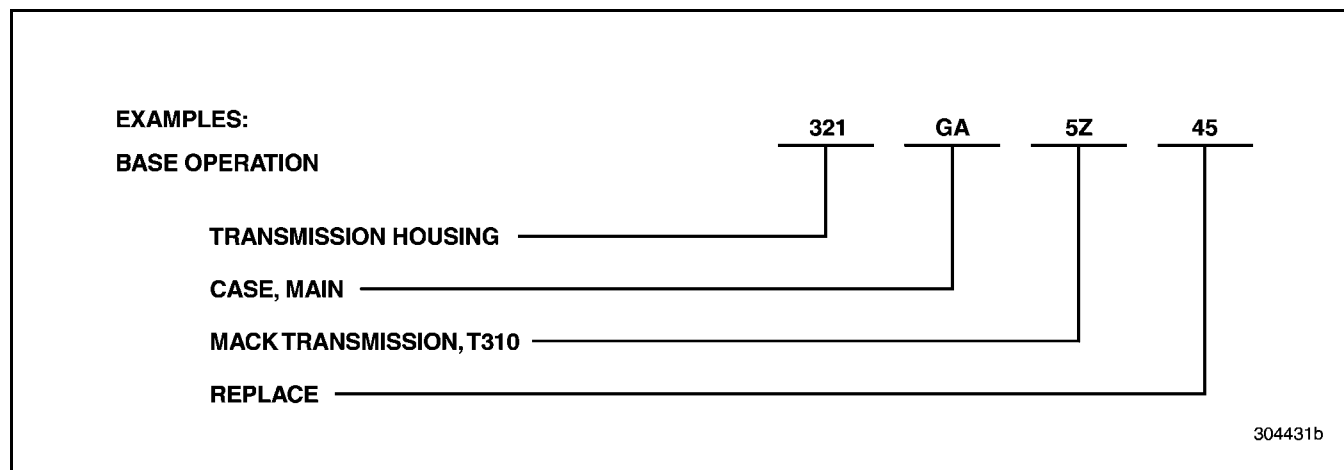

Example of Numerical Code



INTRODUCTION

CONVERSION CHART

Conversion Units			Multiply By:
Length Calculations			
Inches (in)	to	Millimeters (mm)	25.40
Inches (in)	to	Centimeters (cm)	2.540
Feet (ft)	to	Centimeters (cm)	30.48
Feet (ft)	to	Meters (m)	0.3048
Yards (yd)	to	Centimeters (cm)	91.44
Yards (yd)	to	Meters (m)	0.9144
Miles	to	Kilometers (km)	1.609
Millimeters (mm)	to	Inches (in)	0.03937
Centimeters (cm)	to	Inches (in)	0.3937
Centimeters (cm)	to	Feet (ft)	0.0328
Centimeters (cm)	to	Yards (yd)	0.0109
Meters (m)	to	Feet (ft)	3.281
Meters (m)	to	Yards (yd)	1.094
Kilometers (km)	to	Miles	0.6214
Area Calculations			
Square Inches (sq-in)	to	Square Millimeters (sq-mm)	645.2
Square Inches (sq-in)	to	Square Centimeters (sq-cm)	6.452
Square Feet (sq-ft)	to	Square Centimeters (sq-cm)	929.0
Square Feet (sq-ft)	to	Square Meters (sq-m)	0.0929
Square Yards (sq-yd)	to	Square Meters (sq-m)	0.8361
Square Miles (sq-miles)	to	Square Kilometers (sq-km)	2.590
Square Millimeters (sq-mm)	to	Square Inches (sq-in)	0.00155
Square Centimeters (sq-cm)	to	Square Inches (sq-in)	0.155
Square Centimeters (sq-cm)	to	Square Feet (sq-ft)	0.001076
Square Meters (sq-m)	to	Square Feet (sq-ft)	10.76
Square Meters (sq-m)	to	Square Yards (sq-yd)	1.196
Square Kilometers (sq-km)	to	Square Miles (sq-miles)	0.3861
Volume Calculations			
Cubic Inches (cu-in)	to	Cubic Centimeters (cu-cm)	16.387
Cubic Inches (cu-in)	to	Liters (L)	0.01639
Quarts (qt)	to	Liters (L)	0.9464
Gallons (gal)	to	Liters (L)	3.7854
Cubic Yards (cu-yd)	to	Cubic Meters (cu-m)	0.7646
Cubic Centimeters (cu-cm)	to	Cubic Inches (cu-in)	0.06102
Liters (L)	to	Cubic Inches (cu-in)	61.024
Liters (L)	to	Quarts (qt)	1.0567
Liters (L)	to	Gallons (gal)	0.2642
Cubic Meters (cu-m)	to	Cubic Yards (cu-yd)	1.308



INTRODUCTION

Conversion Units			Multiply By:
Weight Calculations			
Ounces (oz)	to	Grams (g)	28.5714
Pounds (lb)	to	Kilograms (kg)	0.4536
Pounds (lb)	to	Short Tons (US tons)	0.0005
Pounds (lb)	to	Metric Tons (t)	0.00045
Short Tons (US tons)	to	Pounds (lb)	2000
Short Tons (US tons)	to	Kilograms (kg)	907.18486
Short Tons (US tons)	to	Metric Tons (t)	0.90718
Grams (g)	to	Ounces (oz)	0.035
Kilograms (kg)	to	Pounds (lb)	2.205
Kilograms (kg)	to	Short Tons (US tons)	0.001102
Kilograms (kg)	to	Metric Tons (t)	0.001
Metric Tons (t)	to	Pounds (lb)	2205
Metric Tons (t)	to	Short Tons (US tons)	1.1023
Metric Tons (t)	to	Kilograms (kg)	1000
Force Calculations			
Ounces Force (ozf)	to	Newtons (N)	0.2780
Pounds Force (lbf)	to	Newtons (N)	4.448
Pounds Force (lbf)	to	Kilograms Force (kgf)	0.456
Kilograms Force (kgf)	to	Pounds Force (lbf)	2.2046
Kilograms Force (kgf)	to	Newtons (N)	9.807
Newtons (N)	to	Kilograms Force (kgf)	0.10196
Newtons (N)	to	Ounces Force (ozf)	3.597
Newtons (N)	to	Pounds Force (lbf)	0.2248
Torque Calculations			
Pound Inches (lb-in)	to	Newton Meters (N-m)	0.11298
Pound Feet (lb-ft)	to	Newton Meters (N-m)	1.3558
Pound Feet (lb-ft)	to	Kilograms Force per Meter (kgfm)	0.13825
Newton Meters (N-m)	to	Pound Inches (lb-in)	8.851
Newton Meters (N-m)	to	Pound Feet (lb-ft)	0.7376
Newton Meters (N-m)	to	Kilograms Force per Meter (kgfm)	0.10197
Kilograms Force per Meter (kgfm)	to	Pound Feet (lb-ft)	7.233
Kilograms Force per Meter (kgfm)	to	Newton Meters (N-m)	9.807
Radiator Specific Heat Dissipation Calculations			
British Thermal Unit per Hour (BTU/hr)	to	Kilowatt per Degree Celsius (kW/°C)	0.000293
Kilowatt per Degree Celsius (kW/°C)	to	British Thermal Unit per Hour (BTU/hr)	3414.43
Temperature Calculations			
Degrees Fahrenheit (°F)	to	Degrees Celsius (°C)	(°F-32) 0.556
Degrees Celsius (°C)	to	Degrees Fahrenheit (°F)	(1.8 x °C) + 32



INTRODUCTION

Conversion Units			Multiply By:
Pressure Calculations			
Atmospheres (atm)	to	Bars (bar)	1.01325
Atmospheres (atm)	to	Kilopascals (kPa)	101.325
Bars (bar)	to	Atmospheres (atm)	0.98692
Bars (bar)	to	Kilopascals (kPa)	100
Bar (bar)	to	Pounds per Square Inch (psi)	14.5037
Inches of Mercury (in Hg)	to	Kilopascals (kPa)	3.377
Inches of Water (in H ₂ O)	to	Kilopascals (kPa)	0.2491
Pounds per Square Inch (psi)	to	Kilopascals (kPa)	6.895
Pounds per Square Inch (psi)	to	Bar (bar)	0.06895
Kilopascals (kPa)	to	Atmospheres (atm)	0.00987
Kilopascals (kPa)	to	Inches of Mercury (in Hg)	0.29612
Kilopascals (kPa)	to	Inches of Water (in H ₂ O)	4.01445
Kilopascals (kPa)	to	Pounds per Square Inch (psi)	0.145
Power Calculations			
Horsepower (hp)	to	Kilowatts (kW)	0.74627
Kilowatts (kW)	to	Horsepower (hp)	1.34
Fuel Performance Calculations			
Miles per Gallon (mile/gal)	to	Kilometers per Liter (km/L)	0.4251
Kilometers per Liter (km/L)	to	Miles per Gallon (mile/gal)	2.352
Velocity Calculations			
Miles per Hour (mile/hr)	to	Kilometers per Hour (km/hr)	1.609
Kilometers per Hour (km/hr)	to	Miles per Hour (mile/hr)	0.6214
Volume Flow Calculations			
Cubic Feet per Minute (cu-ft/min)	to	Liters per Minute (L/min)	28.32
Liters per Minute (L/min)	to	Cubic Feet per Minute (cu-ft/min)	0.03531



VISUAL IDENTIFICATION

VISUAL IDENTIFICATION



VISUAL IDENTIFICATION

TRANSMISSION IDENTIFICATION

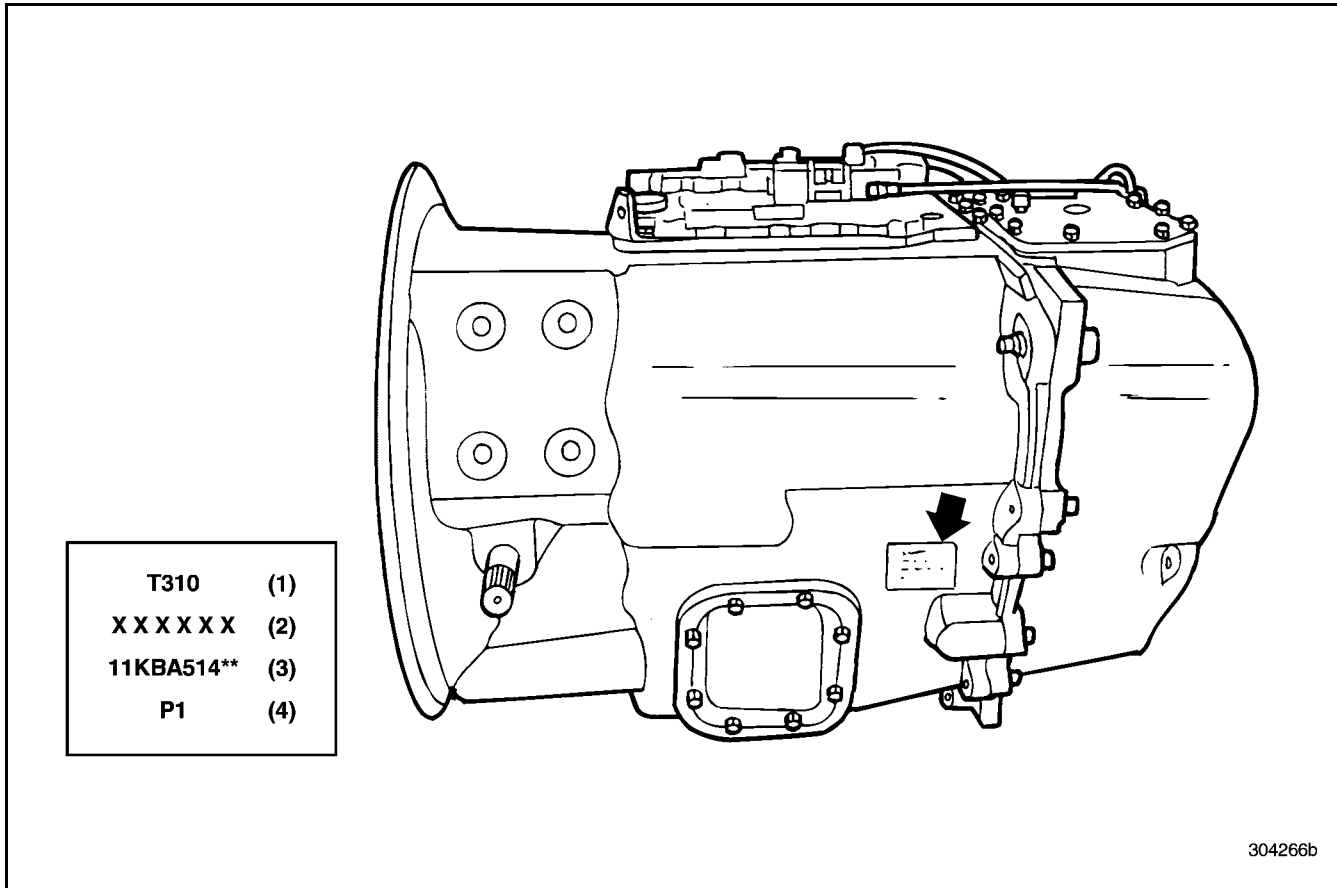

Figure 1 — Location of Identification Stamping on Left Side of Main Case

Unit Identification Stamping Location

The following model code information is stamped on the left side of the transmission, toward the rear of the main case. Refer to Figure 1.

1. Unit Symbol Identification
 - T = transmission
 - 3 = 300 series
 - 10 = useable forward speeds
2. Transmission Serial No.
3. Transmission Assembly (Part) No.
 - * = digits may vary
4. Specific variant of the base assembly number (variant to item No. 3)



VISUAL IDENTIFICATION

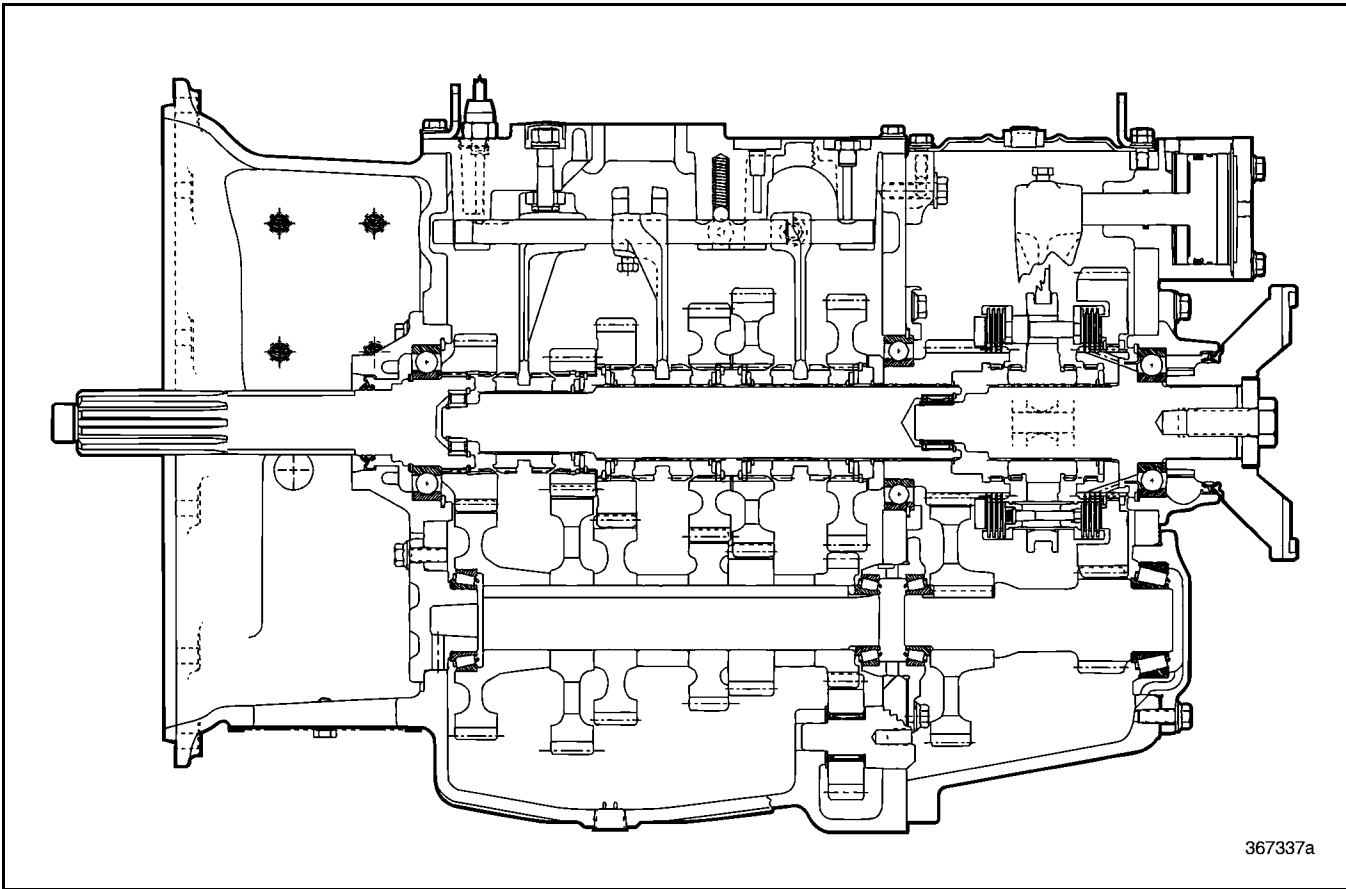

Figure 2 — Cutaway View of T310 Transmission



NOTES



DESCRIPTION AND OPERATION

DESCRIPTION AND OPERATION



DESCRIPTION AND OPERATION

DESCRIPTION AND OPERATION

T310 Transmissions

DESCRIPTION

The T310 transmission is a member of a new family of MACK transmissions designated as MAXITORQUE® ES (T300) Series transmissions. These transmissions are the next evolution of the durable triple-countershaft transmission. New features and product enhancements have been engineered into these transmissions to provide a wide range of advantages which include the following:

- New and revised gear ratios for greater overall range and versatility
- Lower "LOs" in forward and reverse for superior site maneuvering
- Improved shift quality through the use of a new sliding clutch with a fine-pitch tooth design versus the coarse-pitch tooth design of previous transmissions
- Enhanced durability
- Weight reduction versus the previous series transmissions

The T310 transmissions are triple-countershaft units. They consist of a compact main box which houses five non-synchronized forward-speed gear sets plus a reverse gear set. The rear case of the T310 transmission is also a triple-countershaft unit. The rear case consists of Lo-range and Hi-range gear sets which are air controlled by an air shift selector located on the main shift lever.

The main case and the bell housing are a one-piece casting, made from aluminum and heat-treated for strength.

The main case also has 6- and 8-bolt openings that allow for the addition of Power Take-Off (PTO) units. PTO operation is off the (53 tooth) countershaft fifth (10th) speed gear.

The bearings are housed in cast-iron bearing retainers (covers). Tapered roller bearings are used at each end of all transmission countershafts.

All gears are of the spur-type design and are in constant mesh with mating gears. All shifting is done by forks and sliding clutches. The shift rails and forks are integral with the shift cover for the main case.

A single gear shift lever is used to shift through a standard "H" pattern. An air shift range selector, mounted on the gear shift lever, is also used for shifting the T310. The range selector directs air pressure to the compound air shift cylinder. Operating the selector causes a shift between Hi range or Lo range in the compound.

The T310 has 10 forward speeds and two reverse speeds. Each of the five forward speeds in the main case is used once with the compound in Lo range (first, second, third, fourth and fifth), and once more with the compound in Hi range (sixth, seventh, eighth, ninth and tenth). Reverse may be used in either Lo range or Hi range. See Figure 7.

The compound range shift is accomplished using a plate-type synchronizer, shifted by a range shift cylinder and a shift fork.

The six countershafts, three in the main case and three in the rear case, are equally spaced around the mainshafts. This design distributes the load equally among the countershafts, thus keeping normal deflection and gear tooth loading to a minimum.

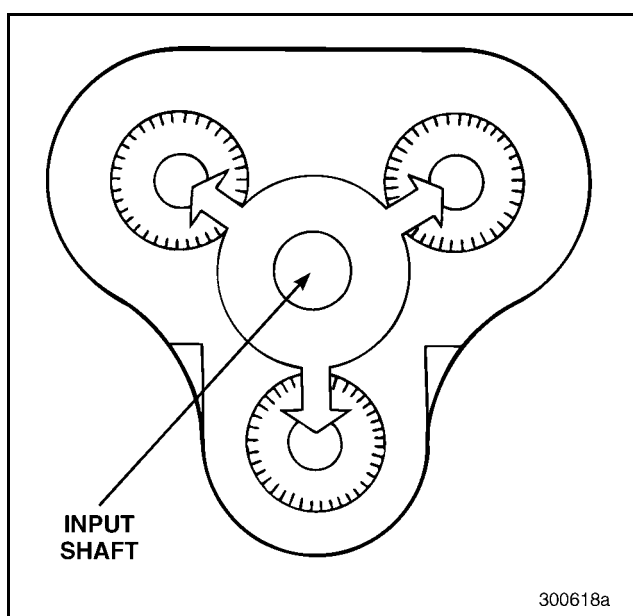

Figure 3 — Equal Torque Distribution



DESCRIPTION AND OPERATION

Lubrication

SPLASH LUBRICATION

All parts inside the transmission are lubricated by a splash-and-gravity system. To minimize churning, only the lower countershaft dips into the lubrication oil. As the gears on that countershaft spin, a constant spray of oil is directed to all internal parts of the transmission. The oil cools as it circulates over the aluminum case. Troughs and passages, cast into the inside of the case, capture and direct oil to the bearings.

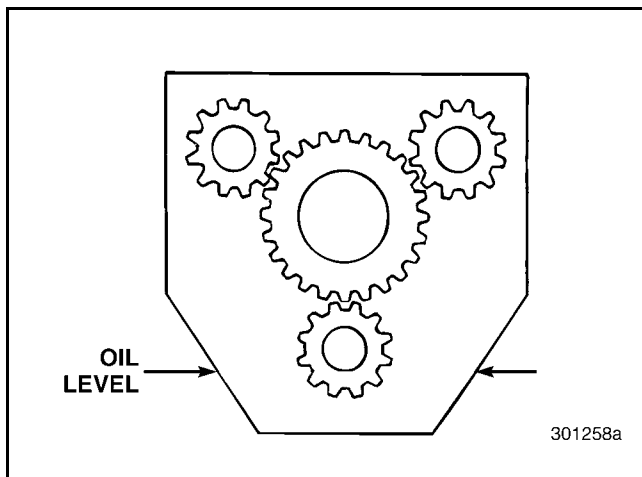

Figure 4 — Splash Lubrication

TRANSMISSION CASE OIL COOLER LINE PLUGS

An integral oil cooler pump system has been developed for MACK T300 series transmissions. The oil cooler is **optional** for engine ratings under 400 hp and chassis ratings under 80,000 GVW. The oil cooler system is **required** when the engine rating is equal to or exceeds 400 hp, or the chassis rating is greater than 80,000 GVW.

On T310 transmissions that are not built with oil cooler pump systems, the tube line openings are plugged or capped. The main suction tube area contains a metal plug and the outlet fitting area receives a plastic cap.

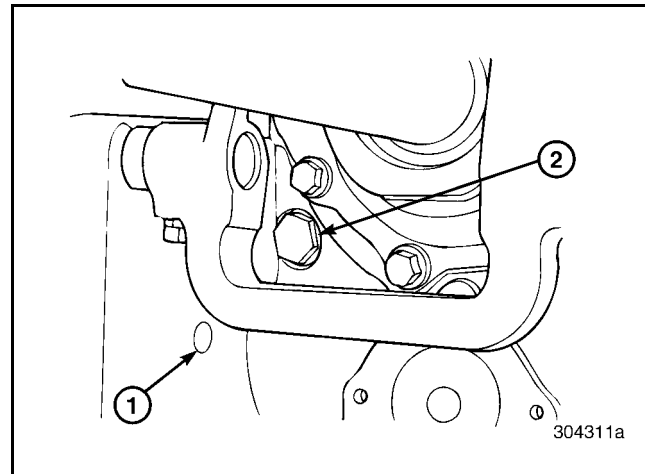

Figure 5 — Transmission Case Oil Cooler Line Plugs

- | | |
|-----------------------|----------------------|
| 1. Outlet Plastic Cap | 2. Suction Tube Plug |
|-----------------------|----------------------|

MAGNETIC OIL FILTER

A magnetic oil filter assembly is built into the right side of the main case. It consists of a magnetic plug which removes ferrous metallic particles from the passing oil. After passing the magnetic plug, the oil is channelled upward to an outlet, where it returns (by gravity) down into the transmission case sump. The magnetic plug is removable from the outside of the transmission, without the necessity of draining the oil since this plug is above the oil level. The drain plug at the bottom of the case is also magnetic.

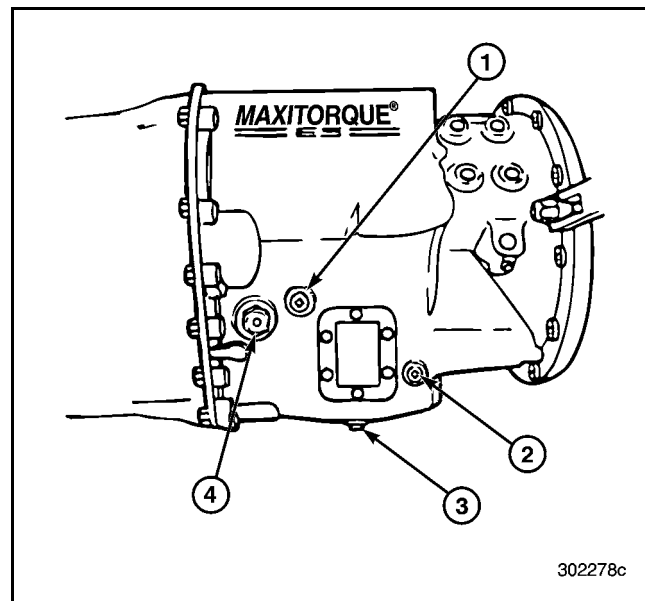

Figure 6 — Plug Locations

- | | |
|---------------------------|----------------------------|
| 1. Magnetic Filter Plug | 3. Oil Drain Plug |
| 2. Oil Temperature Sensor | 4. Oil Fill and Level Plug |



DESCRIPTION AND OPERATION

Gear Ratios and Shift Pattern

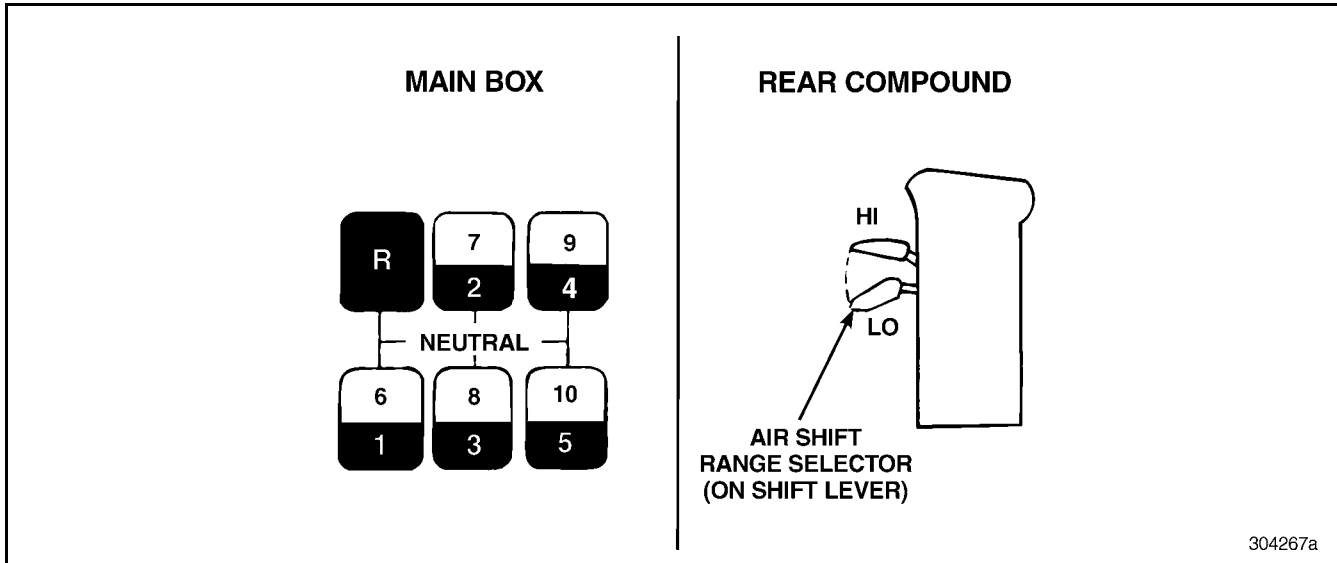

Figure 7 — T310 Gear Ratios and Shift Pattern

Gear Position (Main Box)	Lo-Range Ratios	Hi-Range Ratios
1/6	13.81	2.67
2/7	10.05	1.94
3/8	7.18	1.39
4/9	5.17	1.00
5/10	3.75	0.73
R/R	14.73	2.75



DESCRIPTION AND OPERATION

T310 Shifting Instructions

CAUTION

Make sure air pressure is at least 100 psi and unit is warmed before making range shifts. Always start in Lo range. This also applies to dynamometer testing. When the truck is stationary, do NOT shift into Hi range and then start moving the truck. Otherwise, damage to the synchronizer may result. To avoid transmission damage, do not change range while in reverse.

The T310 unit is a range-shifted transmission which has 10 forward "highway" speeds. This transmission features a Lo and Hi auxiliary compound section controlled by an air shift range selector located on the shift lever. The compound section is equipped with a synchronizer to facilitate Lo-/Hi-range shifting.

The Lo range provides five low ratios. Never attempt to move the vehicle from a stopped position in any gear higher than fifth speed gear. Depending on load, grade, or road conditions, it may be necessary to start in first, second, third or fourth speed gears. In Hi range there are five forward gears that can be shifted in the standard manner. Always remember, however, to double clutch whether moving up or down through these gears. Reverse gear can be used in Lo range or Hi range.

UPSHIFTING (NORMAL HIGHWAY)

With the shift lever in neutral, flip the air shift range selector down to Lo range. Then shift the transmission into first gear. Shift up to second, third, fourth and fifth speed gears, double clutching between the gears. When maximum engine RPM has been reached in fifth gear, flip the air shift range selector up to Hi range (preselect). Then move the shift lever through neutral to sixth gear. As the shift lever passes through neutral, the transmission is placed into Hi range. Continue following the normal sequence (7-8-9-10), being sure to double clutch from one gear to the next.

DOWNSHIFTING (NORMAL HIGHWAY)

Shift from 10th speed gear down through the Hi range (9-8-7-6), double clutching through each gear. While still in sixth speed gear, flip the air shift range selector down to Lo range (preselect). Then move the shift lever through neutral to fifth speed gear. As the shift lever passes through neutral, the transmission is placed into Lo range. Then, shift down to fourth, third, second and first speed gears, double clutching between all gears.

CAUTION

- *Always start in Lo range according to shift marker plate instructions. Never start in a gear higher than fifth speed gear, even when dynamometer testing.*
- *When the truck is stationary, do not shift into Hi range and then start moving the truck. Damage to the synchronizer can result.*
- *Be careful not to overspeed the engine during downshifting. Damage to powertrain components may result.*
- *To avoid transmission damage, do not change range while moving in reverse gear.*

Power Flow Diagrams

The following illustrations show power flow through the T310 transmission in each gear range.

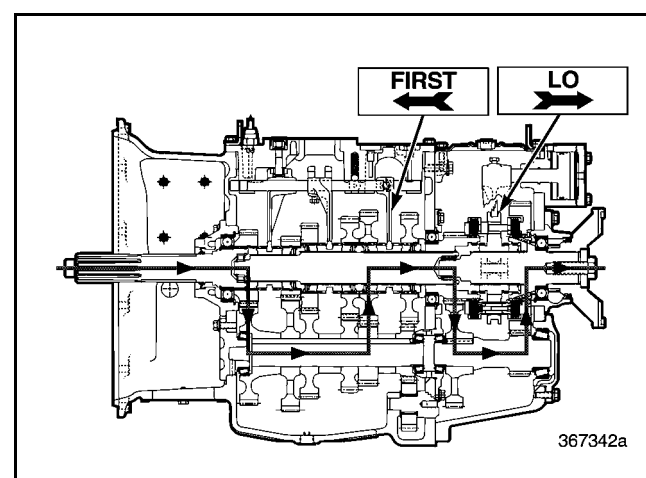

Figure 8 — First Speed



DESCRIPTION AND OPERATION

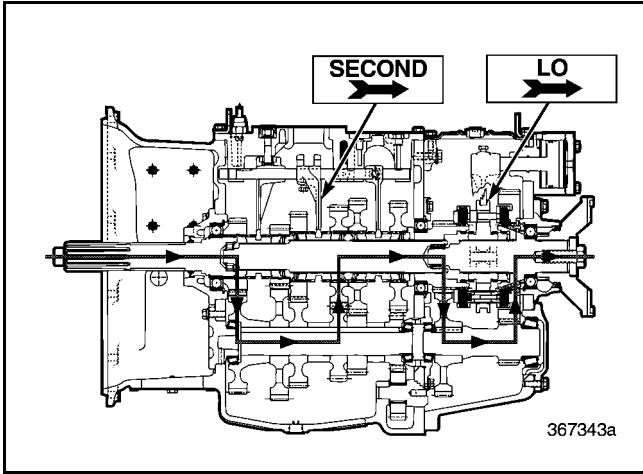

Figure 9 — Second Speed

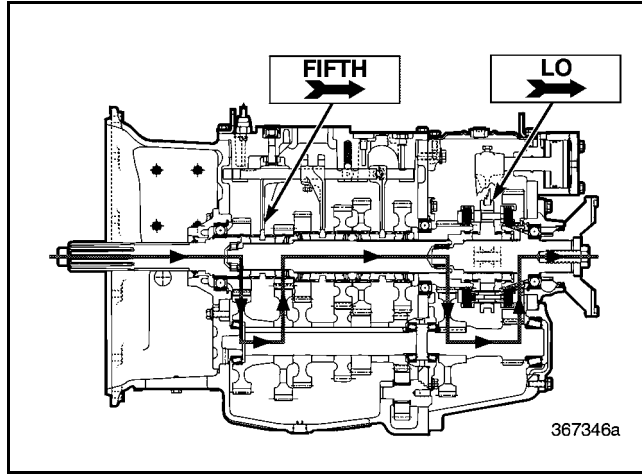

Figure 12 — Fifth Speed

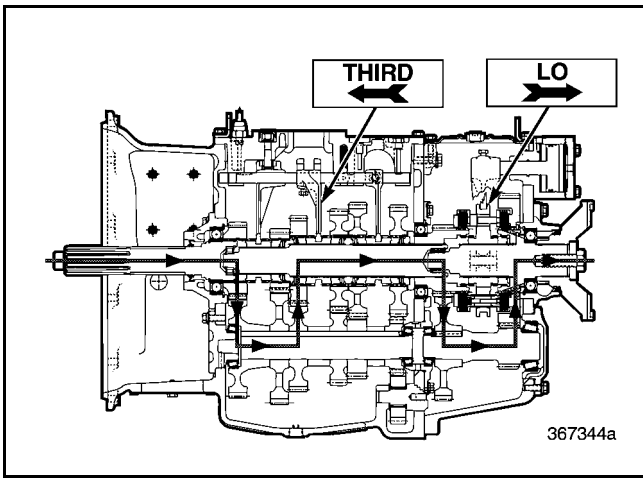

Figure 10 — Third Speed

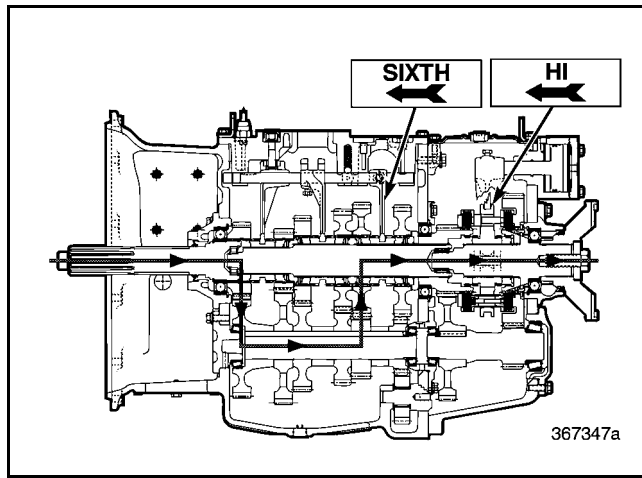

Figure 13 — Sixth Speed

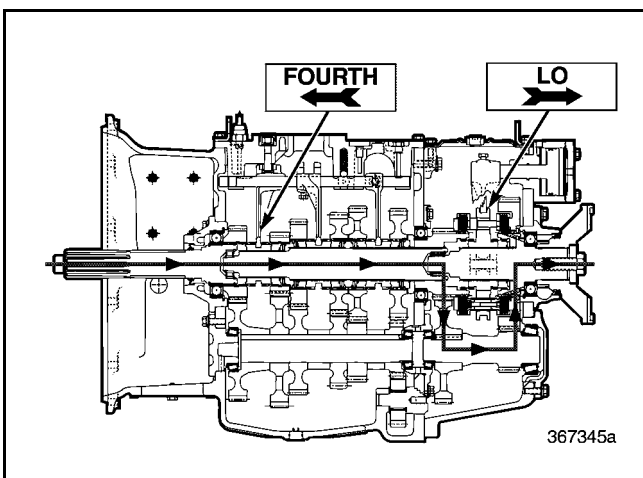

Figure 11 — Fourth Speed

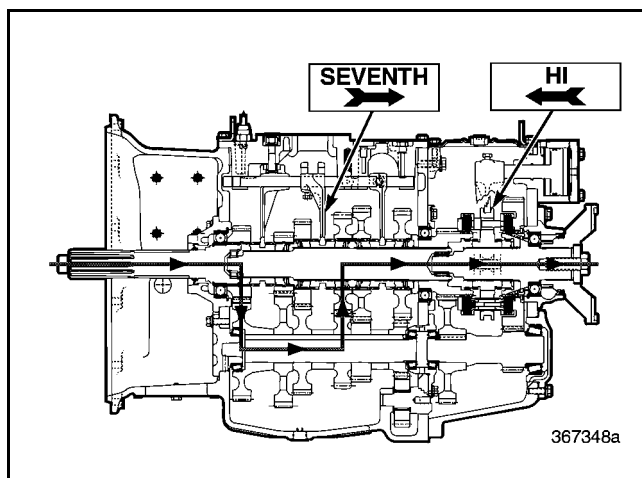

Figure 14 — Seventh Speed



DESCRIPTION AND OPERATION

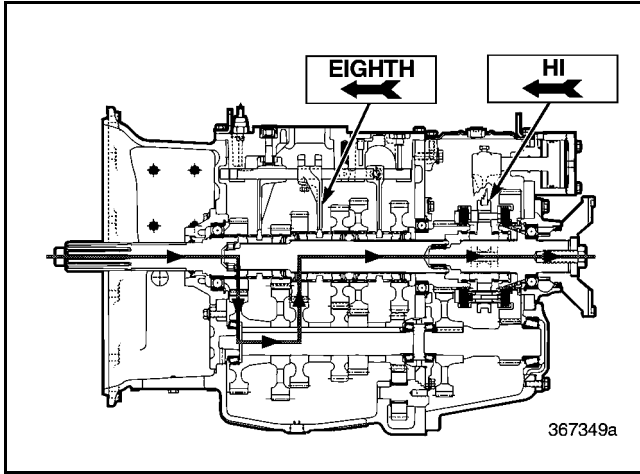

Figure 15 — Eighth Speed

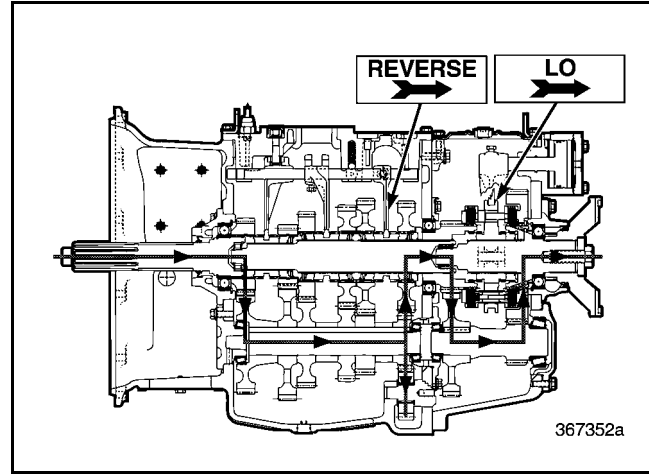

Figure 18 — Reverse Speed (Lo)

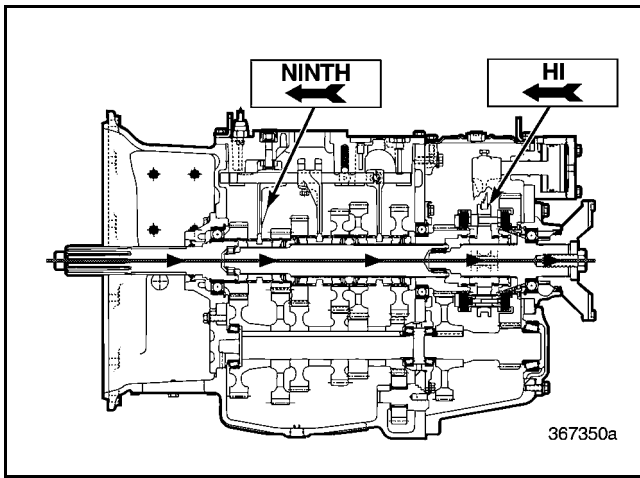

Figure 16 — Ninth Speed

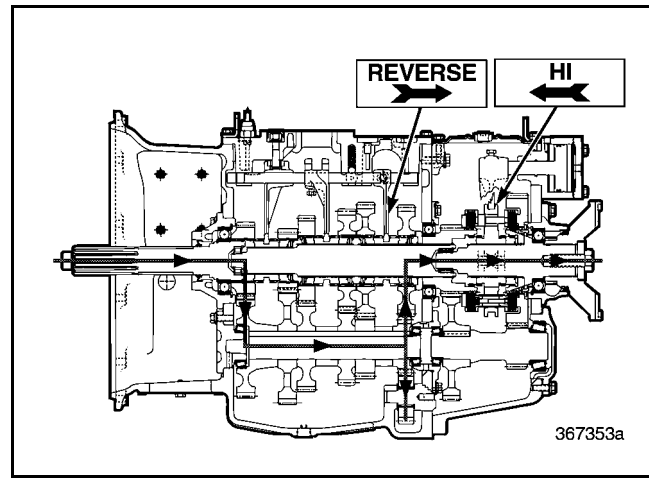

Figure 19 — Reverse Speed (Hi)

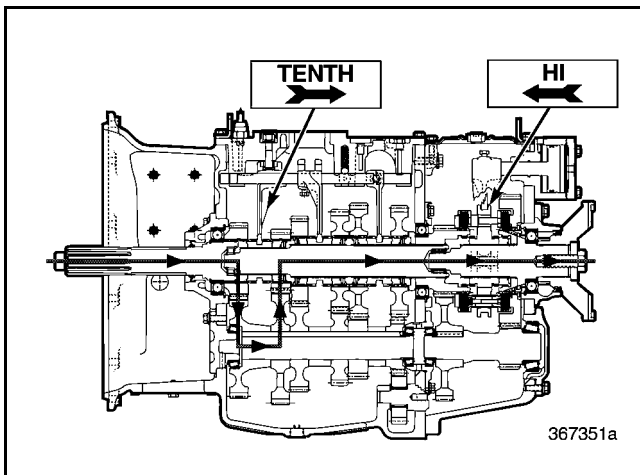

Figure 17 — Tenth Speed



NOTES



COMPONENT LOCATOR

COMPONENT LOCATOR



COMPONENT LOCATOR

COMPONENT LOCATOR

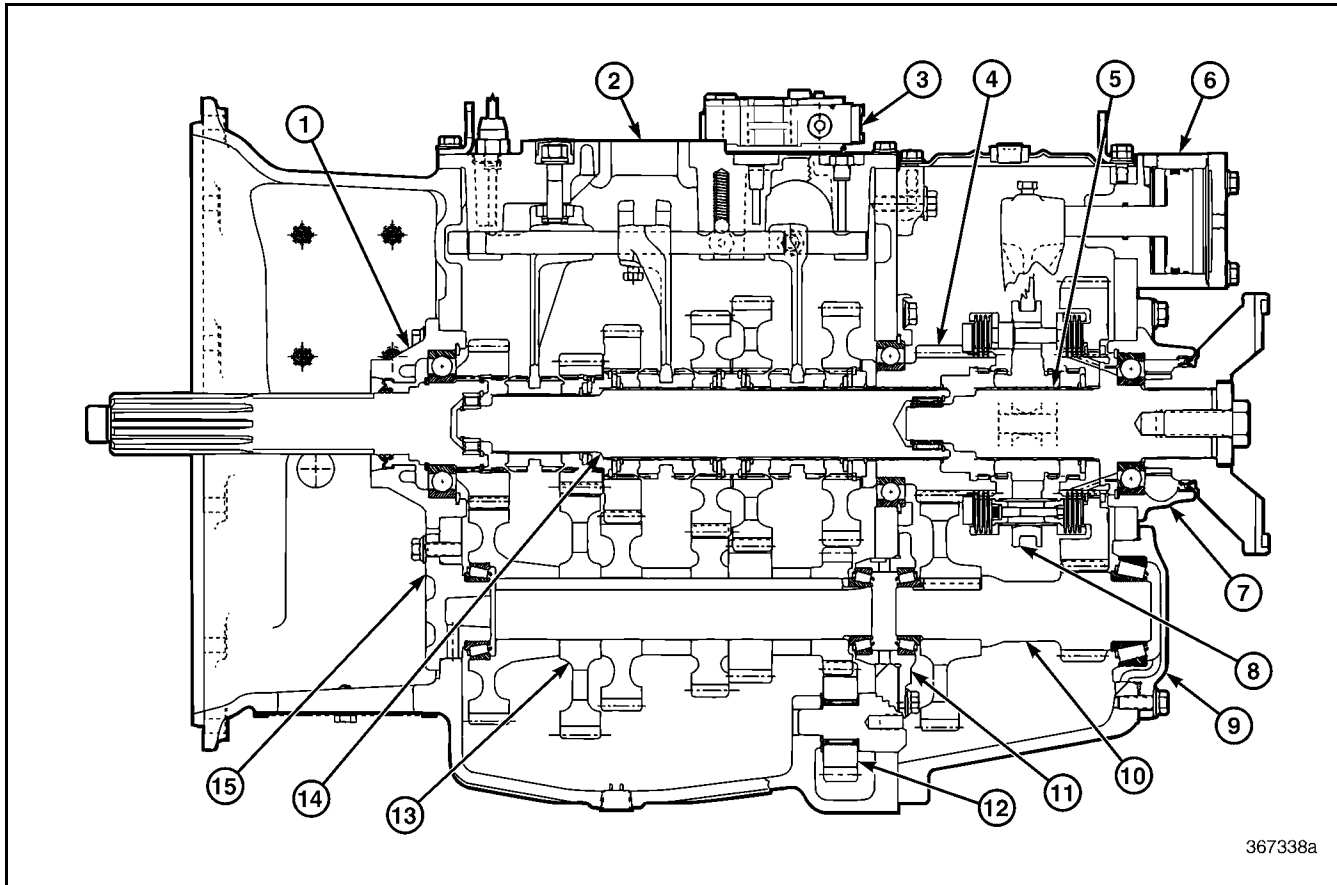

367338a

Figure 20 — Major Component Locations for T310 Transmission

1. Main Drive Pinion Assembly	7. Rear Mainshaft Bearing Cover	12. Reverse Idler Gear
2. Main Case Shift Cover Assembly	8. Synchronizer Assembly	13. Front Countershaft Assembly
3. Range Shift Valve Assembly	9. Rear Countershaft Bearing Cover	14. Front Mainshaft Assembly
4. Compound Main Drive Gear	10. Rear Countershaft Assembly	15. Front Countershaft Front Bearing Cover
5. Rear Mainshaft and Synchronizer Assembly	11. Front Countershaft Rear Bearing Cover	
6. Range Shift Cylinder		



TROUBLESHOOTING

TROUBLESHOOTING



TROUBLESHOOTING

TROUBLESHOOTING CHARTS

NOISY TRANSMISSION

Probable Cause	Remedy
a. Low oil level	a. Fill to correct level.
b. Wrong oil used	b. Drain and refill with correct oil.
c. Side-mounted PTO installed too tight or too loose	c. Reinstall PTO correctly.
d. Loose bell housing-to-flywheel housing capscrews	d. Install new capscrews, using Loctite®.
e. Incorrect clutch-driven discs used	e. Install correct clutch-driven discs.
f. Gears worn, chipped, rough, cracked	f. Replace gears.
g. Bearings worn, cracked, corroded, galled, etc.	g. Replace bearings.
h. Mismatched carrier ratios	h. Install correct matched gearing.
i. Resonating (ringing) driveshaft	i. Install suitable dampening material, then high-speed balance driveshaft.
j. Driveline angles (air bags deflated)	j. Correct driveline angles (allow air bags to fill).

HARD SHIFTING

Probable Cause	Remedy
a. Incorrect driving practices	a. Train driver in correct driving practices.
b. Low oil level	b. Fill to correct level.
c. Improperly adjusted clutch, clutch linkage, clutch brake or shift linkage	c. Adjust properly.
d. Wrong oil used	d. Drain and refill with correct oil.
e. Remote shift linkage not lubricated	e. Clean and lubricate.
f. Shift lever binding or has interference	f. Relieve binding or interference.
g. Poppet balls binding in their holes	g. Clean holes and balls.
h. Loose setscrews in shifters or shift forks	h. Tighten to correct torque.
i. Worn spigot bearing	i. Replace bearing.
j. Clutch brake ears broken	j. Replace clutch brake.
k. Clutch discs worn into main drive pinion	k. Replace clutch discs and main drive pinion.
l. Mainshaft snap ring or thrust washer failure	l. Replace snap rings or thrust washers.
m. Improperly adjusted fourth/fifth eccentric pin	m. Adjust properly.
n. PTO engaged	n. Disengage PTO.



TROUBLESHOOTING

GEAR DISENGAGEMENT (JUMPING OUT OF GEAR)

Probable Cause	Remedy
a. Excessive length and/or weight of gear shift lever and/or knob	a. Replace with standard lever and/or knob.
b. Shift lever interference	b. Remove interference.
c. Improperly adjusted remote control linkage	c. Adjust properly.
d. Worn or loose mounting insulators	d. Replace insulators.
e. Loose, broken or missing capscrews between clutch housing and flywheel housing	e. Replace capscrews, check threads in case.
f. Weak or broken shift rail poppet springs	f. Replace springs.
g. Bent or worn shift forks	g. Replace forks.
h. Broken snap rings	h. Replace snap rings.
i. Shift rail bent or poppet notches worn	i. Replace shift rail.
j. Worn taper or chipped teeth on sliding clutch teeth	j. Replace sliding clutch and mating gear if clutch teeth are damaged.
k. Worn or damaged spigot bearing	k. Replace bearing.
l. Engine flywheel housing misalignment	l. Realign properly.
m. Chassis resonant ride	m. Correct resonance.

OIL LEAKS

Probable Cause	Remedy
a. Oil level too high	a. Drain to correct level.
b. Fill plug loose or O-ring defective or missing	b. Tighten plug or correct O-ring condition.
c. Drain plug or magnetic plug loose	c. Tighten plug.
d. Loose or missing capscrews	d. Tighten or replace.
e. Improper lubricant used	e. Drain and refill with correct oil.
f. Clogged breather	f. Clean or replace.
g. Gaskets or O-rings broken, shifted or squeezed out of position	g. Replace gaskets or O-rings.
h. Worn oil seals	h. Replace seals.
i. O-rings or seals in air shift cylinder leaking air pressure into transmission	i. Replace O-rings or seals.

BEARING FAILURE

Probable Cause	Remedy
a. Dirt in system	a. Clean system, replace bearings as needed, flush and refill with clean oil.
b. Wrong grade of oil or contaminated oil	b. Clean system, replace bearings as needed, flush and refill with clean oil.
c. Excessive vibrations	c. Eliminate vibrations, replace bearings.
d. Binding or seized propeller shaft slip yoke	d. Clean and replace as needed.
e. Improper bearing clamping	e. Replace bearings and reclamp using correct procedures.
f. Improper bearing installation (preloads, etc.)	f. Replace using correct procedures.



TROUBLESHOOTING

AIR SHIFT MALFUNCTIONS

Probable Cause	Remedy
a. Low system air pressure	a. Wait for pressure to build back up to normal.
b. Restricted or clogged air filter in range shift valve	b. Replace air filter.
c. Restricted air line (bent, squeezed, twisted, etc.)	c. Re-route and/or replace air lines
d. Air lines too small	d. Replace with correct size air lines.
e. Defective O-rings in air shift cylinder	e. Replace O-rings.
f. Scored air shift cylinder or piston	f. Repair or replace cylinder or piston.
g. Defective range shift valve and/or air shift selector valve (on shift lever)	g. Repair or replace cylinder or piston.
h. Defective synchronizer	h. Repair or replace as needed.
i. Incorrect driving practices (not preselecting)	i. Train driver in correct driving practices.
j. Range synchronizer friction discs worn or burned	j. Replace synchronizer discs as needed.
k. Intermixed synchronizer parts	k. Install matched parts.



MAINTENANCE

MAINTENANCE



MAINTENANCE

TRANSMISSION MAINTENANCE

Checking Oil Level

NOTE

Perform oil level check when the oil is at operating temperature. The vehicle must be in a level position, both front-to-rear and side-to-side.

- Check the transmission oil level at the intervals specified in the Maintenance and Lubrication Manual (TS494).
- To check the oil level in the transmission, first remove the filler plug (2) from the right side of the main case.

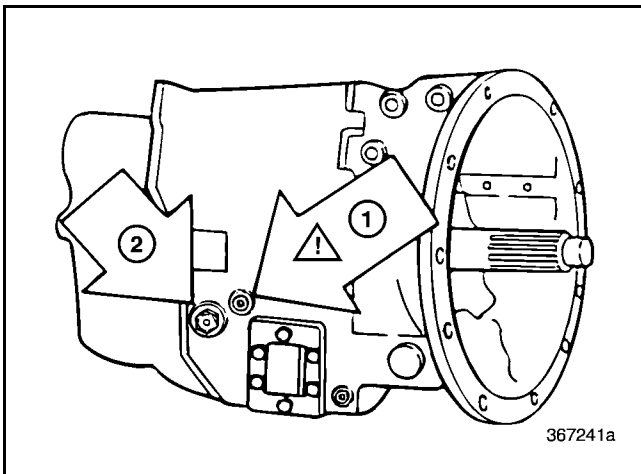

Figure 21 — Oil Filler and Check Plug

- | | |
|---|--|
| 1. Magnetic Filter Plug (Not for Level Check) | 2. Oil Filler and Check Plug for Level Check |
|---|--|

- The oil must be level with the bottom of the filler plug hole as determined by feel or by visual inspection.

WARNING

Be careful not to burn your finger in hot gear oil when checking the oil level in the transmission.

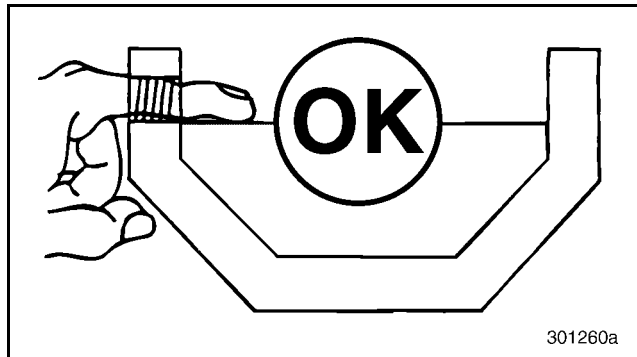

Figure 22 — Correct Oil Level

- If oil can only be felt by reaching the finger down into the unit, the oil level is too low.

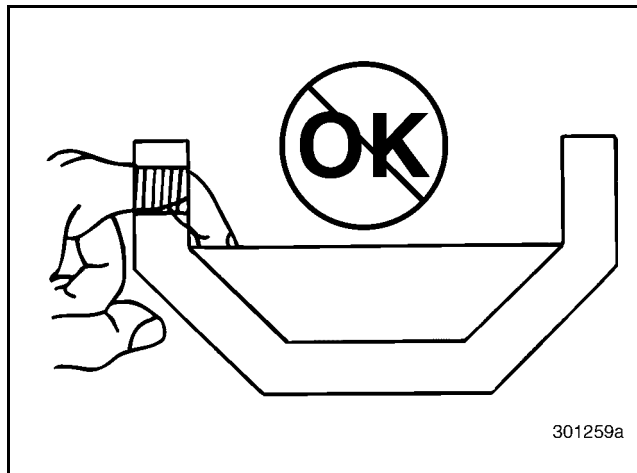

Figure 23 — Incorrect Oil Level

- Add specified make-up oil, if needed, until the oil is level with the bottom of the filler plug hole. Do NOT overfill. Use oil of the proper specification. MACK-approved gear oils can be found on the internet at www.macktrucks.com.
- Reinstall and tighten the oil filler plug (Figure 21) as follows:
 1. Check that the O-ring on the plug is not cut or damaged. Replace as necessary.
 2. Install the plug and tighten to 35–50 lb-ft (47–68 N•m) torque.



MAINTENANCE

Changing Oil

CAUTION

Preserve the environment! Drained gear oil is classified as a hazardous toxic material which must be recovered, handled, stored and disposed of according to applicable State or Federal guidelines.

Change Interval

- Change the oil at intervals specified in the Maintenance and Lubrication Manual (TS494).

Draining Oil

- Before draining oil from the transmission, the oil should be at normal operating temperature.
- Remove the magnetic drain plug from the bottom of the transmission main case and drain the hot oil into an industry-approved recovery container.
- Clean and replace the magnetic drain plug, then torque the plug to 25–30 lb-ft (34–41 N•m).

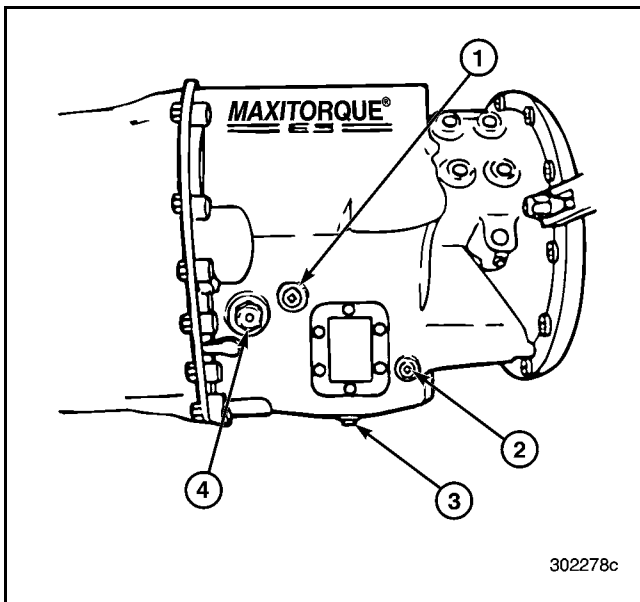

Figure 24 — Plug Locations

- | | |
|---------------------------|----------------------------|
| 1. Magnetic Filter Plug | 3. Oil Drain Plug |
| 2. Oil Temperature Sensor | 4. Oil Fill and Level Plug |

Oil Fill

- Remove the oil filler plug (2) (Figure 25), then fill the transmission using specified oil until the oil is level with the bottom of the filler plug hole (also see Figure 22). Do NOT overfill.

NOTE

MACK-approved lubricants can be found on the internet at www.macktrucks.com, then click on the Parts and Service category.

- Reinstall and tighten the oil filler plug as follows:
 - Check that the O-ring on the plug is not cut or damaged. Replace as necessary.
 - Install the plug and tighten to 35–50 lb-ft (47–68 N•m) torque.

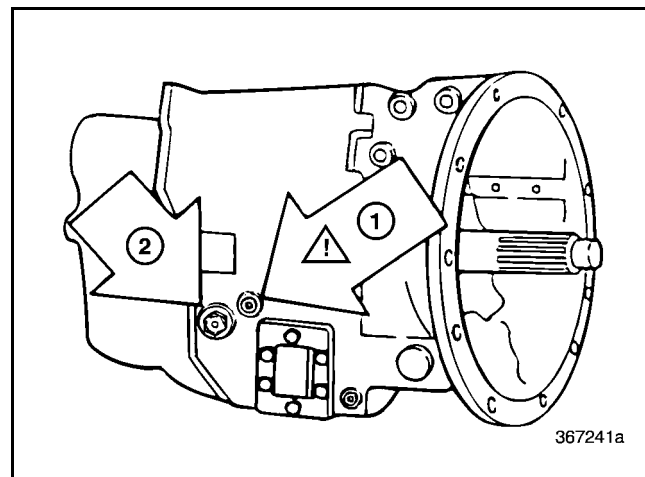

Figure 25 — Oil Filler and Check Plug

- | | |
|---|------------------------------|
| 1. Magnetic Filter Plug (Not for Level Check) | 2. Oil Filler and Level Plug |
|---|------------------------------|

CAUTION

Be sure to add oil to the transmission through the filler hole, NOT the magnetic filter plug hole. Damage to the transmission and seals can occur due to overfilling. The magnetic oil filter hole is higher on the transmission case than the filler hole.



MAINTENANCE

Magnetic Oil Filter Plug

Remove the magnetic oil filter plug and clean the magnet in the plug every time the oil is changed. Reinstall the magnetic plug. Tighten the plug to 20–23 lb-ft (27–31 N•m) torque.

Air Breather

The T310 has one air breather located on the main case shift cover. The air breather should be removed and cleaned with a suitable solvent every time the oil is changed. Also check to be sure that airflow through the breather is unobstructed. Reinstall breather into the main case shift cover and tighten until snug.



REPAIR INSTRUCTIONS

REPAIR INSTRUCTIONS



REPAIR INSTRUCTIONS

TRANSMISSION DISASSEMBLY PROCEDURES [320]

NOTE

Unless a complete overhaul is necessary, remove only those parts required to gain access to faulty parts. Do not disturb parts with a heavy press fit (interference fit) unless replacement is necessary. When replacement is necessary, use proper press setups and pullers to protect usable parts from damage.

NOTE

External inspection of the unit before cleaning and disassembly often reveals information about existing operating conditions. This may help when diagnosing problems.

SERVICE HINT

During disassembly, remember the sequence in which components and individual parts are removed from the transmission. It is good practice to keep related parts together in groups when removed. Small parts such as shims and spacers can be wired to the larger pieces with which they belong. Groups of parts can be kept together in boxes.

SERVICE HINT

Keep parts such as shim packs, bearing cones, bearing retainers (covers), bearing cups and gears with the original countershaft from which they are removed. Mark each countershaft and bearing cover before removal. Mark the upper left front and rear countershafts and bearing covers (viewed from rear) as number 1. Mark the upper right front and rear countershafts and bearing covers (viewed from rear) as number 2. Mark the lower front and rear countershafts and bearing covers as number 3.

1. Clean the transmission externally and mount it in an overhaul stand. Drain the lubricant and plug any air line openings to prevent dirt from entering.

NOTE

Lift and move the transmission with a hoist, using the two lifting brackets provided.

2. Disconnect the air lines attached to the range shift valve and the range shift cylinder. Air lines are installed using a push/pull type fitting and are best removed using tool kit 9032-1800trk which can be obtained through the MACK parts system. Disconnect the air lines using the following procedure:
 - a. Select the appropriate size release tool from kit 9032-1800trk.

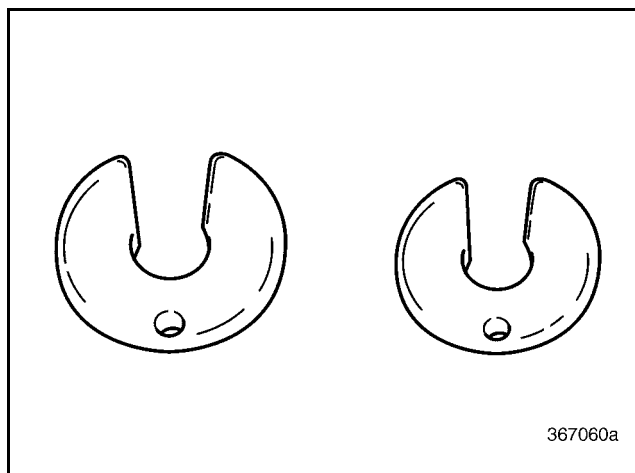

Figure 26 — Air Line Release Tools



REPAIR INSTRUCTIONS

- b. Insert the tool over the air line and release the lines from the fittings by pushing in toward the fitting and at the same time, pulling on the hose.

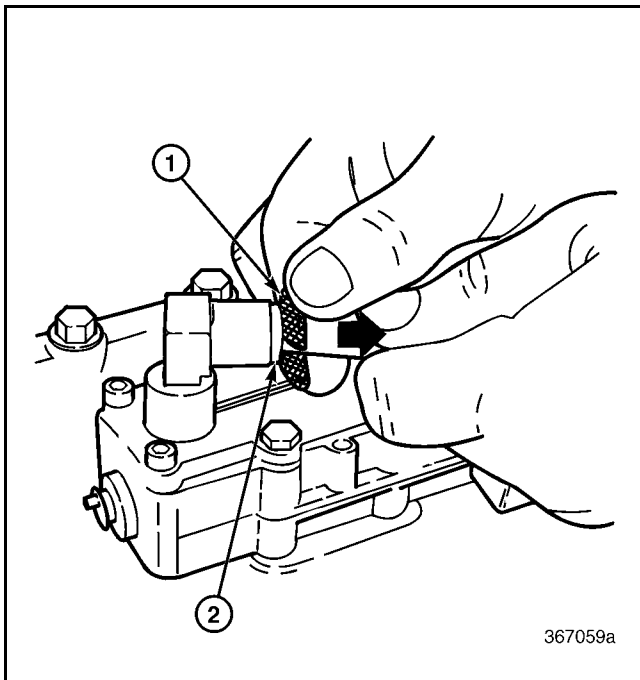

Figure 27 — Removing Air Lines

- | | |
|--|--|
| 1. Air Line Removal Tool
9032-1800trk | 2. Air Hose Fitting Release
Ferrule |
|--|--|

3. Label all disconnected air lines for proper reassembly.
4. Using the appropriate tools, remove the range shift valve 5/32 Allen-head screws (outer) and capscrews (inner).

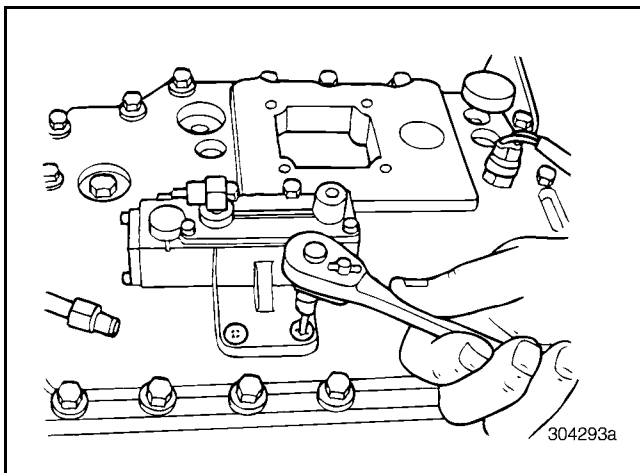

Figure 28 — Removing Range Shift Valve Allen-Head Screws

5. Remove the range shift valve, interlock sleeve, spring, pin and O-ring from the main case shift cover.

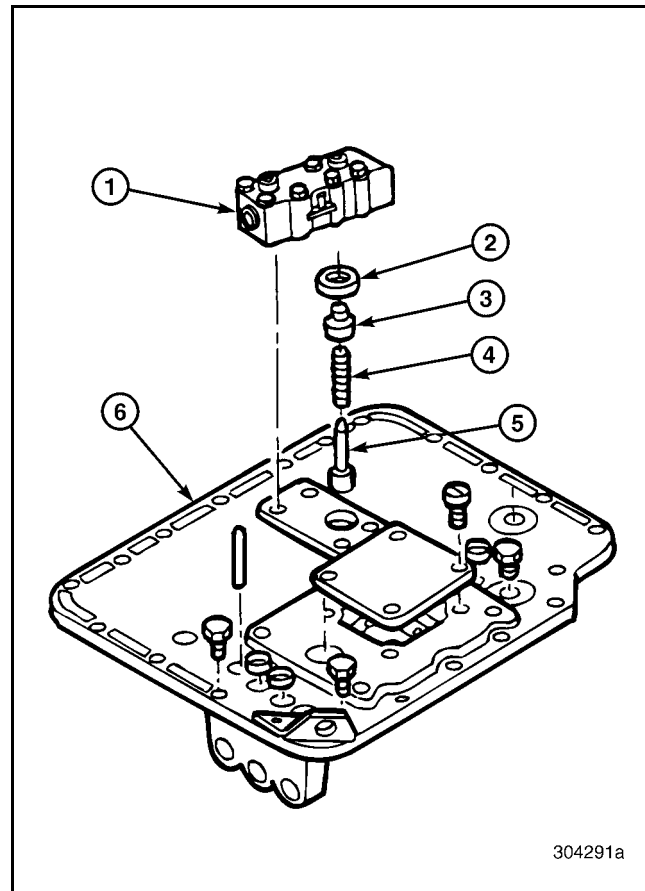

Figure 29 — Removing Range Shift Components

- | | |
|----------------------|---------------------|
| 1. Range Shift Valve | 4. Interlock Spring |
| 2. O-Ring | 5. Interlock Pin |
| 3. Interlock Sleeve | 6. Shift Cover |



REPAIR INSTRUCTIONS

6. Remove the clutch release bearing assembly, shafts, yoke and clutch brake (if equipped).
7. With transmission in neutral, remove the main case shift cover capscrews.

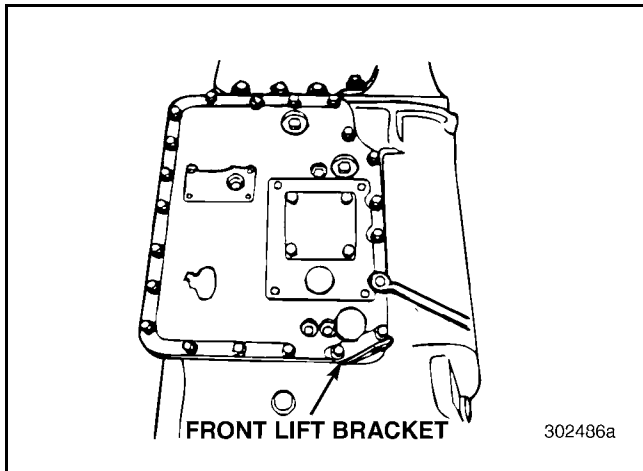

Figure 30 — Removing Main Case Shift Cover Capscrews

8. Remove the main case shift cover assembly and cover gasket.

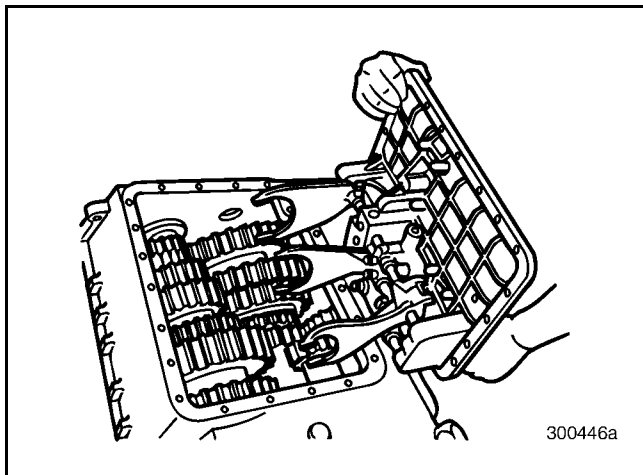

Figure 31 — Removing Main Case Shift Cover

9. Remove the rear case top cover capscrews.

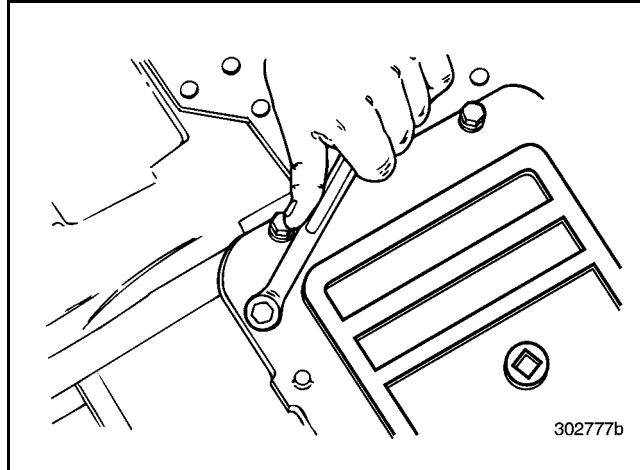

Figure 32 — Removing Rear Case Top Cover Capscrews

10. Remove the rear case top cover. Carefully scrape RTV sealant from around top cover opening.

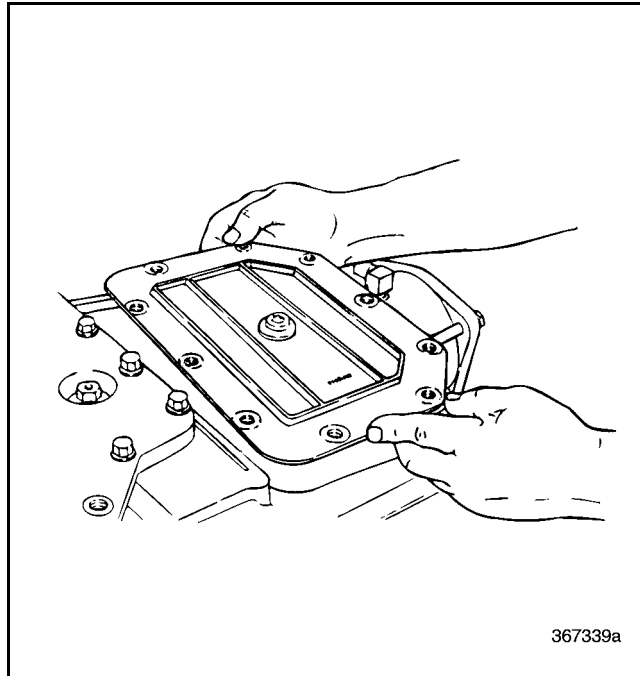

Figure 33 — Removing Rear Case Top Cover



REPAIR INSTRUCTIONS

SERVICE HINT

To remove the drive yoke bolt, place at least two gears in both the main case and the rear case into engagement. This will lock the transmission gearing and prevent it from rotating while removing the yoke bolt.

11. Reach through the rear case top opening and verify that the synchronizer assembly sliding clutch is engaged.
12. Reach into the main case top opening and move at least two sliding clutches into engagement. This locks two different gears to the mainshaft and prevents the gears and shaft of the transmission from rotating.
13. Remove the drive yoke or drive flange by separating the capscrew and clamp plate.

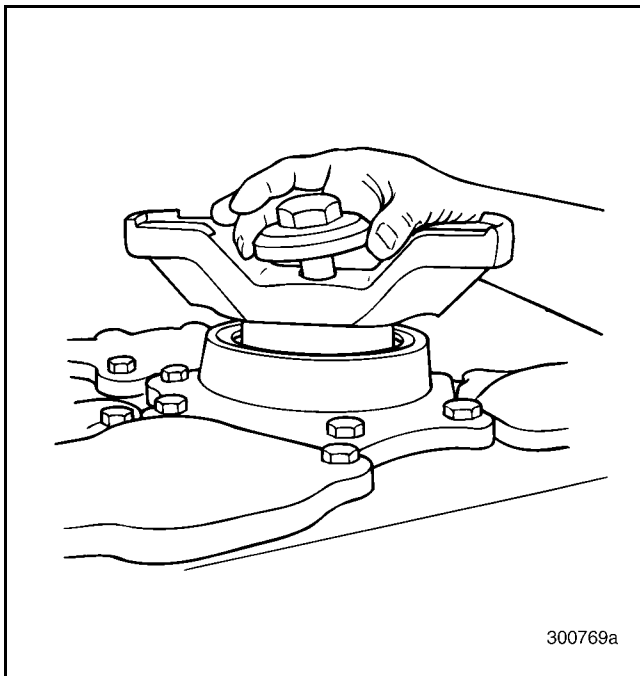

Figure 34 — Removing Clamp Plate and Capscrew

14. Remove the drive yoke, using a suitable puller such as J 07804-A or equivalent.

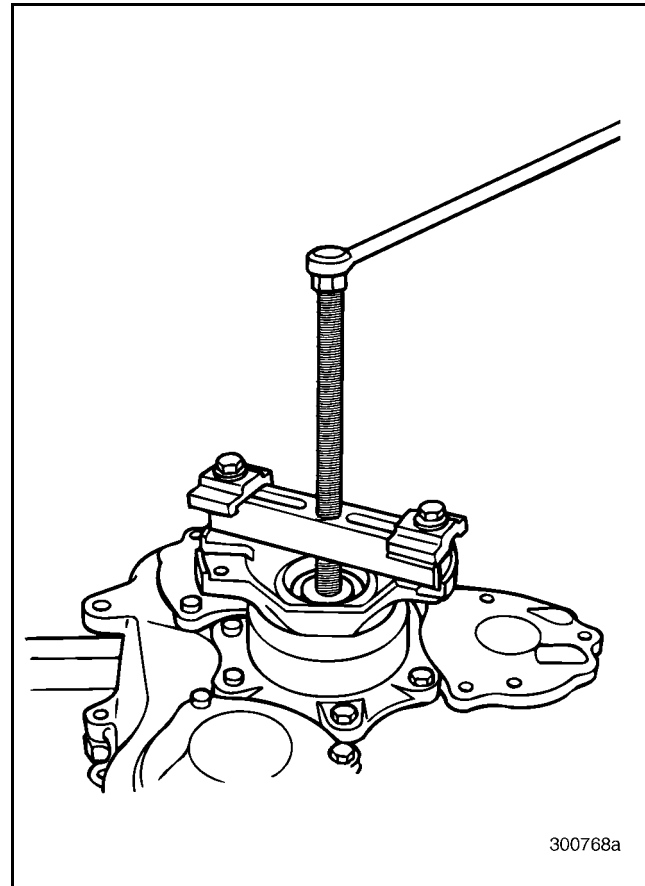

Figure 35 — Removing Drive Yoke

15. Shift the transmission gears into neutral. Verify that the transmission is in neutral.
16. If not already done, disconnect the air lines from the range shift cylinder. Label air lines for correct installation during assembly.



REPAIR INSTRUCTIONS

17. Remove the shift fork locking bolt.

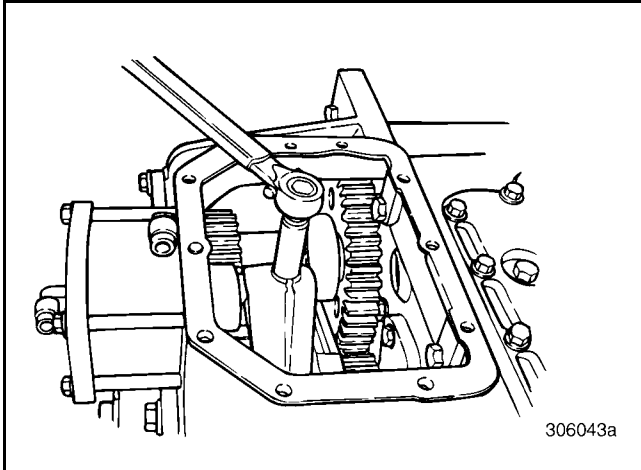

Figure 36 — Removing Shift Fork Locking Bolt

18. Remove the four bolts that secure the shift cylinder to the rear case.

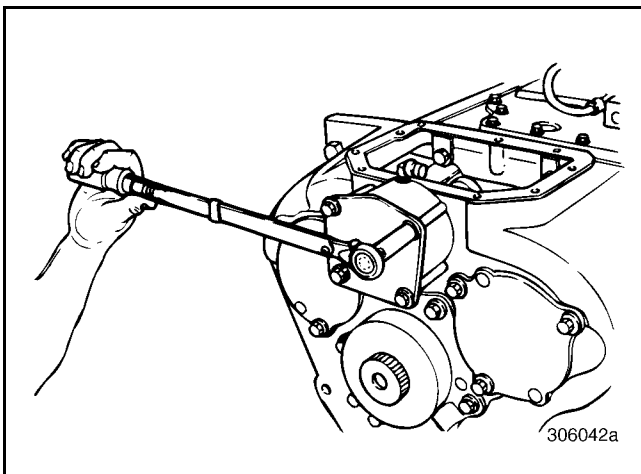

Figure 37 — Removing Shift Cylinder Bolts

19. Remove the shift cylinder cover and O-ring.

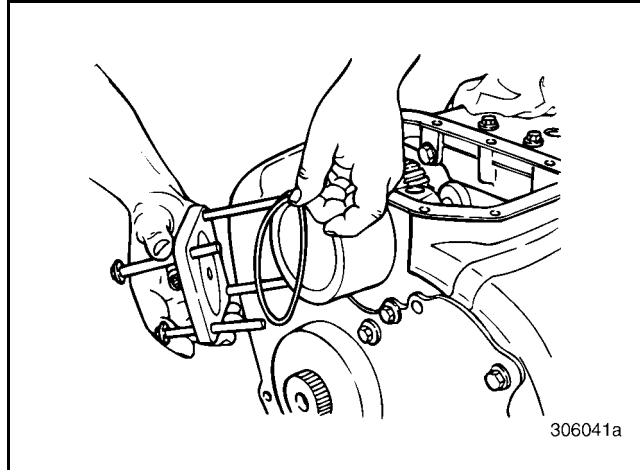

Figure 38 — Removing Shift Cylinder Cover

20. While holding the shift fork, slide the shift cylinder from the rear of the transmission. Remove the shift cylinder-to-rear case gasket.

NOTE

To help remove the shift cylinder, use a plastic mallet to lightly tap on the piston to loosen the shift rail from the fork.

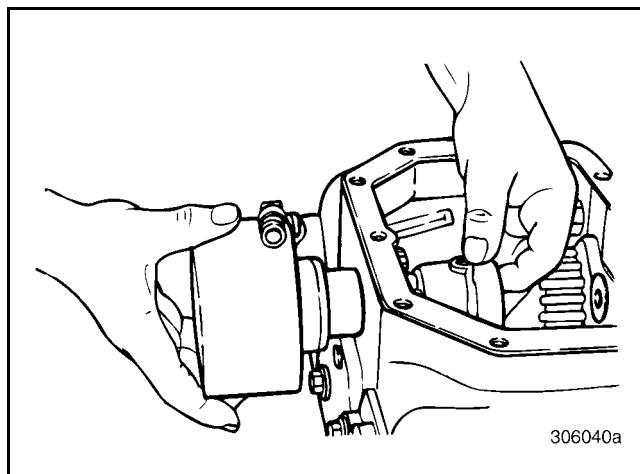

Figure 39 — Removing Shift Cylinder



REPAIR INSTRUCTIONS

21. Remove the range shift cylinder gasket and discard.

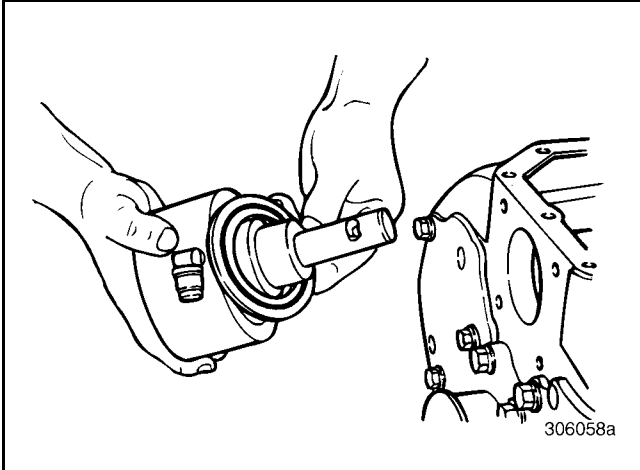

Figure 40 — Removing Range Shift Cylinder Gasket

22. Number the front countershaft front bearing covers and the rear countershaft rear bearing covers, using a grease pencil. Write number 1 on the upper right front cover (viewed from front), number 2 on the upper left front cover (viewed from front) and number 3 on the lower front cover. Write number 1 on the upper left rear cover (viewed from rear), number 2 on the upper right rear cover (viewed from rear) and number 3 on the lower rear cover.

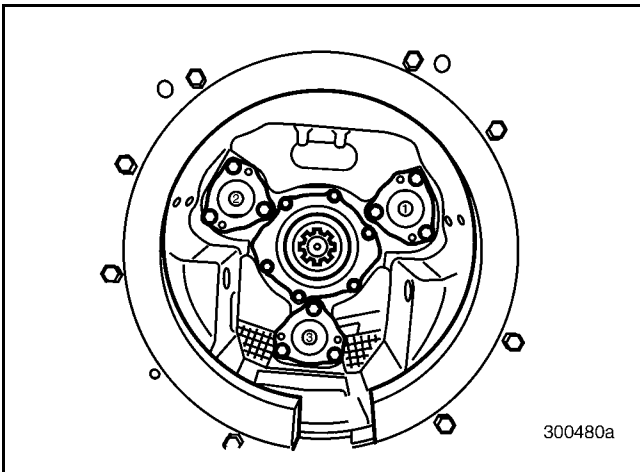

Figure 41 — Mark Front Countershaft Front Bearing Covers for Placement

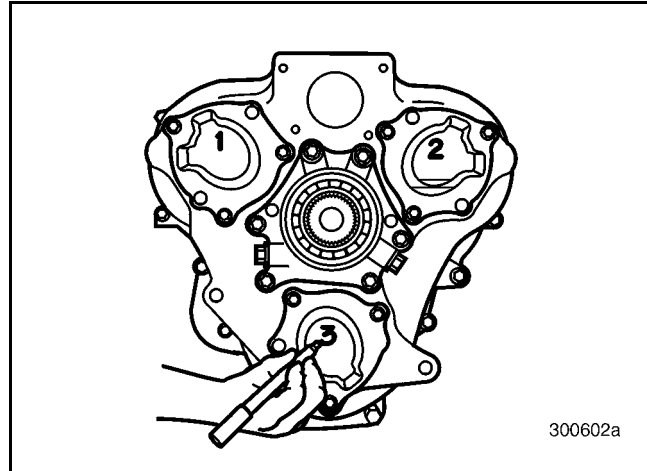

Figure 42 — Mark Rear Countershaft Bearing Covers for Placement

23. Remove all of the rear countershaft bearing cover capscrews.

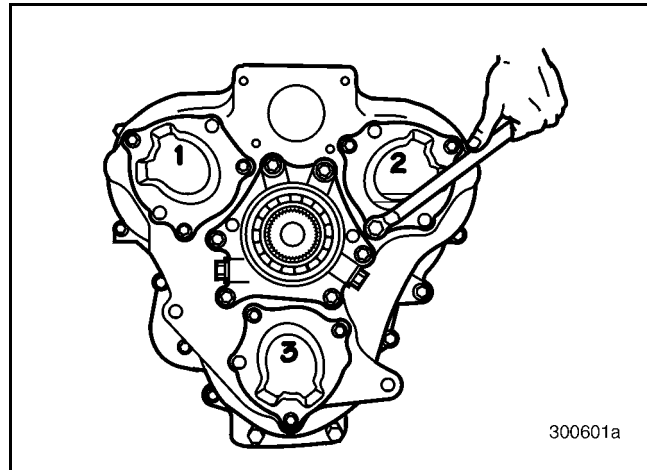

Figure 43 — Removing Rear Countershaft Bearing Cover Capscrews



REPAIR INSTRUCTIONS

24. Remove the jackscrew plugs from the covers.

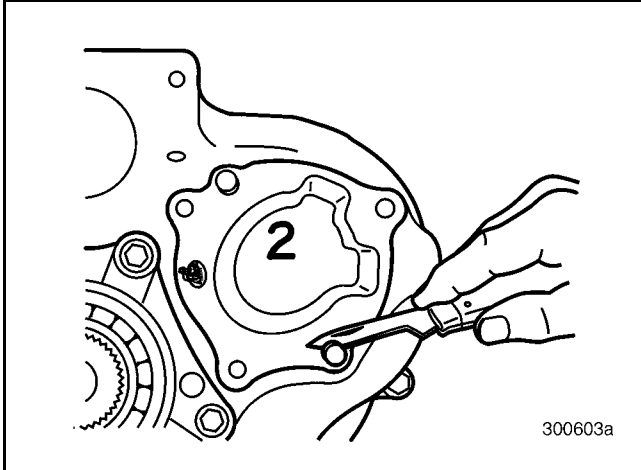

Figure 44 — Removing Jackscrew Plugs

NOTE

Pry the plugs loose using a thin knife-edge or similar tool. Do not cut through plugs during removal. Save for reuse, or replace if necessary.

25. Remove the rear countershaft bearing covers, shims and O-rings. Jackscrew holes are provided to assist removal.

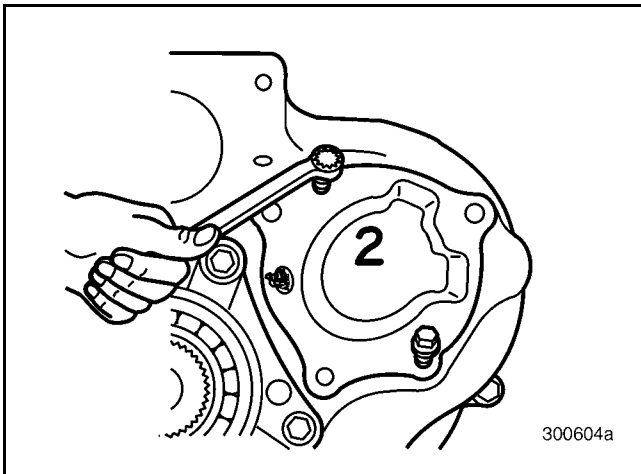

Figure 45 — Removing Bearing Cover

26. Mark the rear countershafts as shown in Figure 46 so they can be installed in the same position during reassembly. Refer to Figure 42 for number locations.

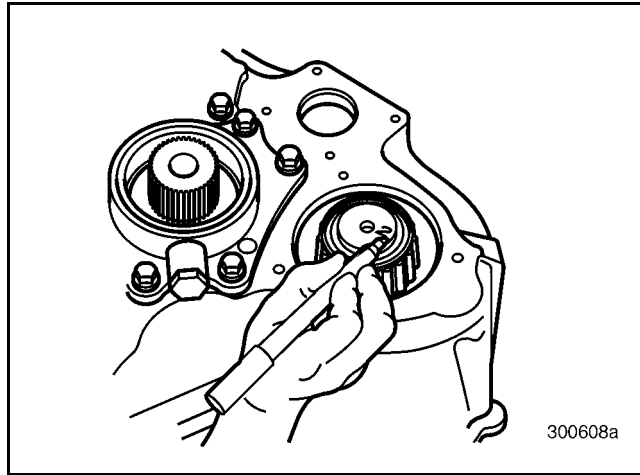

Figure 46 — Marking Rear Countershafts

27. Remove the rear mainshaft bearing cover cap screws. Remove the jackscrew plugs from the cover.

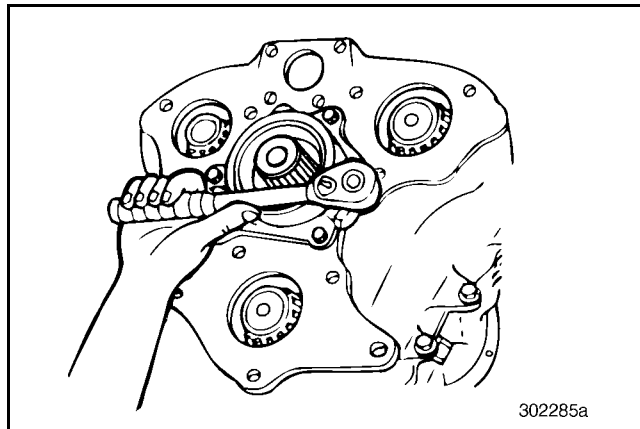

Figure 47 — Removing Rear Mainshaft Bearing Cover Cap screws



REPAIR INSTRUCTIONS

28. Remove the rear mainshaft bearing cover. Jackscrew holes are provided to assist in removal.

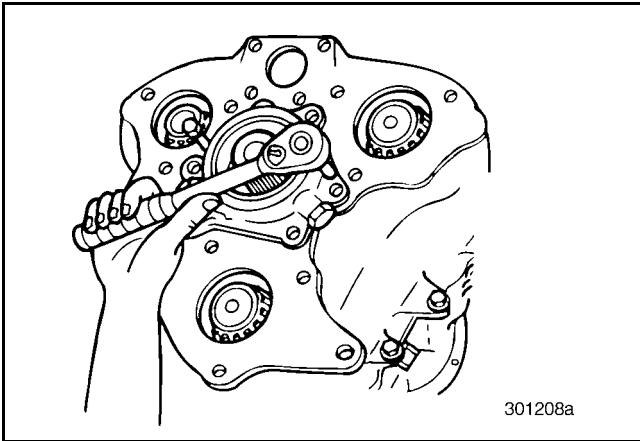

Figure 48 — Removing Rear Mainshaft Bearing Cover Using Jackscrews

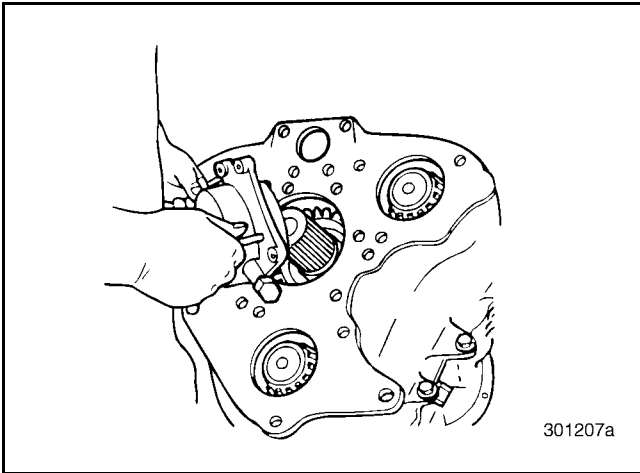

Figure 49 — Rear Mainshaft Bearing Cover Removed

WARNING

When separating the rear case from the front case, make sure the transmission is in the vertical position. The rear countershafts are not supported when the case is removed. They can fall out and cause damage or personal injury.

29. With the transmission in a vertical position (rear case upward), remove the two capscrews located inside the rear case.

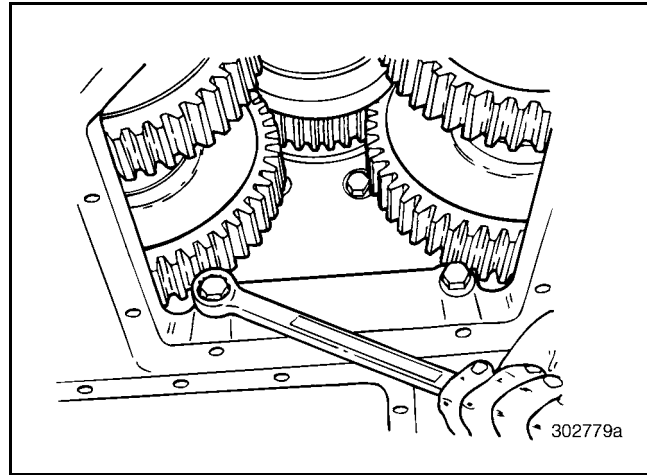

Figure 50 — Removing Outer Rear Case-to-Main Case Capscrews

30. Remove the remaining capscrews and dowel bolts holding the rear case to the main case.

NOTE

Tap dowel bolts out of the rear case using a brass hammer or a combination of a brass hammer and a steel hammer, as long as contact is made with the brass hammer only.

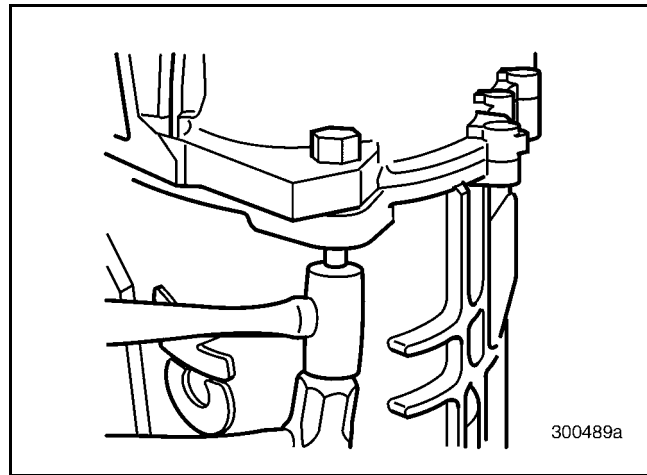

Figure 51 — Removing Dowel Bolts



REPAIR INSTRUCTIONS

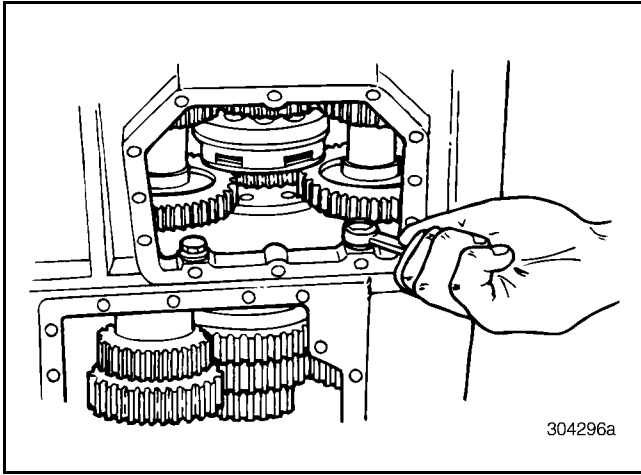

Figure 52 — Removing Inner Rear Case-to-Main Case Capscrews

31. Lift the rear case from the front case. Lift only the case, not the compound gear set or output shaft. Tap on the output shaft to loosen it if necessary.

WARNING

Be sure unit is vertical, so that the countershafts will not fall out when the case is removed.

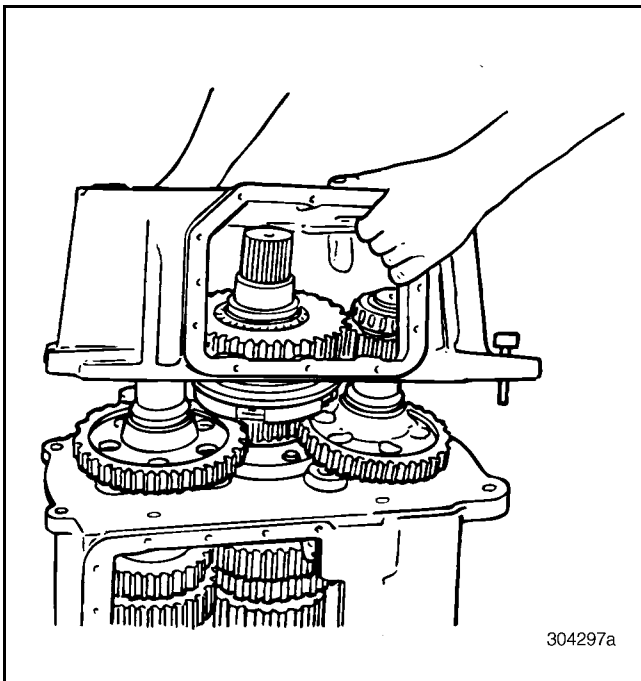

Figure 53 — Removing Rear Case

NOTE

Due to the relatively small size of the rear countershaft Lo gear, it is necessary to first remove each rear countershaft rear bearing cone to allow removal of the rear mainshaft. The rear countershaft bearings overhang the rear mainshaft Lo gear as shown in Figure 54. This bearing overhang prevents mainshaft removal if the bearings are not removed first.

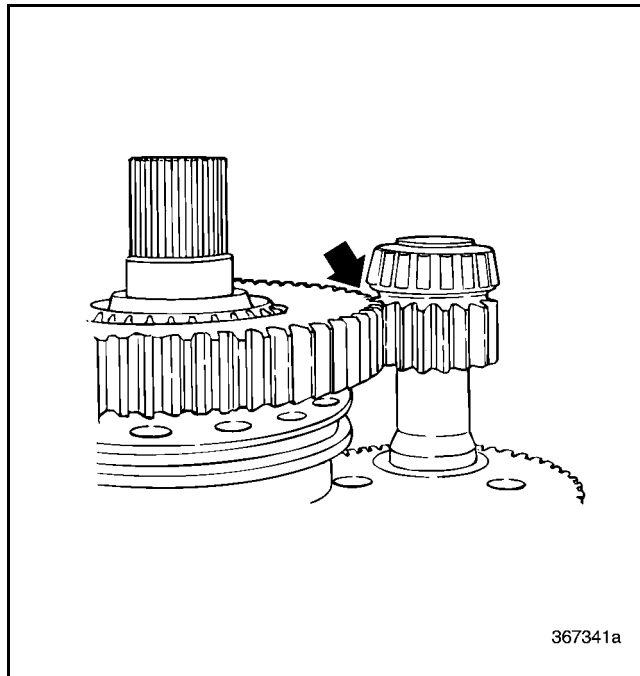

Figure 54 — Rear Countershaft Bearing Overhang



REPAIR INSTRUCTIONS

32. Using a suitable puller arrangement, such as two jaw puller J 21834-4A and bearing separator J 8176 or equivalent, remove all three rear countershaft rear bearing cones.

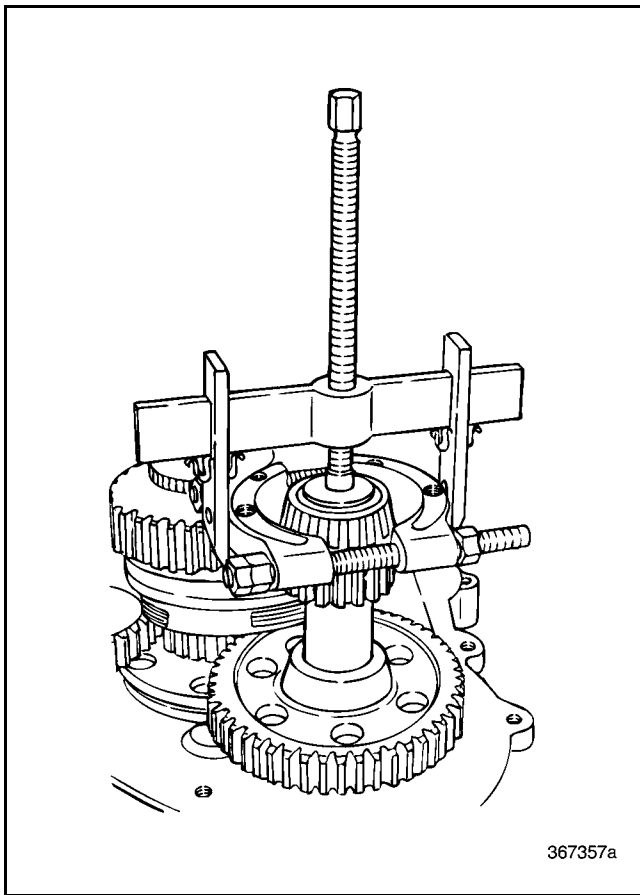

Figure 55 — Removing Rear Countershaft Rear Bearing Cone

33. Remove the synchronizer and rear mainshaft assembly from the main drive gear. Allow the Hi-range (forward) synchronizer plates and backing plate to remain on the main drive gear.

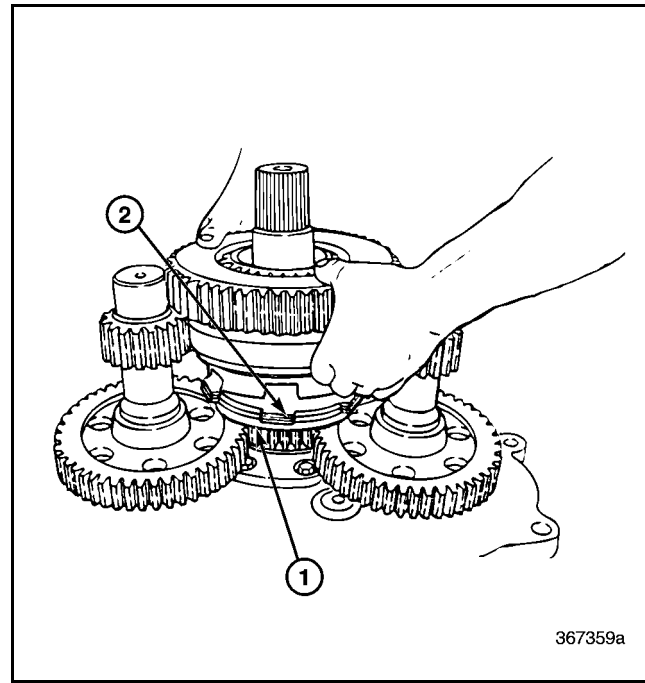

Figure 56 — Removing Synchronizer and Output Shaft

- | | |
|----------------------------------|---------------------------------|
| 1. Main Drive Gear Backing Plate | 2. Hi-Range Synchronizer Plates |
|----------------------------------|---------------------------------|



REPAIR INSTRUCTIONS

34. Remove the Hi-range synchronizer plates, and the main drive gear backing plate.

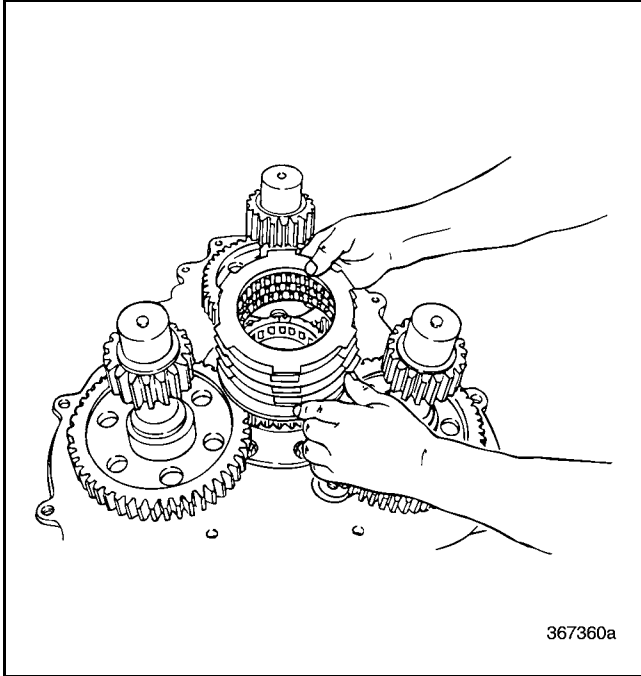

Figure 57 — Removing Hi-Range Synchronizer Plates

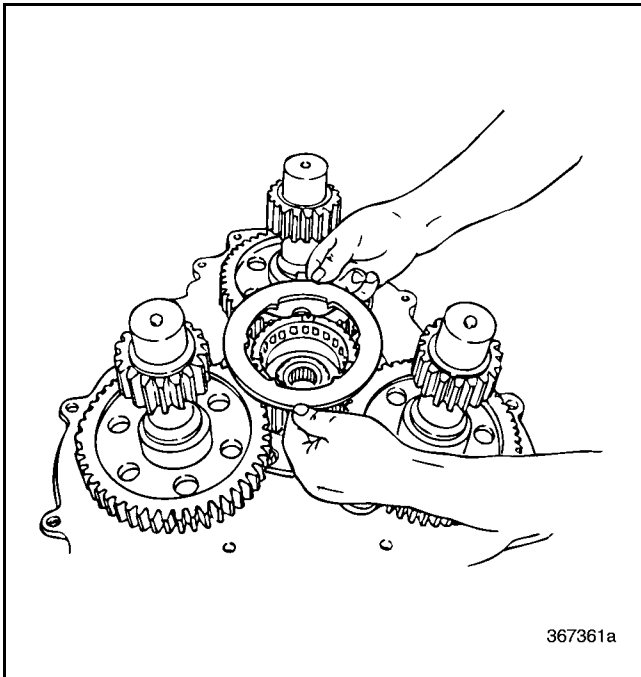

Figure 58 — Removing Main Drive Gear Backing Plate

35. Mark the rear countershafts (if not already done) so that they can be installed in the same location during installation.

NOTE

Notice the gear timing marks. If no timing marks are present, use white paint to mark the gears in three equally spaced marks on the mainshaft. The countershaft mating gear teeth must be marked in alignment with the shaft keyway. Mark the mainshaft main drive gear-to-countershaft gears.

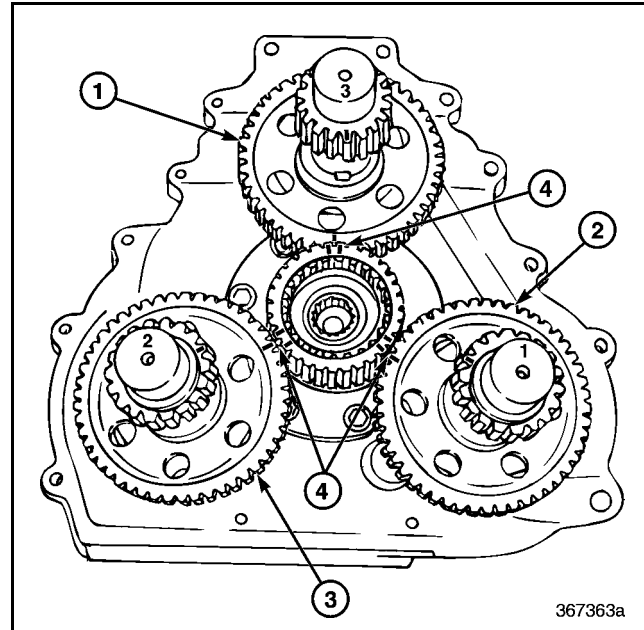

Figure 59 — Main Drive Gear-to-Countershaft Timing

1. Lower Countershaft (No. 3)	3. Upper Right Countershaft (No. 2)
2. Upper Left Countershaft (No. 1)	4. Main Drive Gear-to- Countershaft Timing Marks



REPAIR INSTRUCTIONS

36. Remove the three rear countershafts from the rear of the transmission.

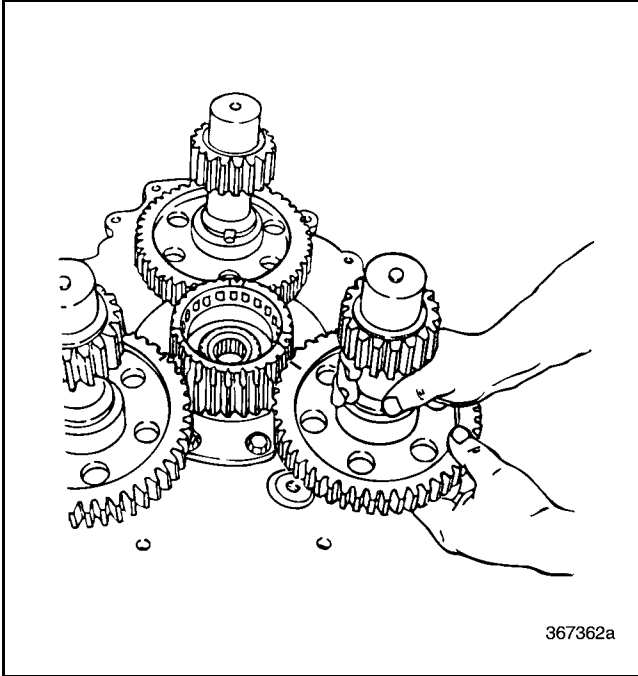

Figure 60 — Removing Rear Case Countershafts

37. Remove the snap ring from inside the compound main drive gear.

SERVICE HINT

To help in removing the compound main drive gear snap ring, use a pry bar to slightly lift the front mainshaft during removal. This allows more clearance and frees the snap ring from the snap ring groove.

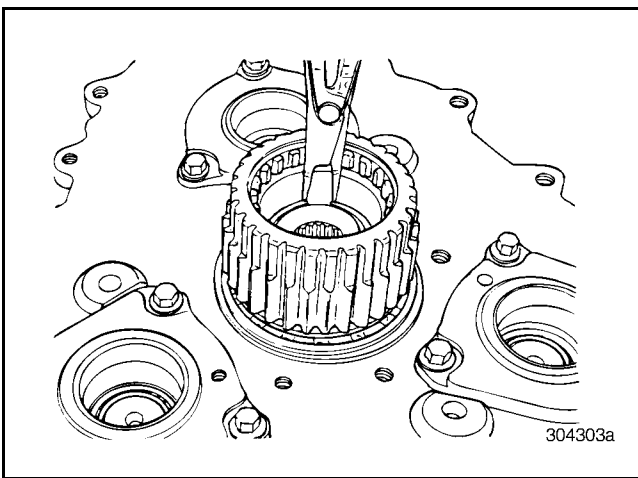

Figure 61 — Removing Main Drive Gear Snap Ring

38. Remove the compound main drive gear retaining plate capscrews.

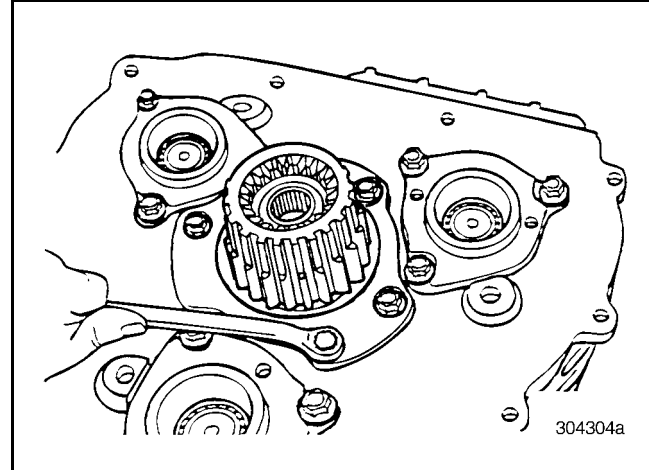

Figure 62 — Removing Compound Main Drive Gear Retaining Plate Capscrews

39. Remove the compound main drive gear retaining plate.

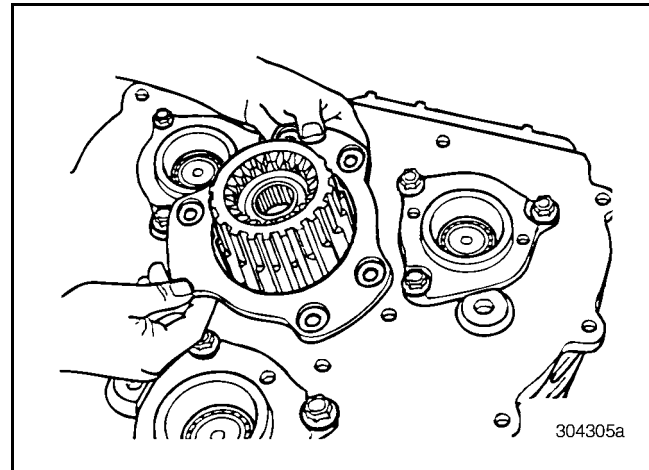

Figure 63 — Removing Compound Main Drive Gear Retaining Plate



REPAIR INSTRUCTIONS

40. Remove the compound main drive gear (with ball bearing) and the spacer from the front mainshaft.

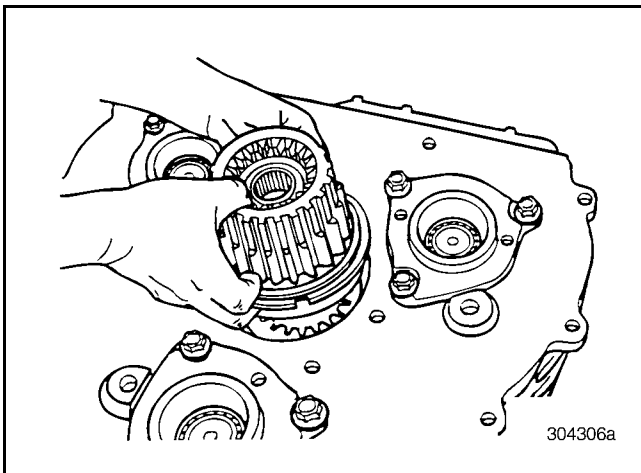

Figure 64 — Removing Main Drive Gear from Front Mainshaft

41. Using suitable snap ring pliers, remove the mainshaft snap ring directly behind the previously removed spacer.

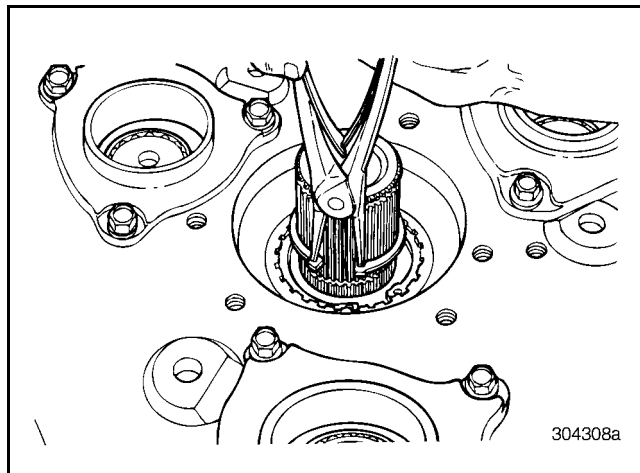

Figure 66 — Spacer Mainshaft Snap Ring

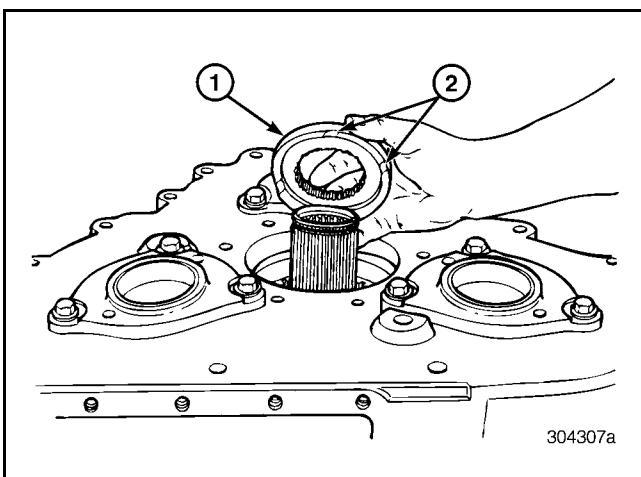

Figure 65 — Removing Spacer from Front Mainshaft

1. Spacer

2. Spacer Lubrication Grooves

42. Mark the front countershaft rear bearing covers and front countershafts for correct placement during reassembly.

NOTE

If not already done, use a grease pencil to number the front countershaft rear bearing covers. Write number 1 on the upper left rear cover (viewed from rear), number 2 on the upper right rear cover (viewed from rear), and number 3 on the lower rear cover. Also, mark the front countershafts (use the same numbers and locations indicated above) so that they can be installed in the same position during reassembly.

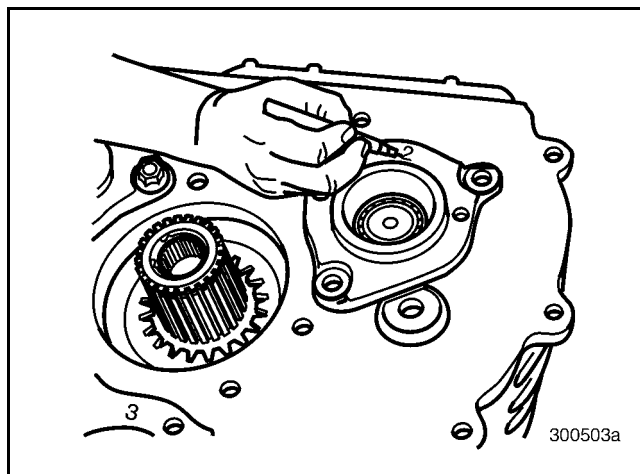

Figure 67 — Mark Front Countershafts and Front Countershaft Rear Bearing Covers



REPAIR INSTRUCTIONS

43. Position the transmission case horizontally. Remove the main drive pinion bearing cover capscrews.

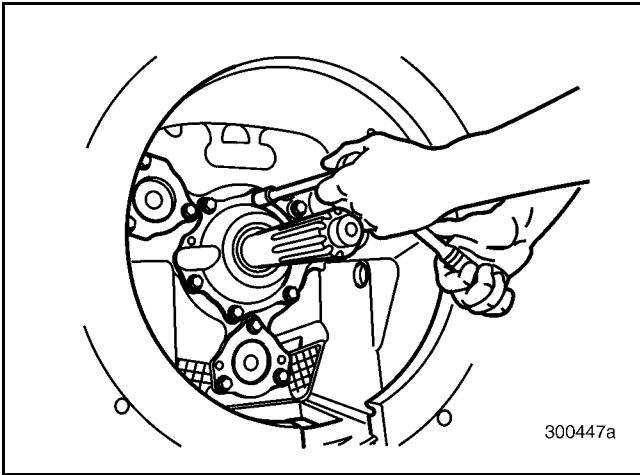

Figure 68 — Removing Pinion Bearing Cover Capscrews

44. Remove the main drive pinion bearing assembly. Jackscrew holes are provided to assist in removal.

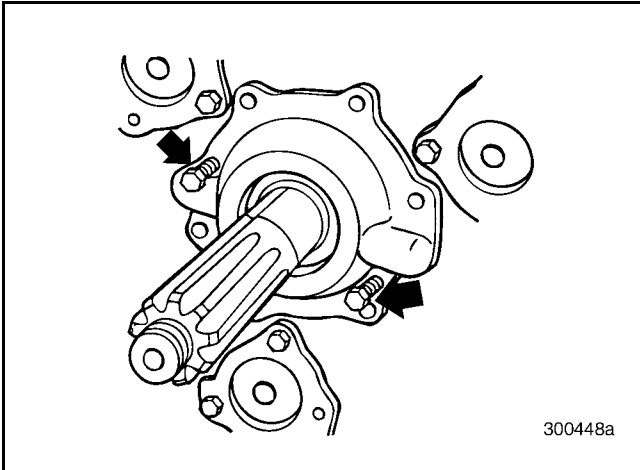

Figure 69 — Use Jackscrews to Remove Main Drive Pinion Assembly

45. Remove main drive pinion bearing assembly from the case.

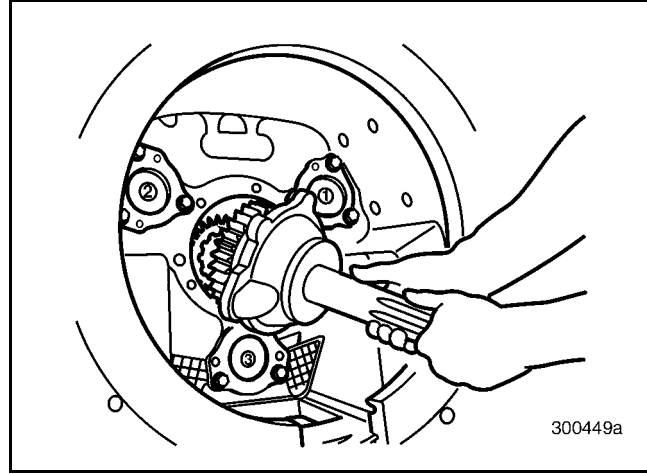

Figure 70 — Removing Main Drive Pinion Assembly

46. Remove the exposed sliding clutch.

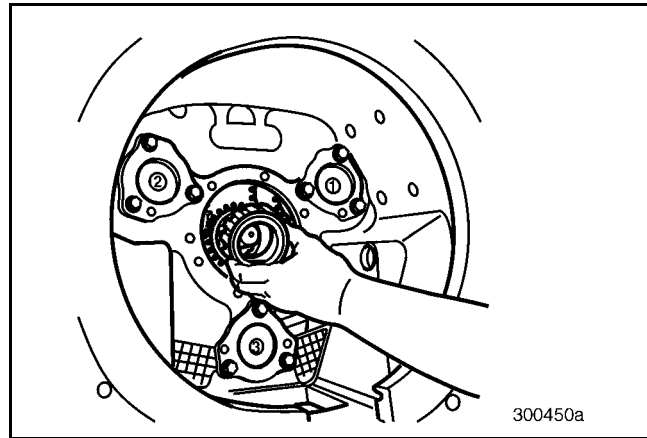

Figure 71 — Removing Sliding Clutch



REPAIR INSTRUCTIONS

47. Remove the No. 2 (upper left) front countershaft front bearing cover capscrews.

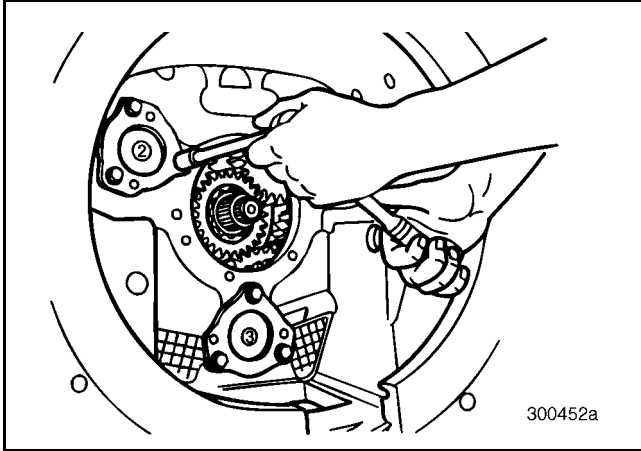

Figure 72 — Removing No. 2 Front Countershaft Front Bearing Cover Capscrews

48. Using jackscrews, remove the No. 2 (upper left) front countershaft front bearing cover.

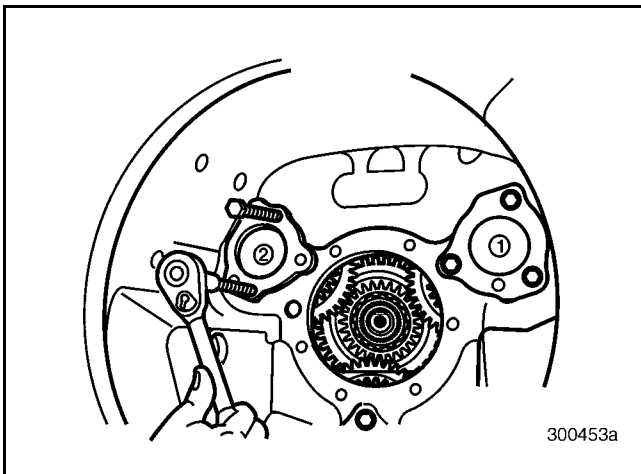

Figure 73 — Removing No. 2 Front Countershaft Front Bearing Cover

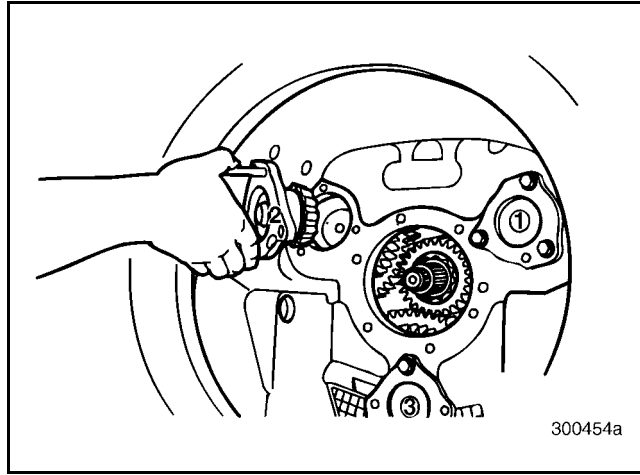

Figure 74 — No. 2 Front Countershaft Front Bearing Cover Removed

49. Remove the No. 2 (upper right) front countershaft rear bearing cover capscrews.

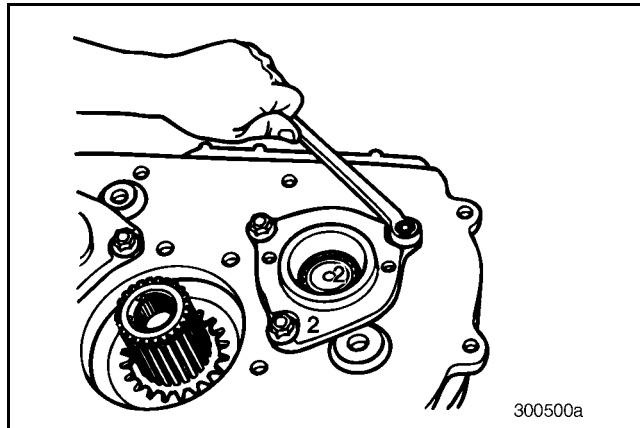

Figure 75 — Removing No. 2 Front Countershaft Rear Bearing Cover Capscrews



REPAIR INSTRUCTIONS

50. Remove the No. 2 (upper right) front countershaft rear bearing cover, using jackscrews. Remove shim with cover.

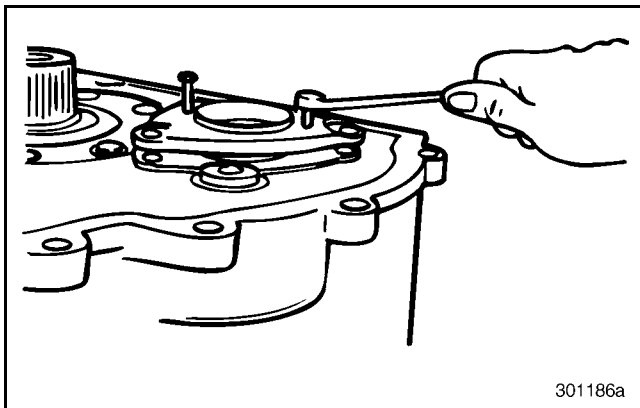

Figure 76 — Removing No. 2 Front Countershaft Rear Bearing Cover

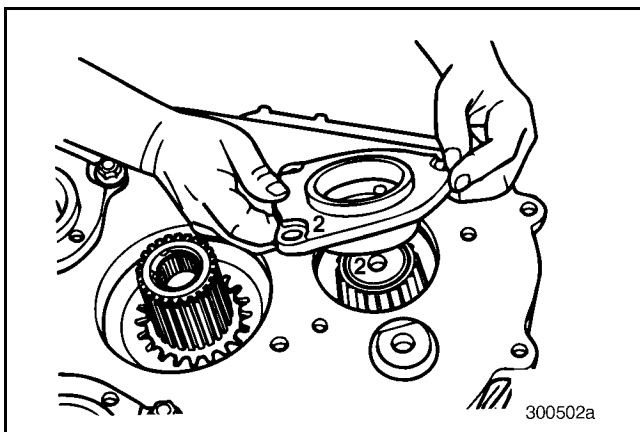

Figure 77 — No. 2 Front Countershaft Rear Bearing Cover Removed

51. Using a pry bar, move the mainshaft rearward in the case to relieve pressure on the snap rings and free mainshaft gears from countershaft gears.
52. Remove the No. 2 countershaft (upper right, as viewed from rear) from the case.

SERVICE HINT

Removal is easier if the transmission is in the vertical position.

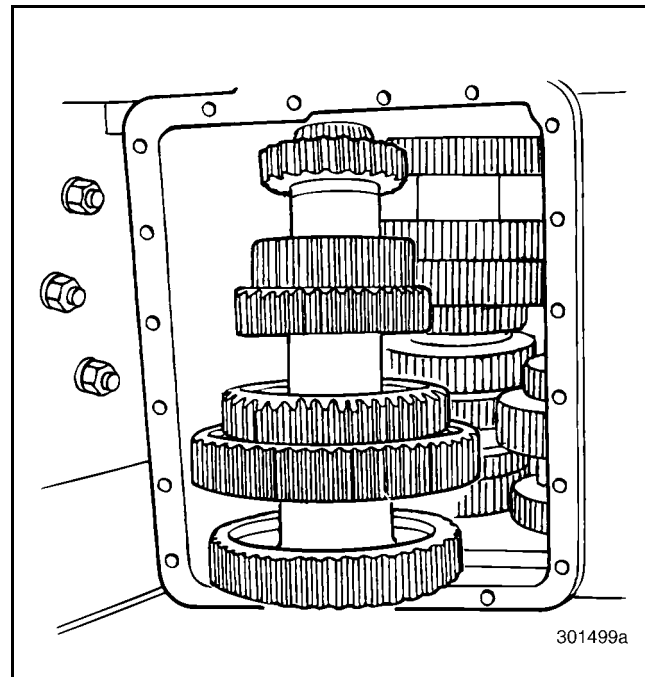

Figure 78 — Removing No. 2 Countershaft from Transmission Case

53. Using tool J 34630 or a slide hammer, remove the upper right reverse idler shaft (next to No. 2 countershaft location). To prevent damage to the reverse idler gear, catch the gear as it separates from the shaft.

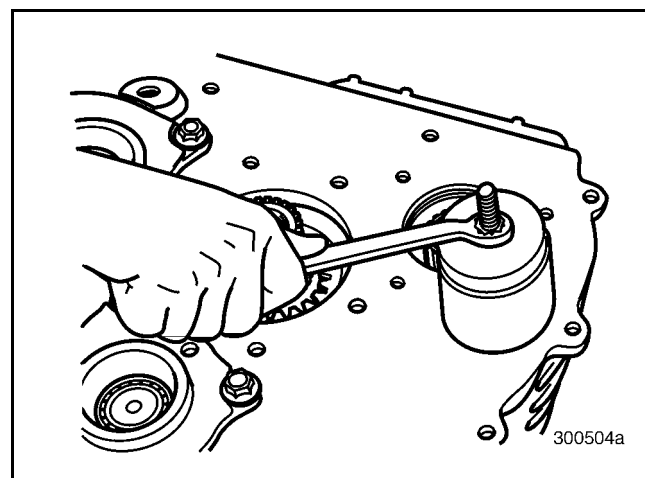

Figure 79 — Using Tool J 34630 to Remove Reverse Idler Shaft



REPAIR INSTRUCTIONS

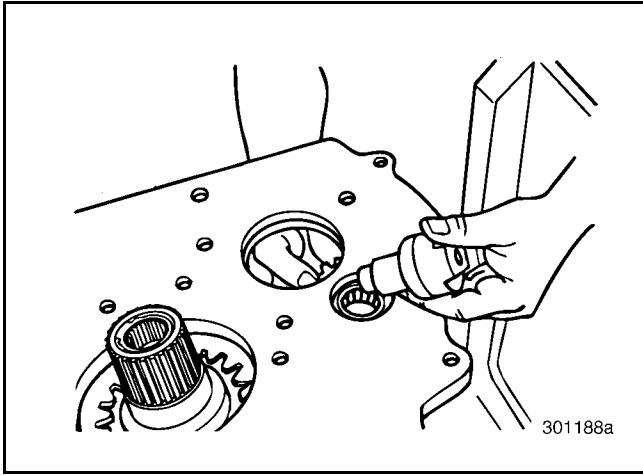

Figure 80 — Removing Reverse Idler Gear and Shaft

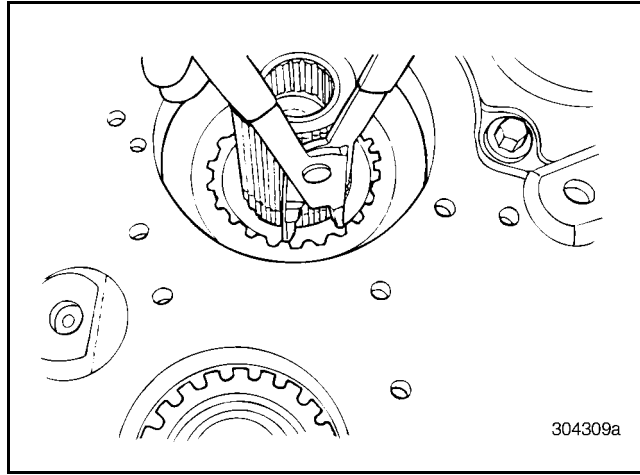

Figure 82 — Removing Snap Ring from Inside Reverse Speed Gear

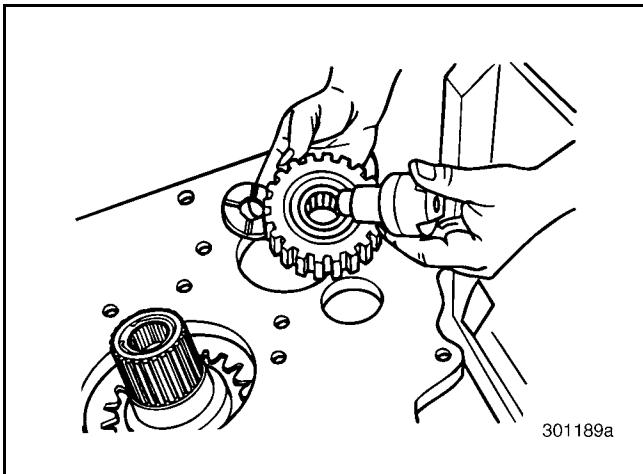

Figure 81 — Reverse Idler Gear and Shaft Removed

54. Remove the No. 1 (upper left) front countershaft rear bearing cover capscrews.
55. Using jackscrews, remove the No. 1 (upper left) front countershaft rear bearing cover. Remove shims with cover.
56. Using tool J 34630 or a slide hammer, remove the upper left reverse idler shaft (next to No. 1 countershaft). To prevent damage to the reverse idler gear, catch the gear as it separates from the shaft.
57. Remove the snap ring from inside the reverse speed gear.

58. Remove the external-toothed and internal-toothed thrust washers from inside the reverse speed gear.

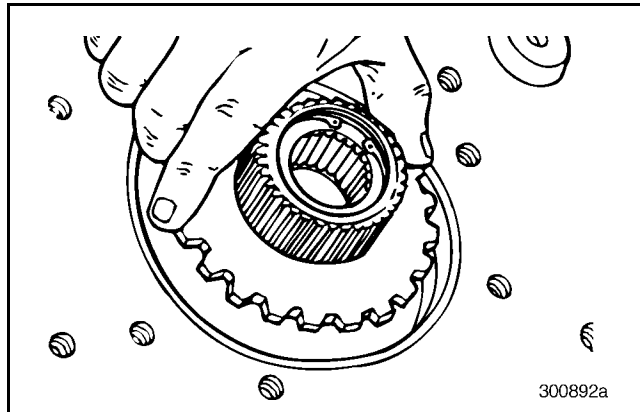

Figure 83 — Removing External-Toothed Thrust Washer

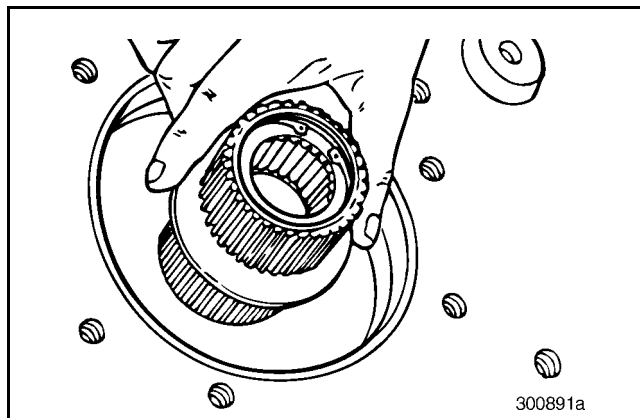

Figure 84 — Removing Internal-Toothed Thrust Washer



REPAIR INSTRUCTIONS

59. Remove the reverse gear mainshaft snap ring.

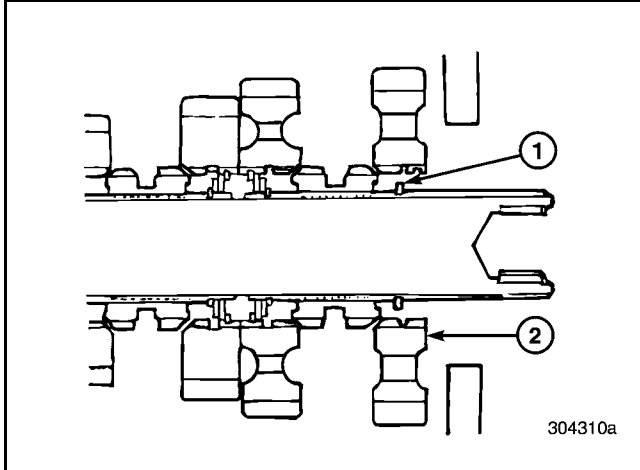

Figure 85 — Removing Reverse Gear Mainshaft Snap Ring

1. Snap Ring	2. Reverse Gear
--------------	-----------------

60. From top of case, slide the reverse gear and reverse/first sliding clutch forward.

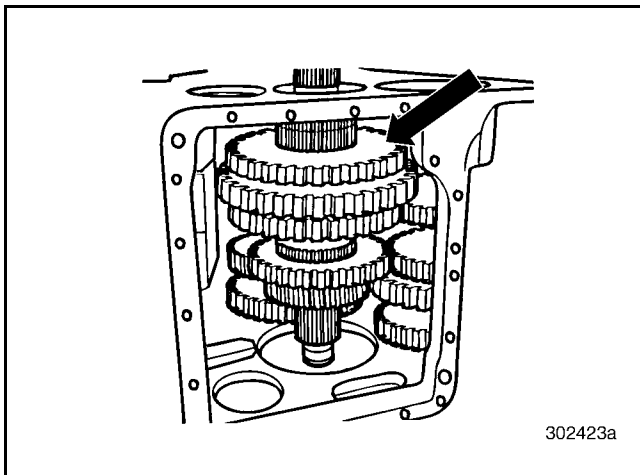

Figure 86 — Sliding Reverse Gear and Reverse/First Clutch Forward

61. Using a pry bar, move the rear end of the No. 1 (upper left) countershaft away from the mainshaft as far as possible without damaging the bearing. Block the countershaft in this position, using wadding made from rags.

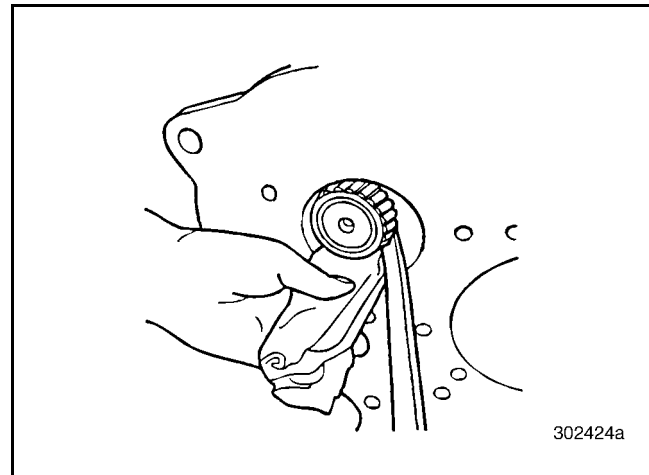

Figure 87 — Moving and Blocking No. 1 (Upper Left) Countershaft Away from Mainshaft

62. Tip the front end of the mainshaft outward and remove it from the case.

NOTE

The reverse gear is free on the mainshaft and can fall off when handling the mainshaft assembly.

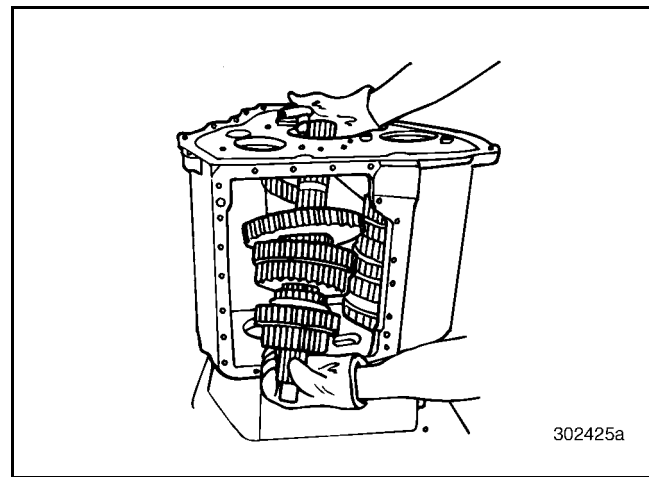

Figure 88 — Removing the Mainshaft



REPAIR INSTRUCTIONS

63. Remove the No. 3 (lower) front countershaft rear bearing cover capscrews.
64. Using jackscrews, remove the No. 3 (lower) front countershaft rear bearing cover. Remove shims with cover.
65. Using tool J 34630 or a slide hammer, remove the lower reverse idler shaft (next to No. 3 countershaft). To prevent damage to the reverse idler gear, catch the gear as it separates from the shaft.
66. Remove the No. 1 (upper left) front countershaft by pulling and tilting the front end of the shaft upward.

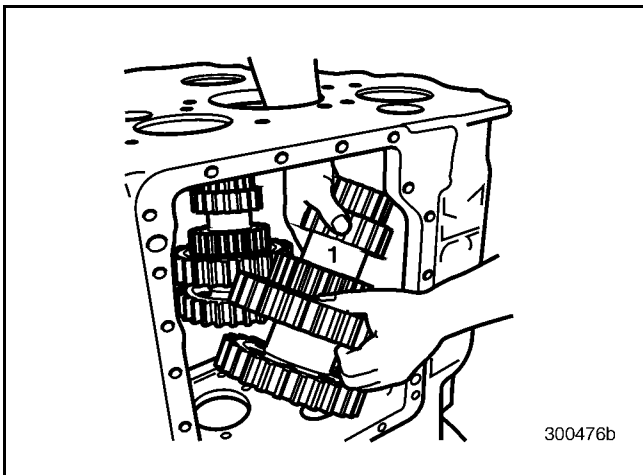

Figure 89 — Removing No. 1 Upper Left Countershaft

67. Remove the No. 3 (lower) countershaft by pulling and tilting the front end of the shaft upward.

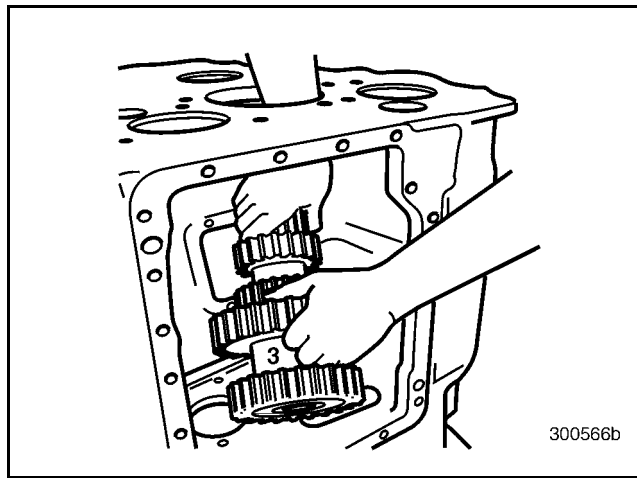

Figure 90 — Removing No. 3 Lower Countershaft

68. Remove the remaining No. 1 (upper right, viewed from front) and No. 3 (lower) front countershaft front bearing cover capscrews and bearing covers. Use jackscrews to remove the covers.

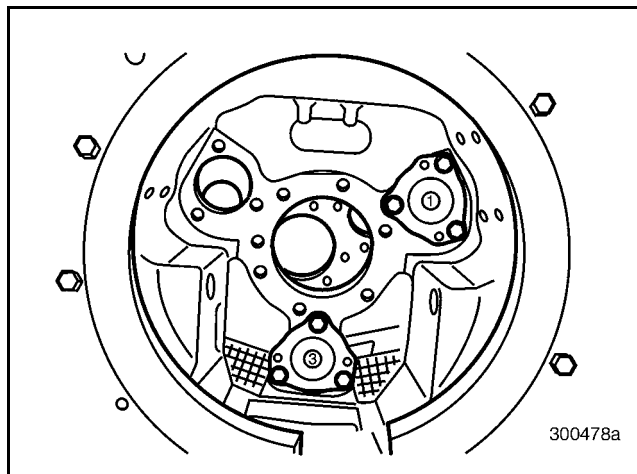

Figure 91 — Remaining No. 1 and No. 3 Front Countershaft Bearing Covers



REPAIR INSTRUCTIONS

TRANSMISSION COMPONENT DISASSEMBLY [320]

NOTE

Unless a complete overhaul is necessary, remove only the parts that are required to repair the assembly. Do not disturb parts that have a heavy press fit (interference fit) unless replacement of the part is necessary. When replacement is necessary, use proper pullers and press setups to prevent damage to usable parts.

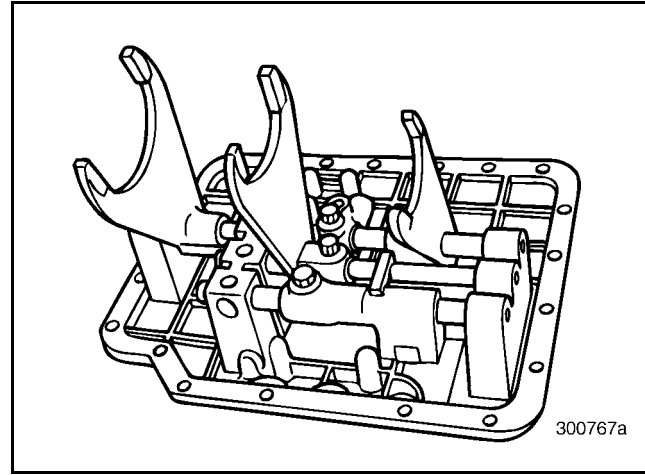

Figure 93 — Shift Cover Assembly

Main Case Shift Cover Disassembly [323]

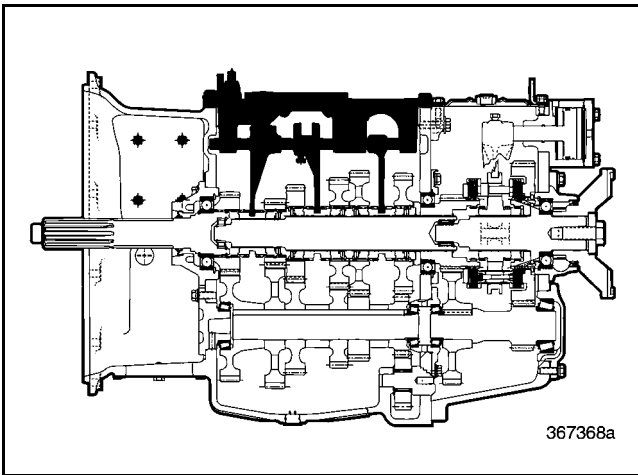

Figure 92 — Main Case Shift Cover Component Locator



REPAIR INSTRUCTIONS

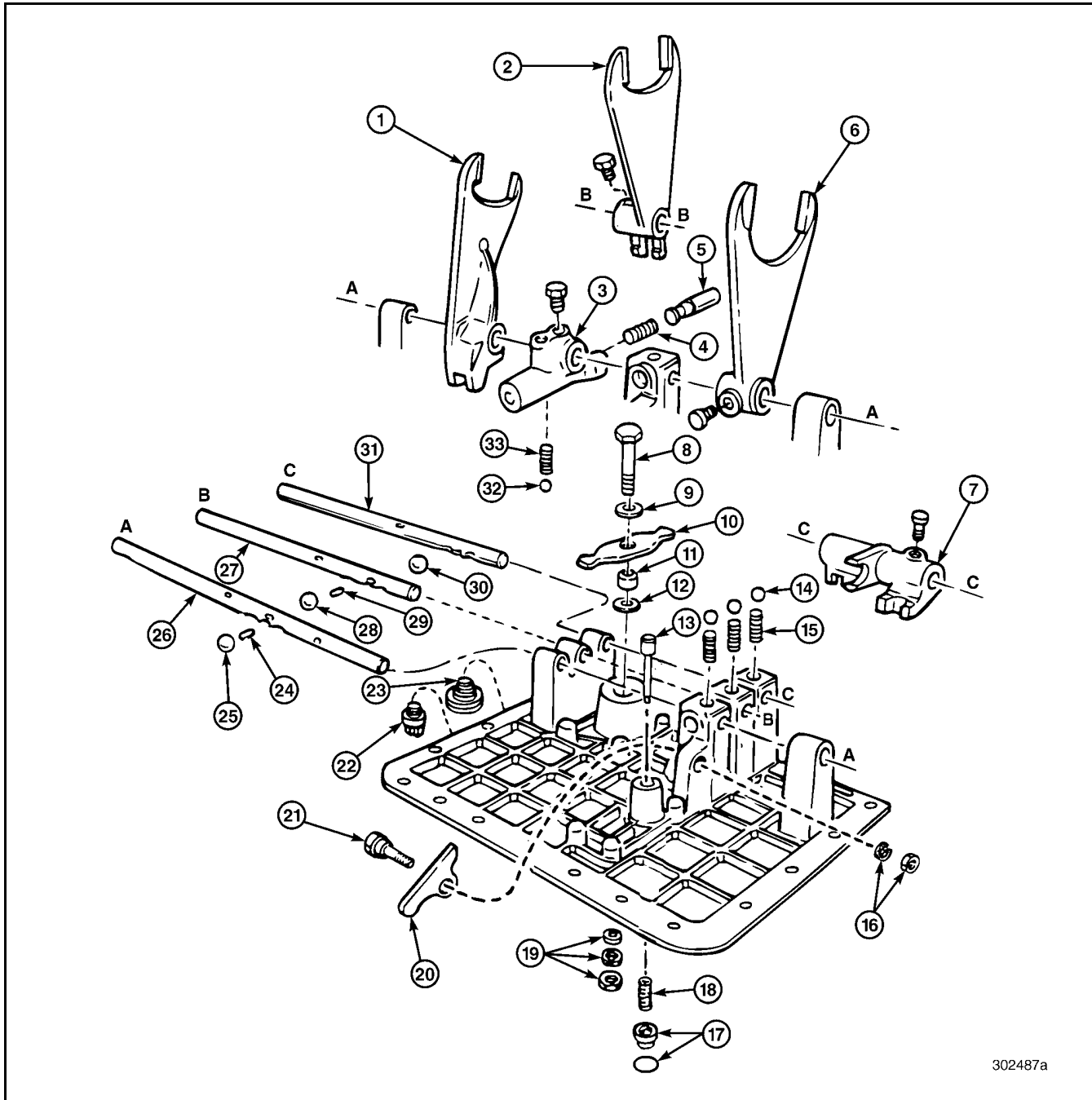

Figure 94 — Exploded View of Main Case Shift Cover

1. 4th/5th Shift Fork	12. Washer	23. Breather
2. 2nd/3rd Shift Fork	13. Interlock Pin	24. Interlock Pin
3. 1st/Reverse Shifter	14. Poppet Ball	25. Interlock Ball
4. Shifter Body Spring (Interlock)	15. Poppet Ball Spring	26. 1st/Reverse Shift Rail
5. Shifter Body Plunger (Interlock)	16. Interlock Rocker Hardware	27. 2nd/3rd Shift Rail
6. 1st/Reverse Shift Fork	17. Interlock Sleeve and O-Ring	28. Interlock Ball
7. 4th/5th Shifter	18. Interlock Spring	29. Interlock Pin
8. 4th/5th Rocker Pin	19. 4th/5th Rocker Pin Hardware	30. Interlock Ball
9. Washer	20. Interlock Rocker	31. 4th/5th Shift Rail
10. 4th/5th Rocker Arm	21. Interlock Rocker Bolt	32. 1st/Reverse Shifter Ball
11. Bushing	22. Pipe Plug	33. 1st/Reverse Shifter Spring



REPAIR INSTRUCTIONS

1. Remove the nut and washers from the interlock rocker bolt.

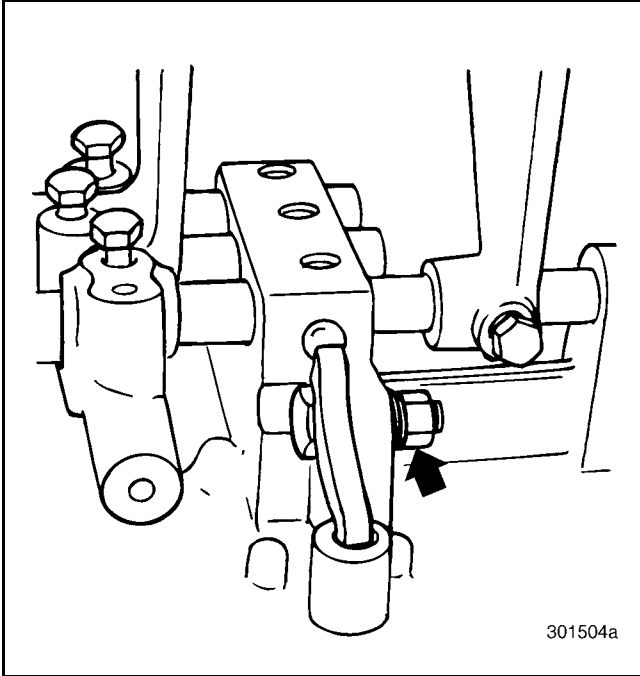

Figure 95 — Remove Nut and Washers

2. Remove the interlock rocker and bolt from the cover.

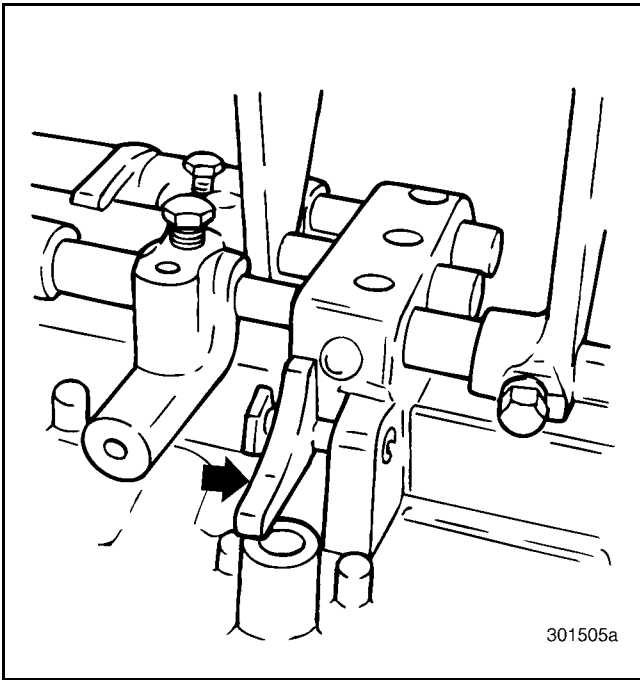

Figure 96 — Remove Interlock Rocker and Bolt

3. Remove the interlock ball from the cover.

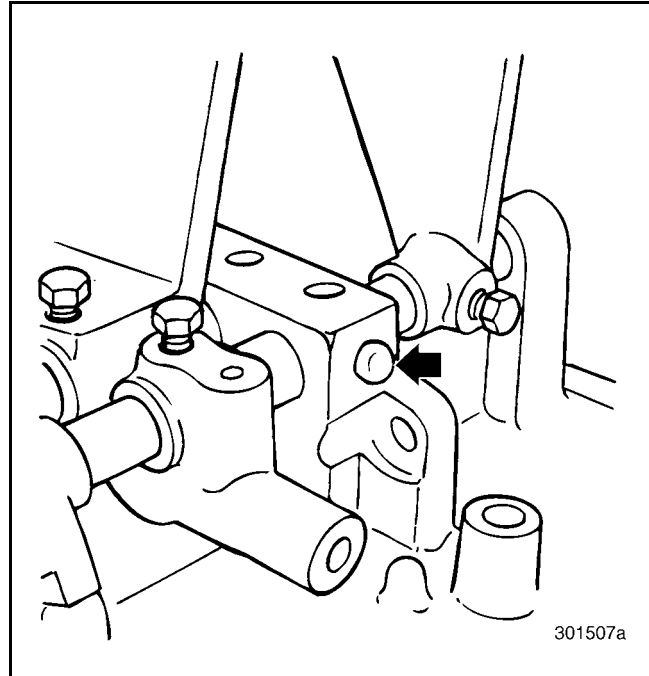

Figure 97 — Remove Interlock Ball from Cover

4. Remove the setscrew from the first/reverse shift fork.

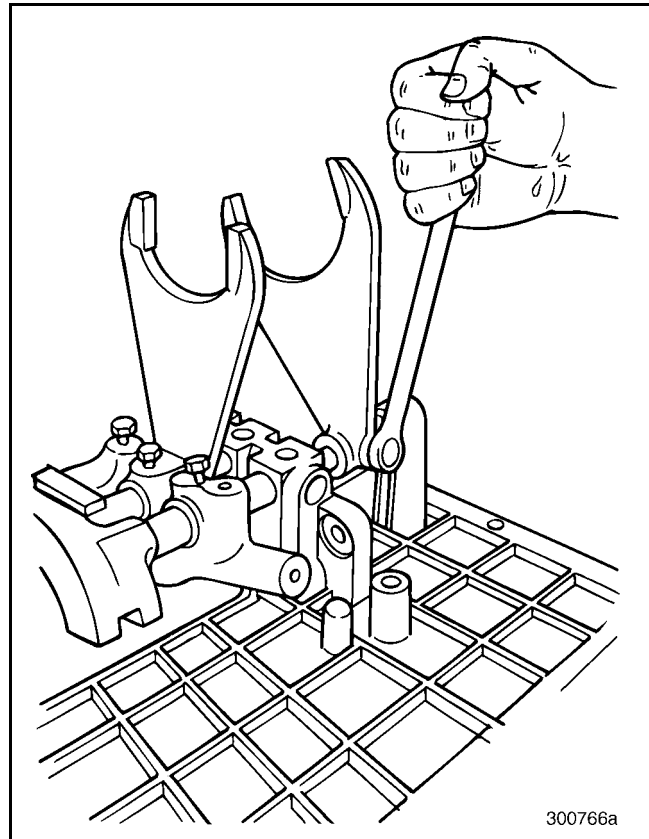

Figure 98 — Removing Setscrew from First/Reverse Shift Fork



REPAIR INSTRUCTIONS

5. Remove the setscrew from the first/reverse shifter.

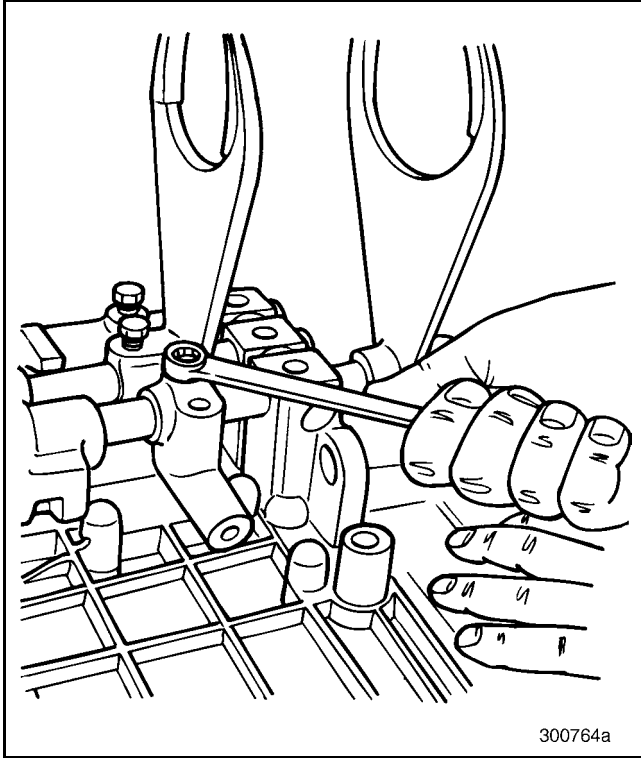

Figure 99 — Removing Setscrew from First/Reverse Shifter

6. Slide the first/reverse shift rail to the left and remove the interlock pin.

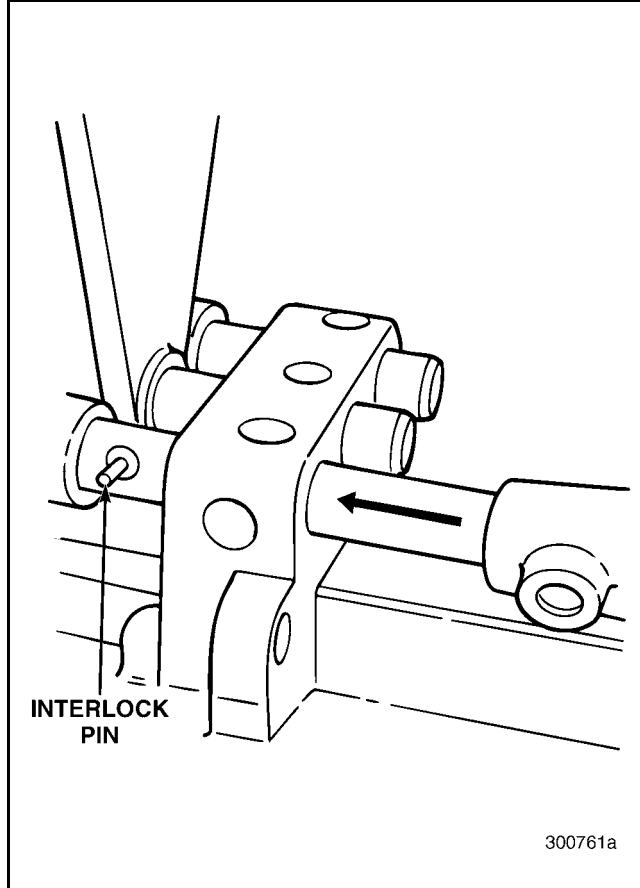

Figure 100 — Sliding First/Reverse Shift Rail



REPAIR INSTRUCTIONS

7. Remove the first/reverse shift fork from the cover.

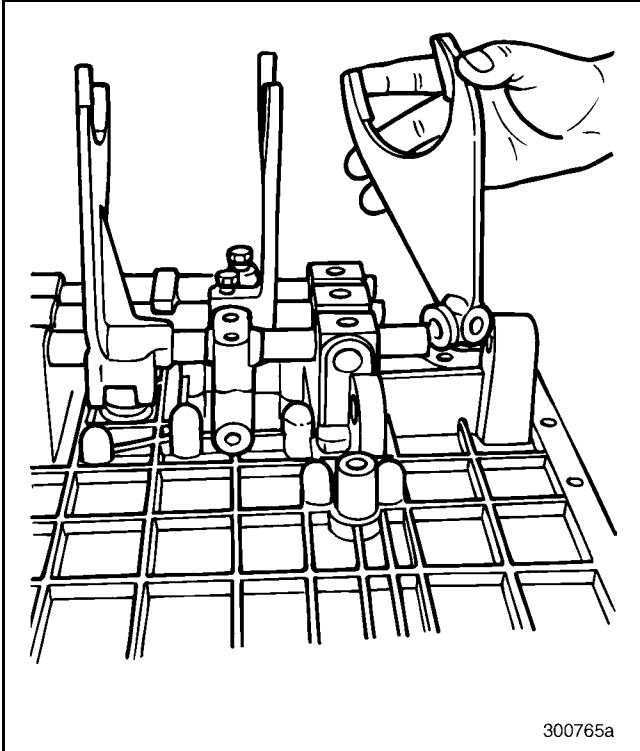

Figure 101 — Removing First/Reverse Shift Fork

8. Push the first/reverse shift rail forward, using a metal bar or large screwdriver. Hold a shop towel over the top opening. The shop towel prevents the spring and ball under the rail from popping out and becoming lost.

⚠ WARNING

Poppet balls are spring loaded and may cause injury when released.

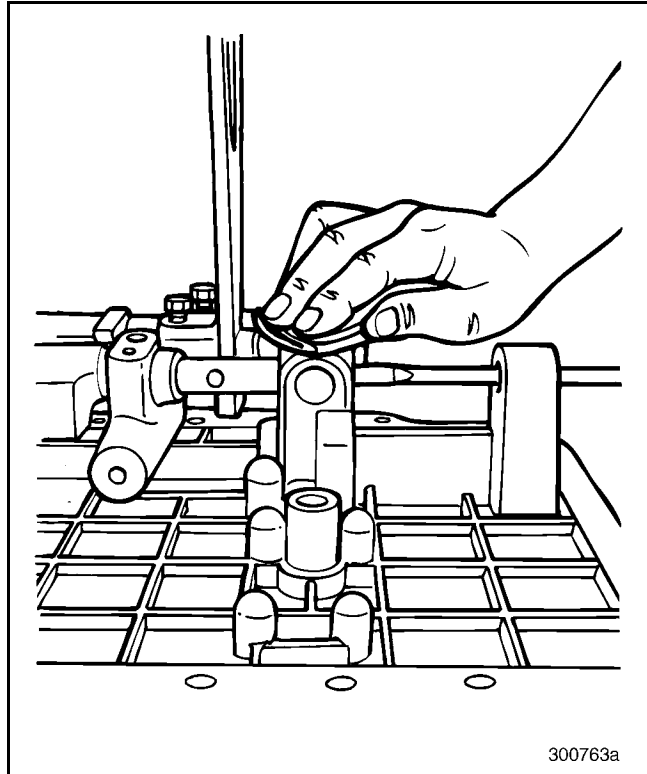

Figure 102 — Pushing First/Reverse Shift Rail Forward



REPAIR INSTRUCTIONS

9. Remove the poppet ball and spring from the first/reverse shift rail vertical pocket in line with the rail.

SERVICE HINT

A magnet is helpful in removing the poppet ball and spring.

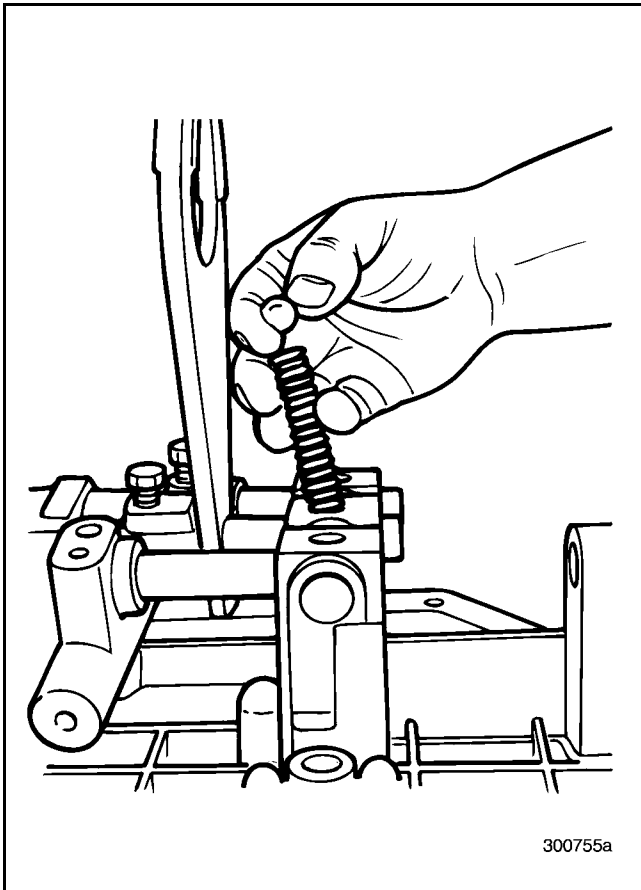

Figure 103 — Removing Poppet Ball and Spring

10. Remove the interlock ball from the horizontal pocket between the first/reverse shift rail and the second/third shift rail.

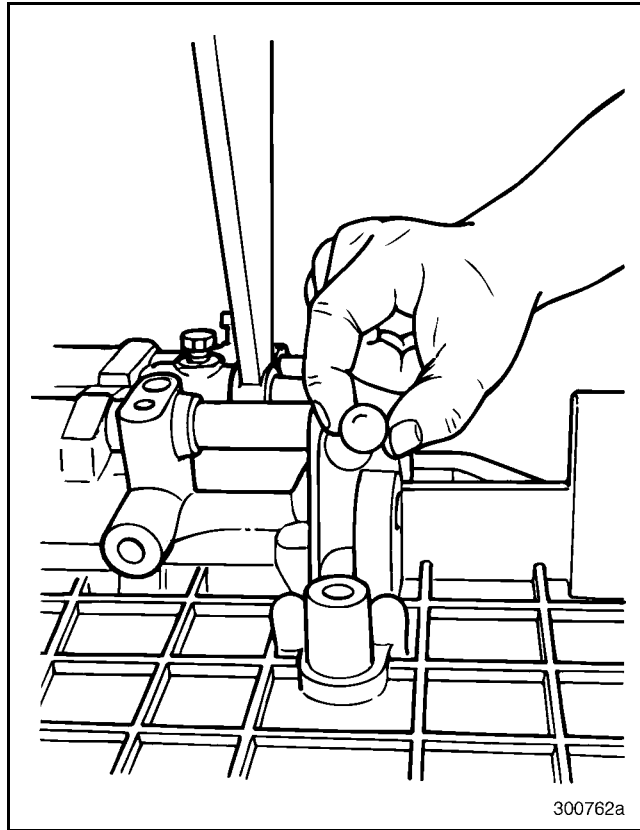

Figure 104 — Removing Interlock Ball



REPAIR INSTRUCTIONS

11. Continue sliding the first/reverse shift rail forward to remove the first/reverse shifter.

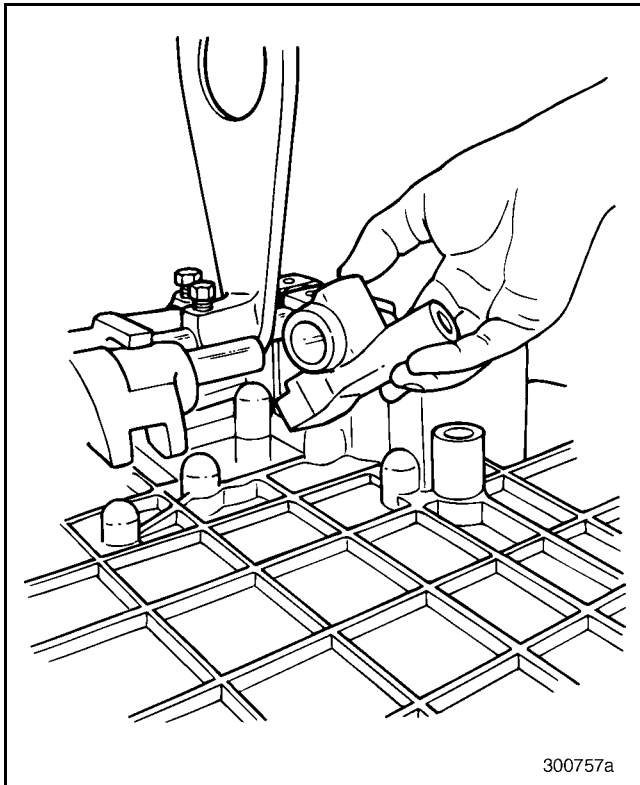

Figure 105 — Removing First/Reverse Shifter

12. Slide the first/reverse shift rail from the shift cover and at the same time, remove the fourth/fifth shift fork.

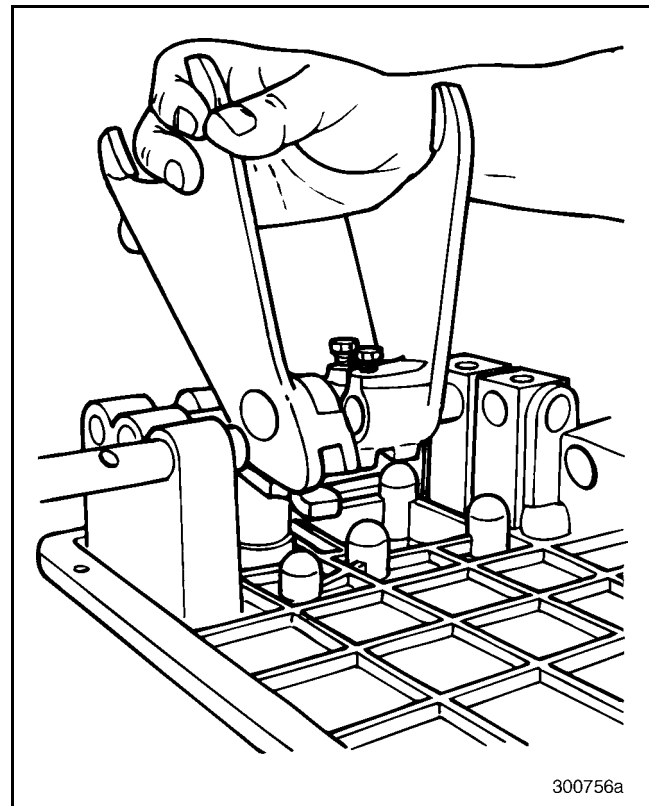

Figure 106 — Removing Fourth/Fifth Shift Fork



REPAIR INSTRUCTIONS

13. Remove the setscrew from the second/third shift fork.

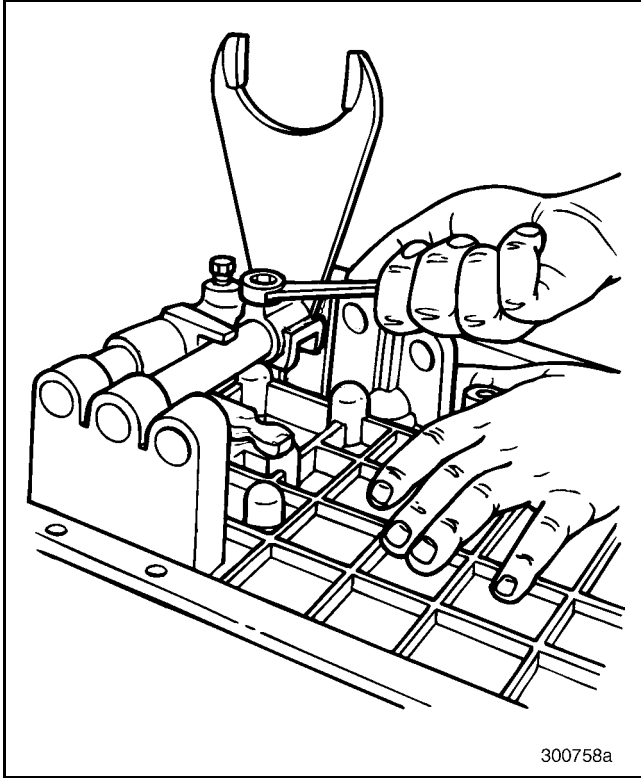

Figure 107 — Removing Setscrew from Second/Third Shift Fork

14. Push the second/third shift rail forward, using a metal bar or large screwdriver. Hold a shop towel over the top opening. The shop towel prevents the spring and ball under the rail from popping out and becoming lost.

⚠ WARNING

Poppet balls are spring loaded and can cause injury when they are released.

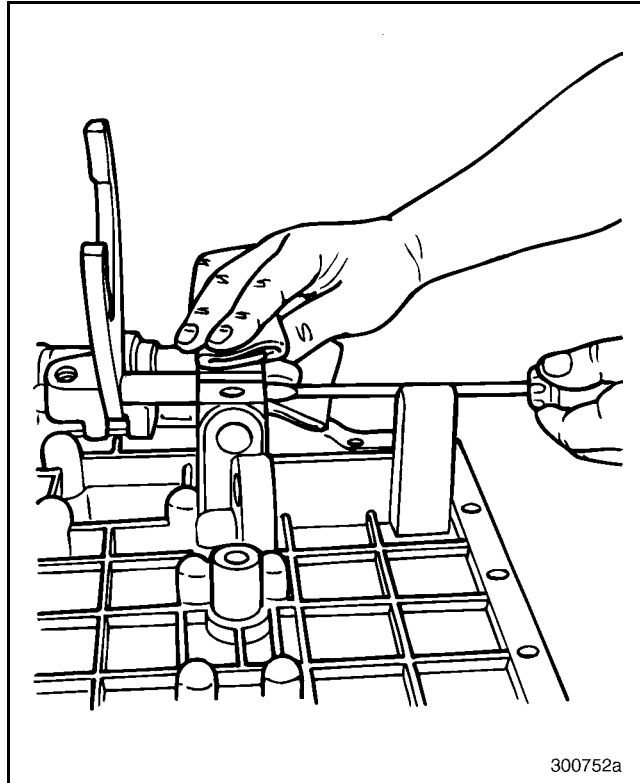

Figure 108 — Pushing Second/Third Shift Rail Forward



REPAIR INSTRUCTIONS

15. Remove the poppet ball and spring from the second/third shift rail vertical pocket in line with the rail.

SERVICE HINT

A magnet is helpful in removing the poppet ball and spring.

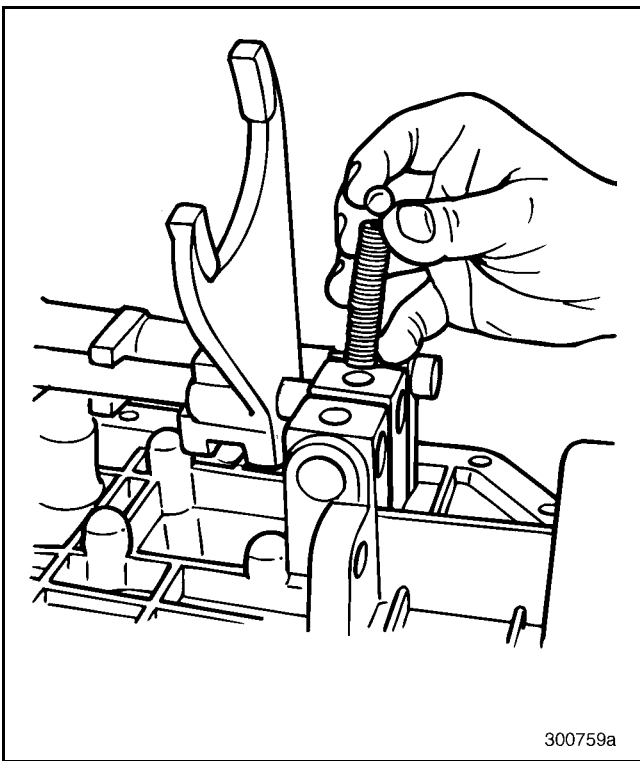

Figure 109 — Removing Poppet Ball and Spring

16. Remove the interlock ball from the horizontal pocket between the second/third shift rail and the fourth/fifth shift rail.

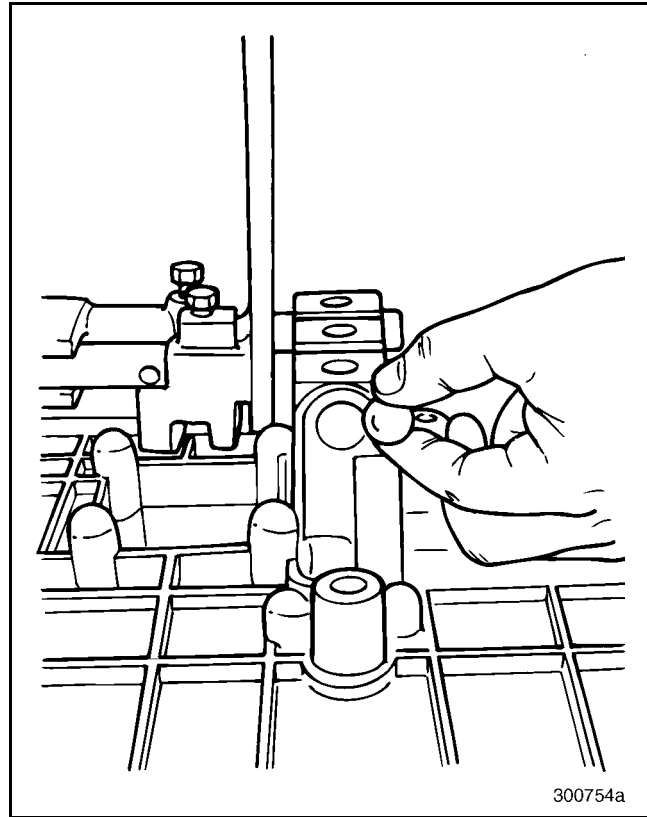

Figure 110 — Removing Interlock Ball



REPAIR INSTRUCTIONS

17. Remove the interlock pin from the second/third shift rail.

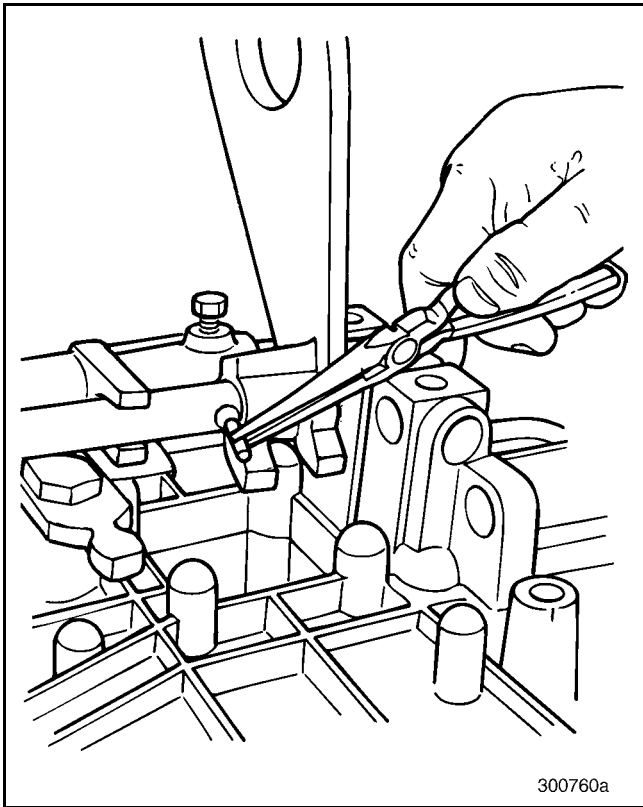

Figure 111 — Removing Pin from Second/Third Shift Rail

18. Slide the second/third shift rail further forward and remove the second/third shift fork.

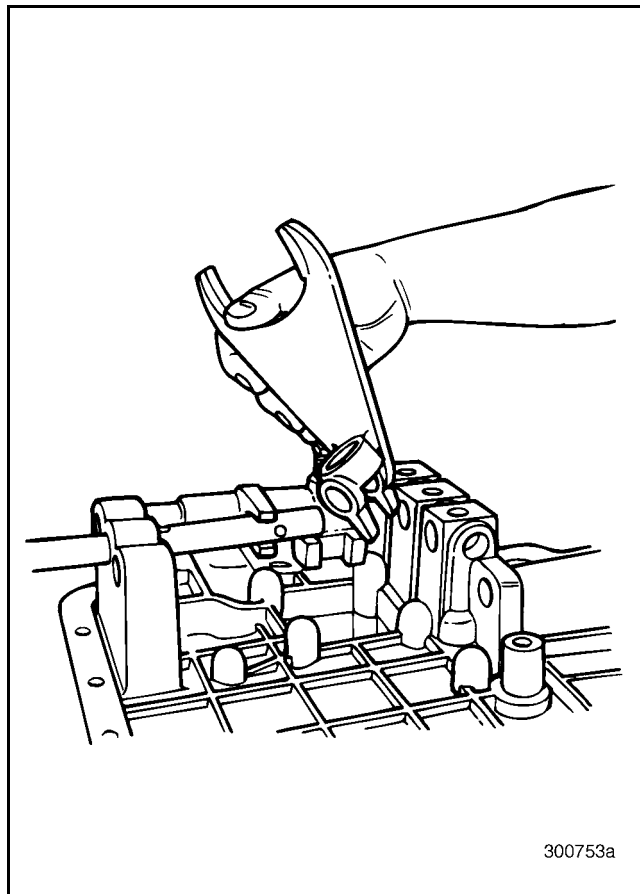

Figure 112 — Removing Second/Third Shift Fork

19. Continue sliding the second/third shift rail until it clears the cover.

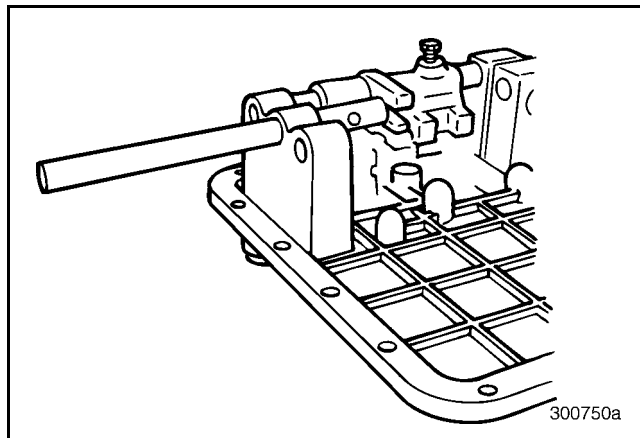

Figure 113 — Removing Second/Third Shift Rail



REPAIR INSTRUCTIONS

20. Remove the setscrew from the fourth/fifth shifter.

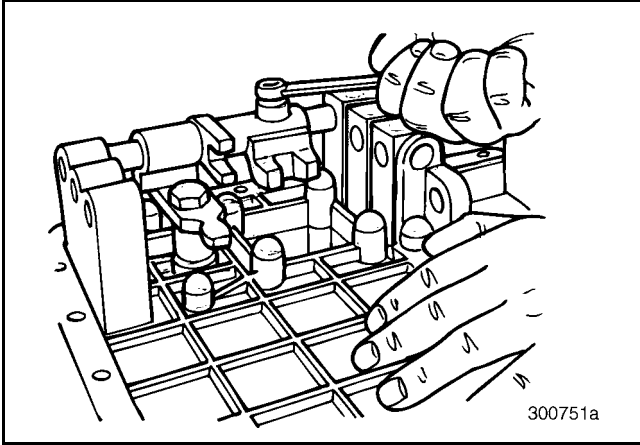

Figure 114 — Removing Setscrew from Fourth/Fifth Shifter

21. Push the fourth/fifth shift rail forward using a metal bar or large screwdriver. Hold a shop towel over the top opening. The shop towel prevents the spring and ball under the rail from popping out and becoming lost.

WARNING

Poppet balls are spring loaded and can cause injury when they are released.

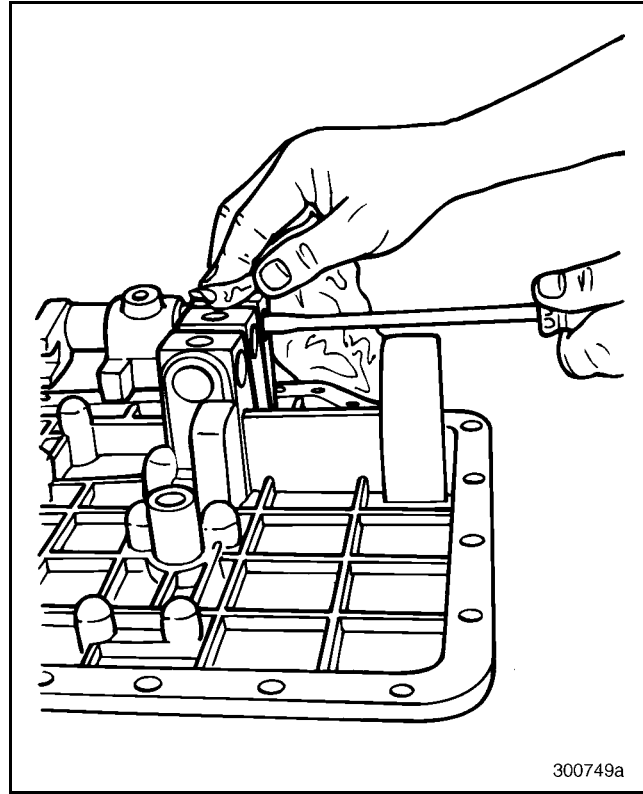

Figure 115 — Pushing Fourth/Fifth Rail Forward

22. Continue sliding the fourth/fifth shift rail forward out of the shift cover. At the same time, remove the fourth/fifth shifter.

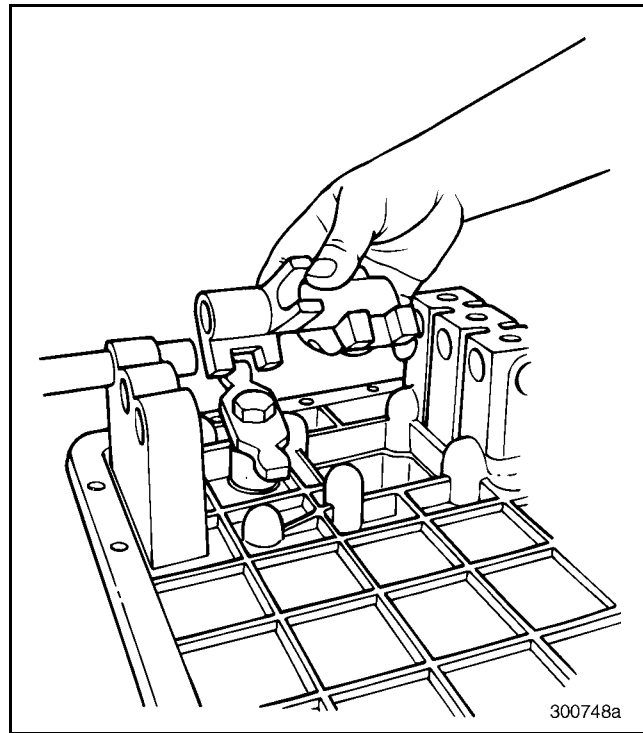

Figure 116 — Removing Fourth/Fifth Shifter



REPAIR INSTRUCTIONS

23. Remove the poppet ball and spring from under the fourth/fifth shift rail.

SERVICE HINT

A magnet is helpful in removing the poppet ball and spring.

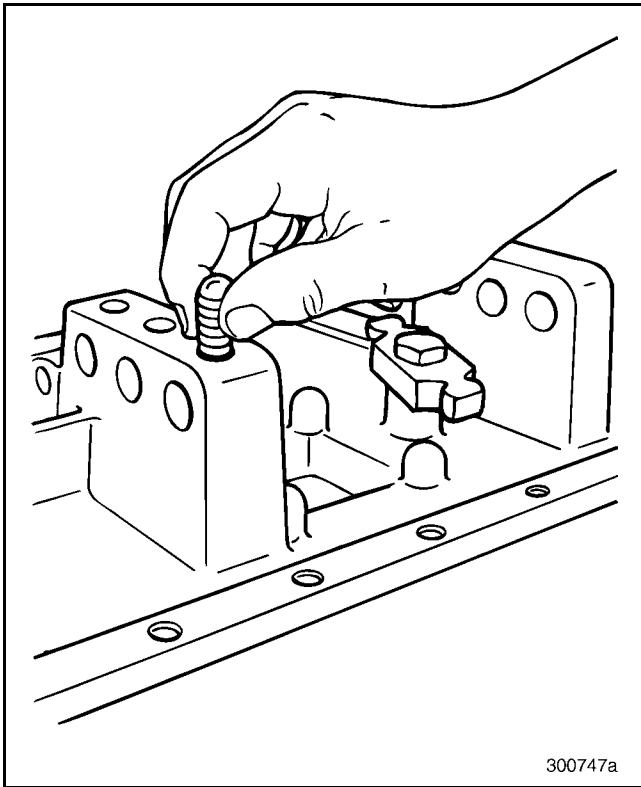

Figure 117 — Removing Poppet Ball and Spring

24. Remove the poppet ball and spring and interlock plunger and spring from the first/reverse shifter.

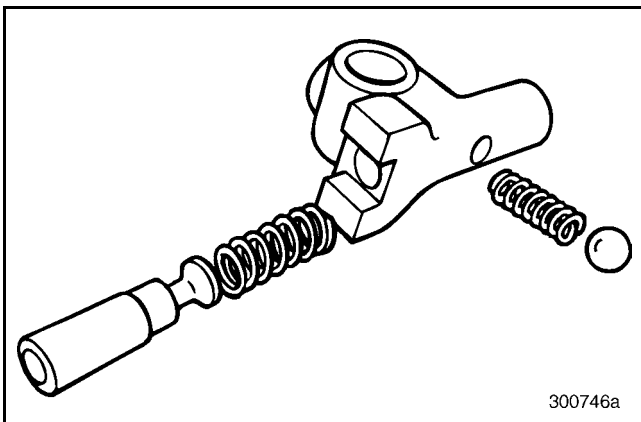

Figure 118 — First/Reverse Shifter Disassembled

25. Remove the reverse light switch from the shift cover.

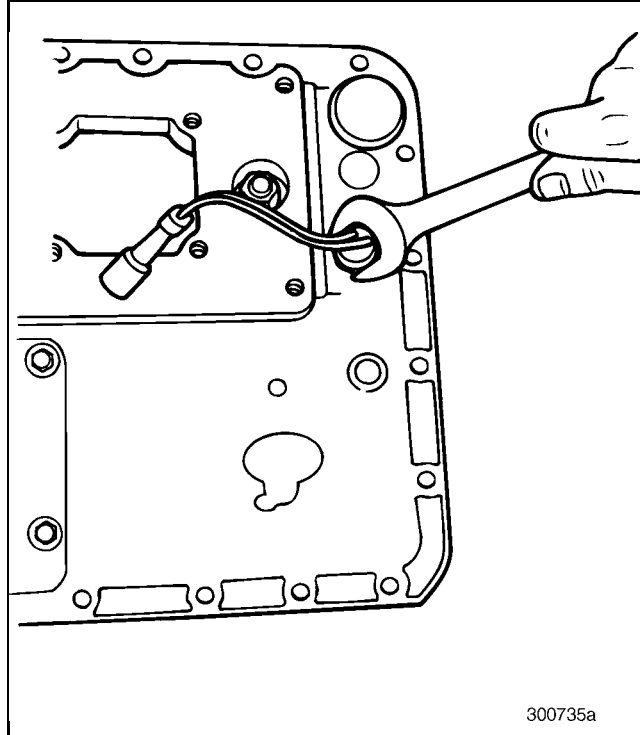

Figure 119 — Removing Reverse Light Switch



REPAIR INSTRUCTIONS

26. Remove the reverse light switch rod.

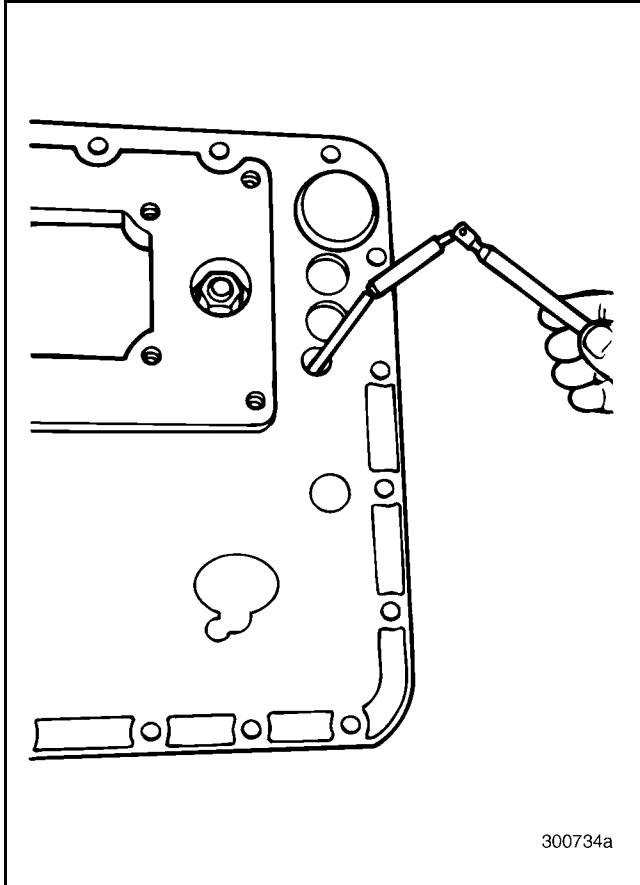

Figure 120 — Removing Reverse Light Switch Rod

27. Remove the nut and washers from the fourth/fifth rocker pin.

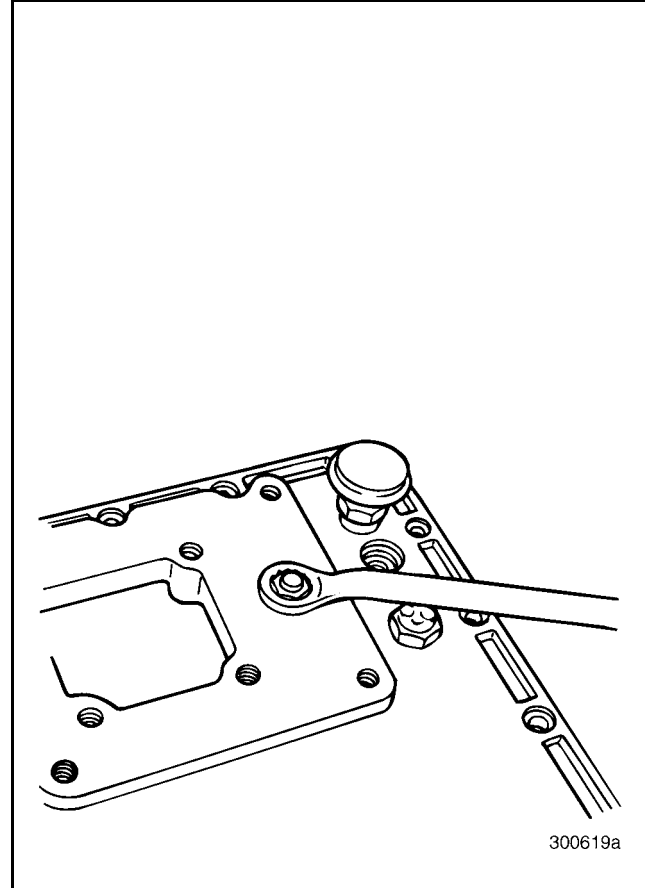

Figure 121 — Loosening Fourth/Fifth Rocker Pin Nut



REPAIR INSTRUCTIONS

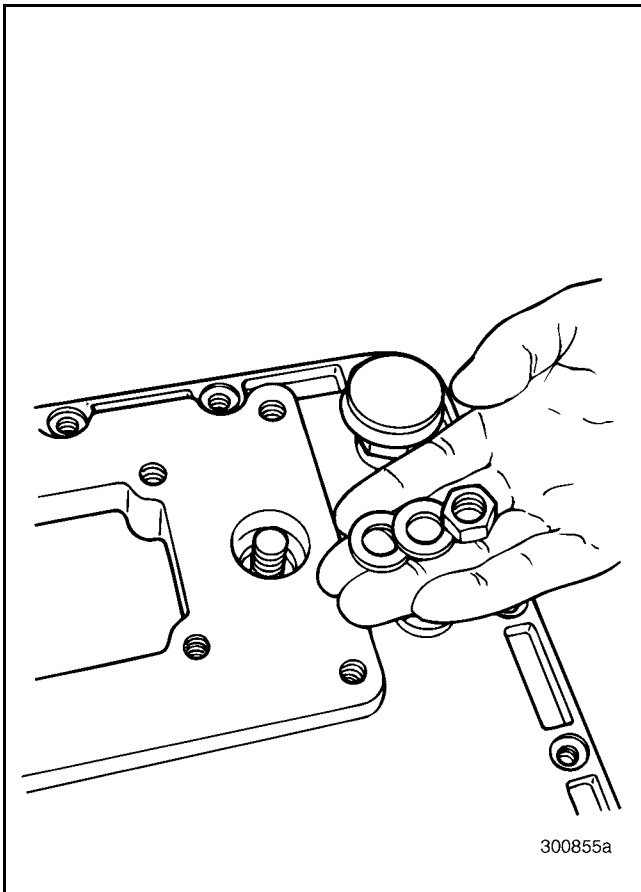

Figure 122 — Recovering the Lock Washer, Flat Washer and Nut

28. Remove the fourth/fifth rocker pin and rocker arm.

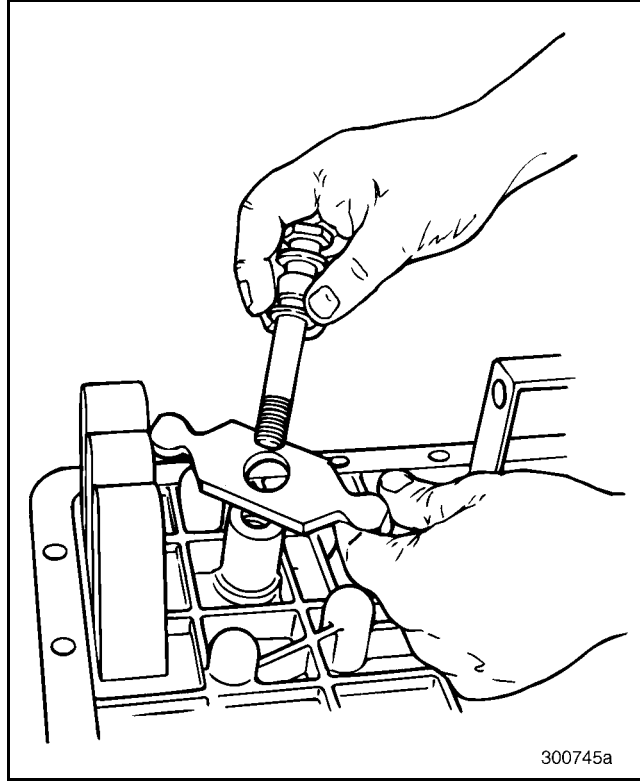

Figure 123 — Removing Fourth/Fifth Rocker Pin and Rocker Arm

29. Remove the shift cover breather vent.

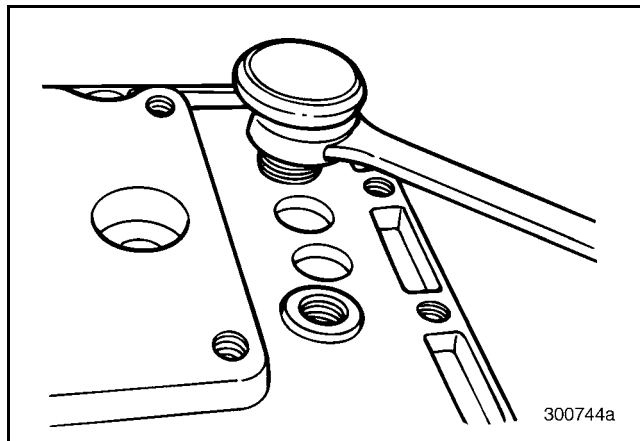

Figure 124 — Removing Breather Vent



REPAIR INSTRUCTIONS

Two-Position Range Shift Cylinder Disassembly [324]

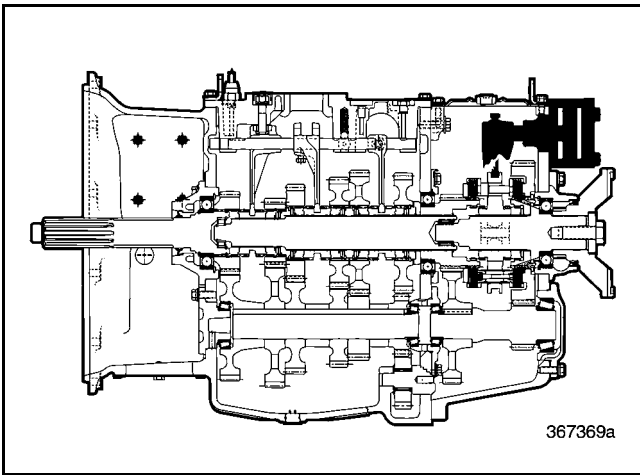

Figure 125 — Range Shift Cylinder Component Locator

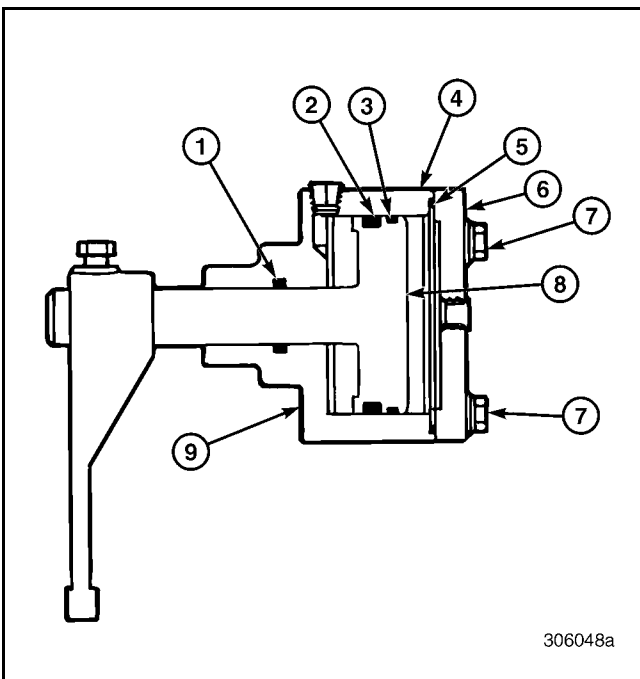

Figure 126 — Cutaway View of Range Shift Cylinder

1. Shift Rail Seal	6. Cylinder Housing Cover
2. Piston Seal	7. Bolt
3. Shift Cylinder Wiper Ring	8. Piston/Shift Rail Assembly
4. Shift Cylinder Housing	9. Gasket
5. Housing-to-Cover O-Ring	

1. With the range shift cylinder in hand, tap the end of the piston shift rail on a firm surface to begin removal of the piston/shift rail assembly.

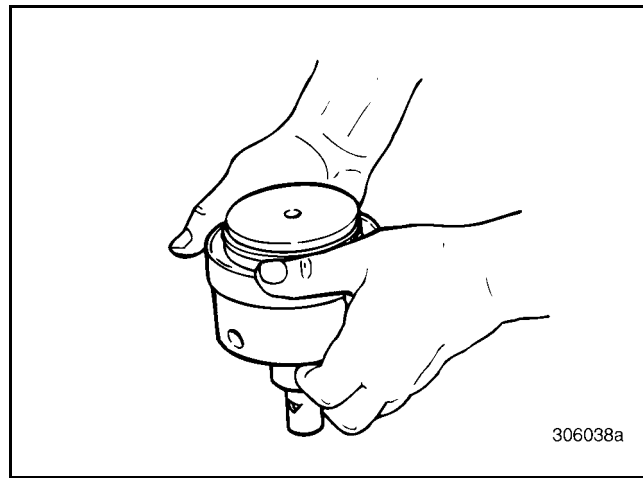

Figure 127 — Piston Assembly Partially Removed

2. Continue moving the piston/shift rail out of the cylinder housing to completely separate the piston/shift rail from the housing. Using a small screwdriver, remove the Teflon® seal and O-ring from the shift rail bore inside the cylinder housing.

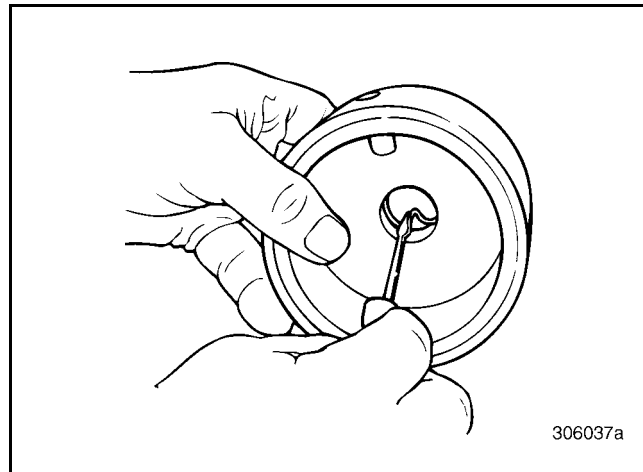

Figure 128 — Removing Teflon® Seal and O-Ring Expander



REPAIR INSTRUCTIONS

3. Remove the wiper ring from the piston groove.

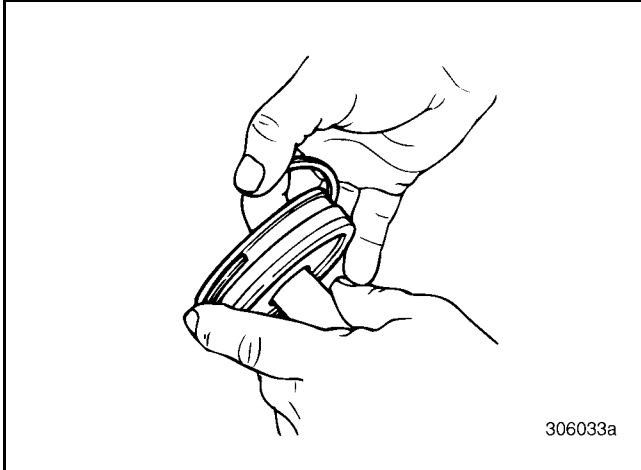

Figure 129 — Removing Wiper Ring from Piston Groove

4. Using a small screwdriver, remove the Teflon® seal and O-ring expander from the second piston groove.

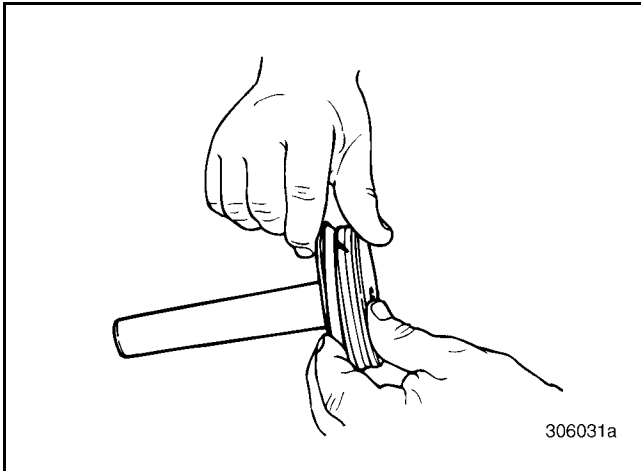

Figure 130 — Removing Teflon® Seal and O-Ring from Piston Grooves

Range Shift Valve [323]

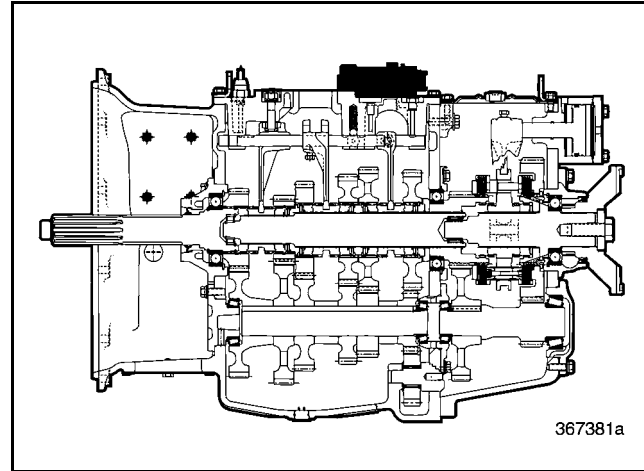

Figure 131 — Range Shift Valve Component Locator

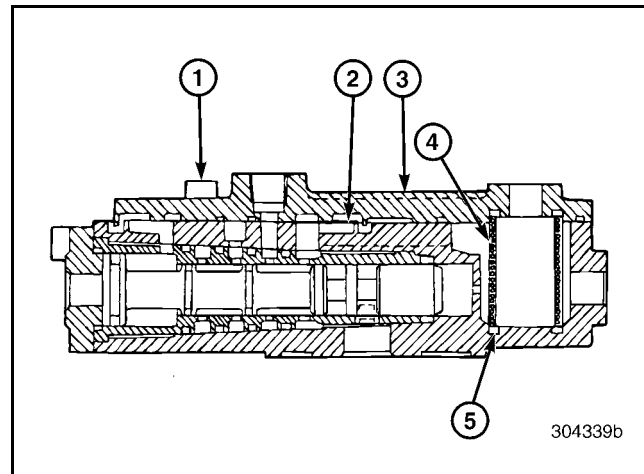

Figure 132 — Exploded View of Range Shift Valve Assembly

- | | |
|-------------------|---------------------------|
| 1. 4 mm Screw | 4. Sintered Bronze Filter |
| 2. Top Cover Seal | 5. Silicon Rubber O-Ring |
| 3. Top Cover | |



REPAIR INSTRUCTIONS

1. Remove the four (4 mm) interlock valve top cover screws.

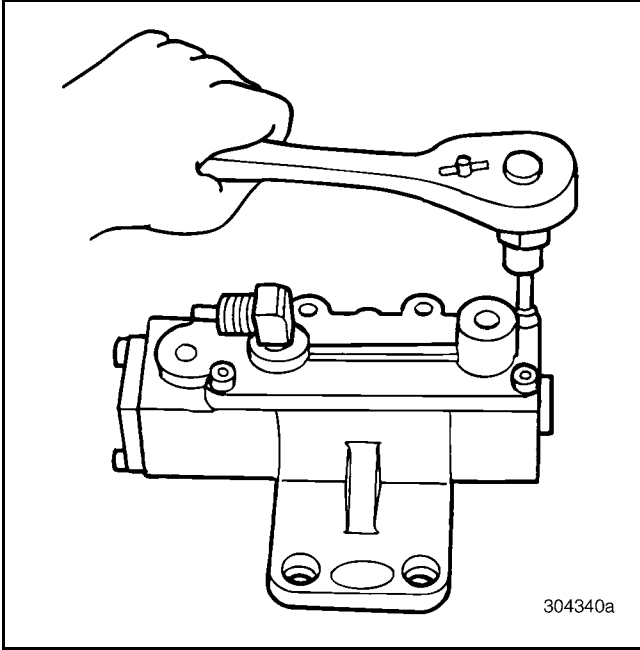

Figure 133 — Range Valve Top Cover Screws

2. Separate cover from valve housing and remove sintered bronze filter and silicone rubber O-ring.

NOTE

The sintered bronze filter is the only part that is serviceable on the range shift valve. Replace the range shift valve as an assembly if any internal component has failed or if the valve has become contaminated.

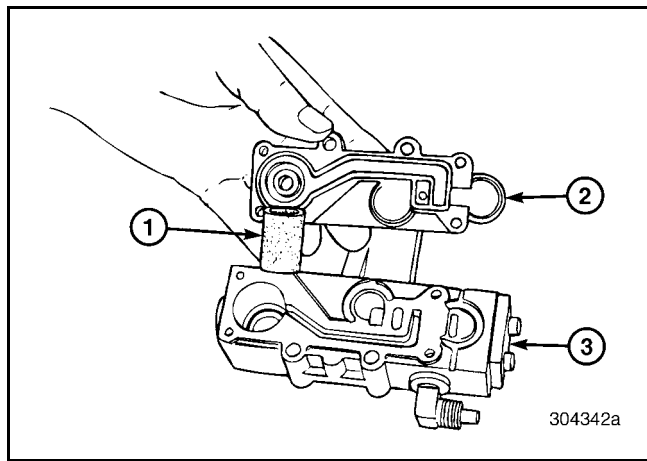

Figure 134 — Removing Sintered Bronze Filter

1. Sintered Bronze Filter
2. Cover

3. Valve Housing

3. Inspect top cover gasket and replace as necessary.



REPAIR INSTRUCTIONS

Main Drive Pinion Disassembly [322]

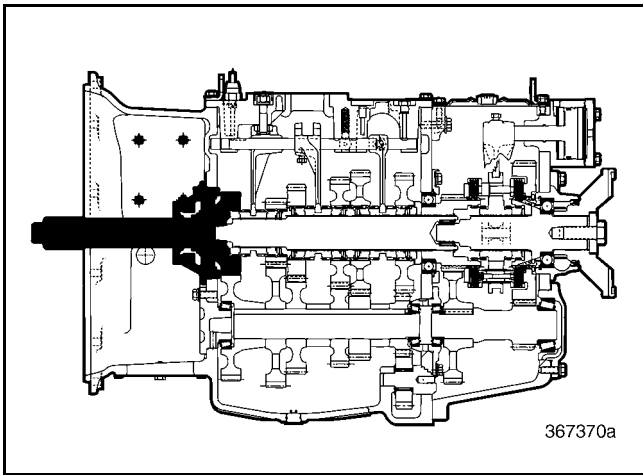

Figure 135 — Main Drive Pinion Component Locator

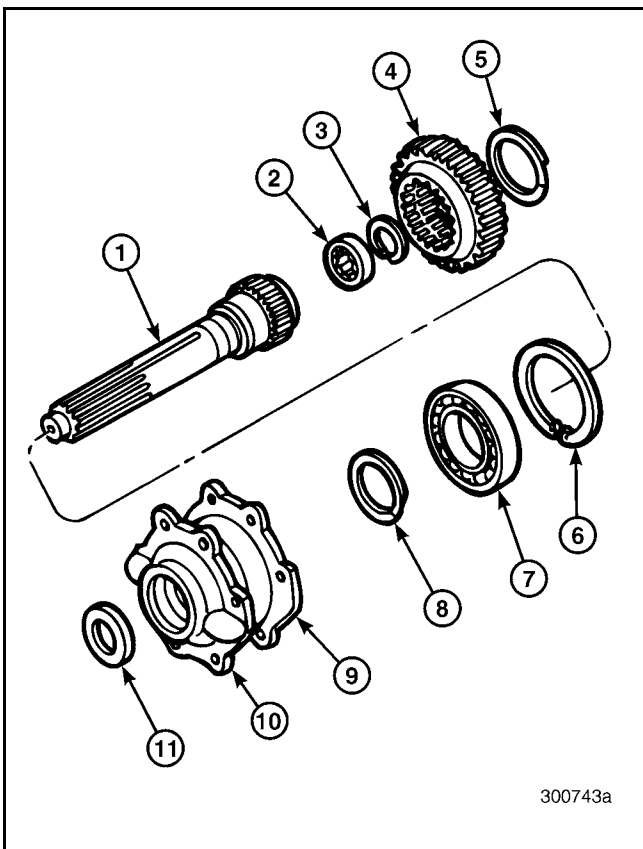

Figure 136 — Exploded View of Main Drive Pinion

1. Main Drive Pinion Shaft	7. Bearing
2. Spigot Bearing	8. Spiral Snap Ring
3. Snap Ring	9. Gasket
4. Main Drive Pinion Gear	10. Pinion Bearing Cover
5. Spiral Snap Ring	11. Oil Seal
6. Snap Ring	

1. Remove the gasket from the main drive pinion bearing cover.

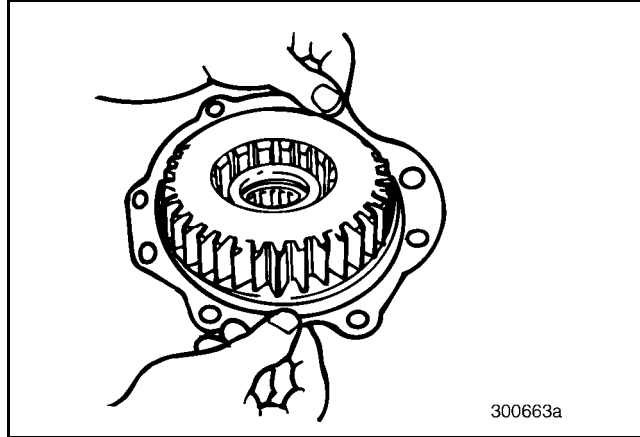

Figure 137 — Removing Gasket from Main Drive Pinion Bearing Cover

2. Remove the spiral snap ring from the end of the main drive pinion shaft, inside the main drive pinion gear. Roll the snap ring out of the groove and over the shoulder of the main drive pinion, using a flat-blade screwdriver.

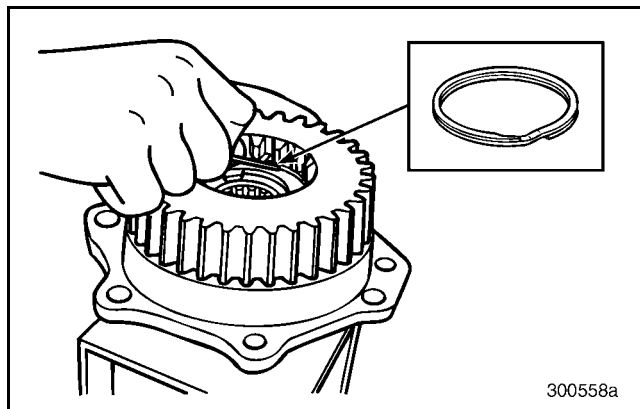

Figure 138 — Removing Snap Ring from Main Drive Pinion

NOTE

The action of removing the snap ring may destroy the snap ring. Make sure a replacement snap ring is available.



REPAIR INSTRUCTIONS

3. Remove the main drive pinion gear by lifting it straight up.

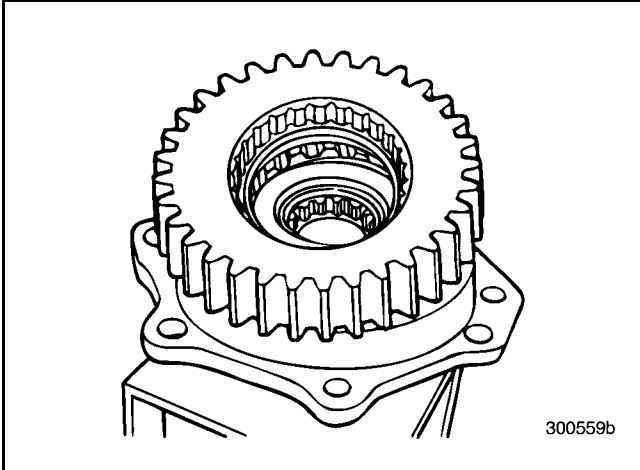

Figure 139 — Main Drive Pinion Gear Removed from Shaft

5. Remove the spigot bearing from inside the end of the main drive pinion shaft.

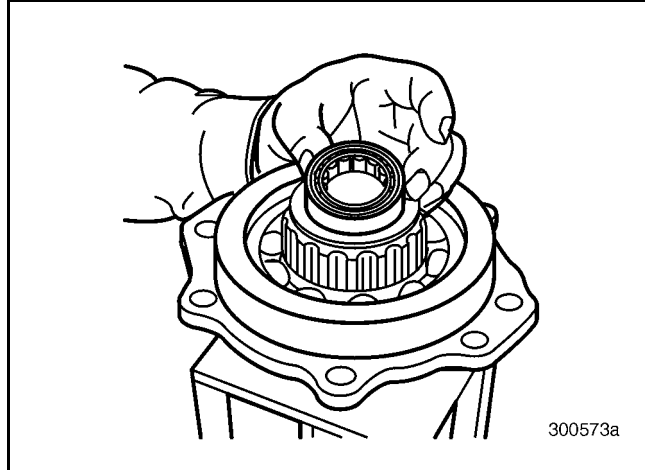

Figure 141 — Spigot Bearing Removed from Main Drive Pinion Shaft

4. Remove the spigot bearing snap ring from the main drive pinion, using suitable snap ring pliers.

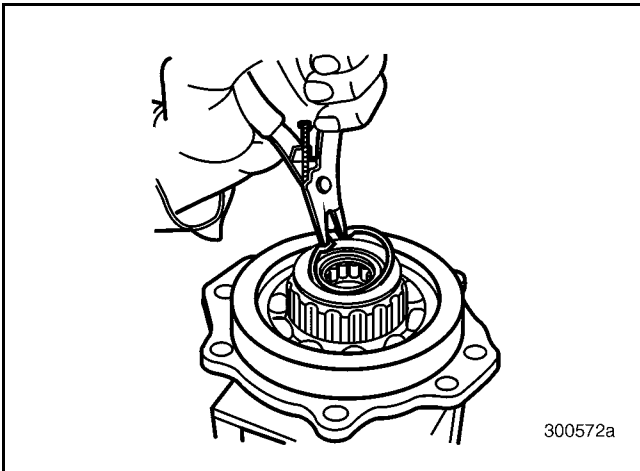

Figure 140 — Removing Spigot Bearing Snap Ring

6. Remove the main drive pinion cover bearing snap ring, using suitable snap ring pliers.

WARNING

The large snap ring is very difficult to compress and remove, and may fly off the snap ring pliers, causing injury.

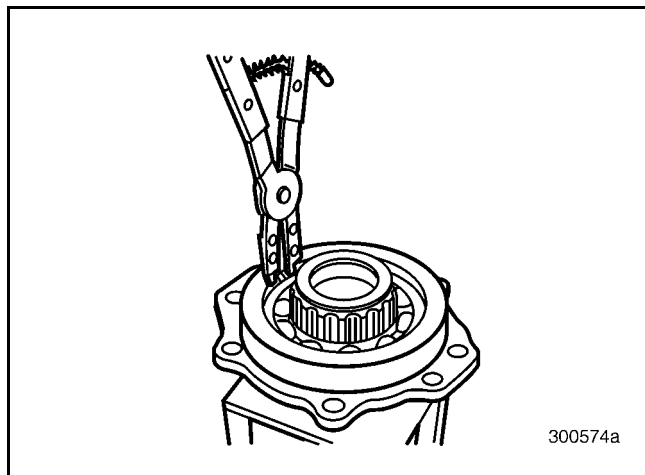

Figure 142 — Removing Main Drive Pinion Cover Bearing Snap Ring



REPAIR INSTRUCTIONS

7. Separate the main drive pinion shaft and bearing assembly from the main drive pinion bearing cover.

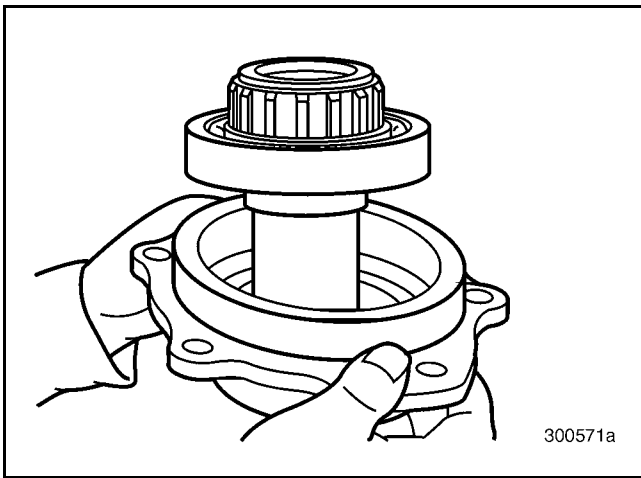

Figure 143 — Removing Main Drive Pinion Shaft and Bearing from Cover

8. Remove the spiral snap ring securing the bearing to the main drive pinion shaft. Using a small flat-blade screwdriver, roll the spiral snap ring out of the groove until released.

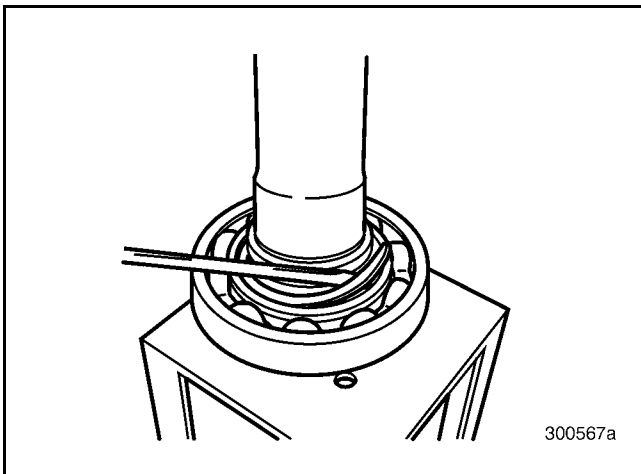

Figure 144 — Removing Spiral Snap Ring from Main Drive Pinion

NOTE

The action of removing the spiral snap ring may destroy the snap ring. Make sure a replacement snap ring is available.

9. Place the main drive pinion shaft and bearing into a suitable press and remove the bearing.

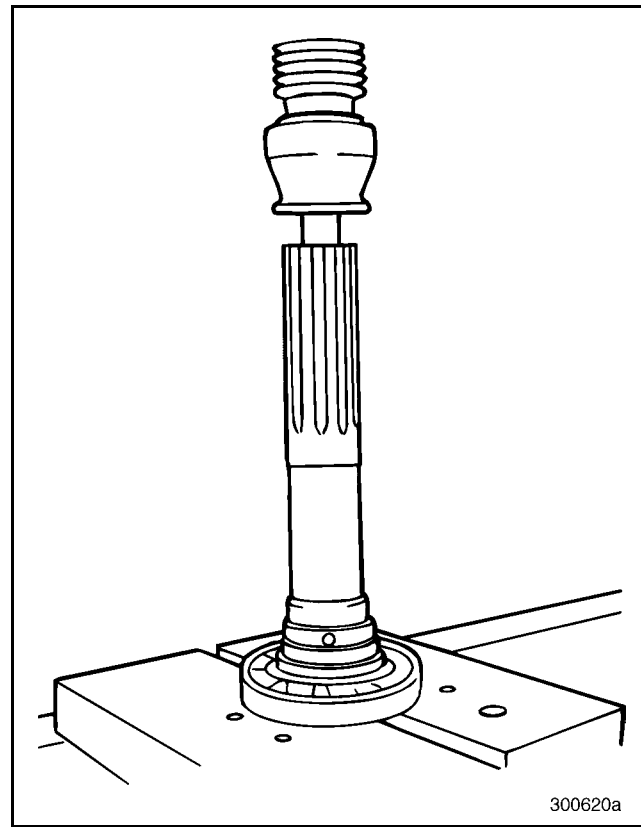

Figure 145 — Pressing Bearing off Main Drive Pinion Shaft



REPAIR INSTRUCTIONS

10. Thoroughly clean the bearing and inspect for damage.
11. Remove the oil seal from the main drive pinion bearing cover, using a hammer and a blunt punch.

NOTE

Removing the oil seal destroys the seal. Make sure a replacement oil seal is available.

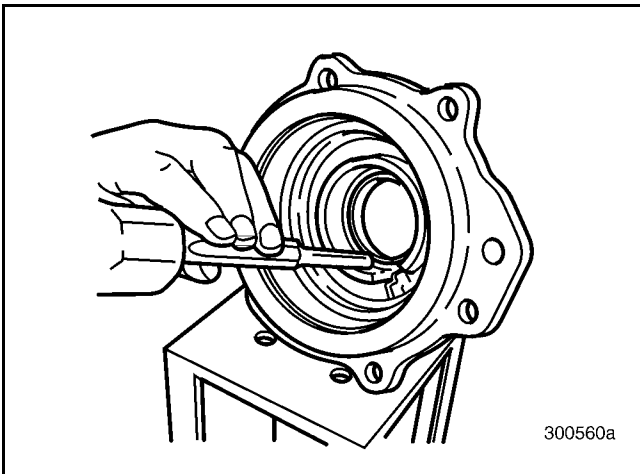

Figure 146 — Removing Bearing Cover Oil Seal

Front Mainshaft Disassembly [322]

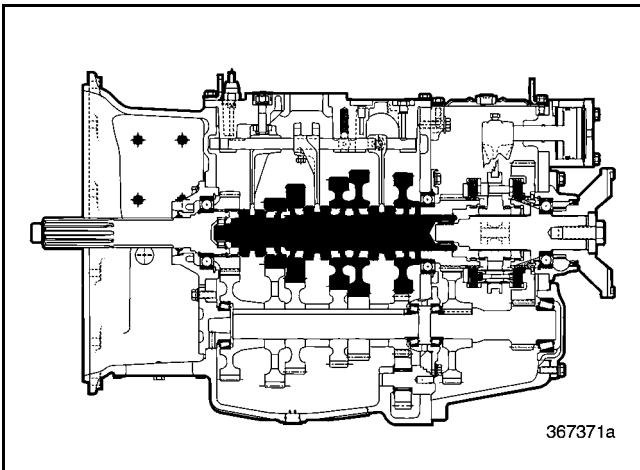

Figure 147 — Front Mainshaft Component Locator

The splines on the mainshaft are usually not aligned for the whole length of the shaft. The recommended procedure is to remove the second, third and fifth speed gears, gear thrust washers and snap rings, and second/third sliding clutch from the front of the shaft (parts shown to the left of the arrows). Remove the remaining reverse and first speed gears and components from the rear of the shaft (parts shown to the right of the arrows).

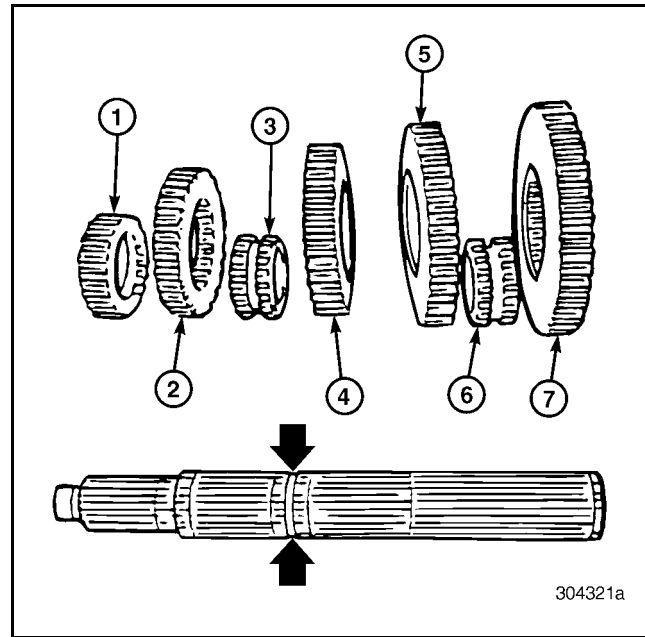
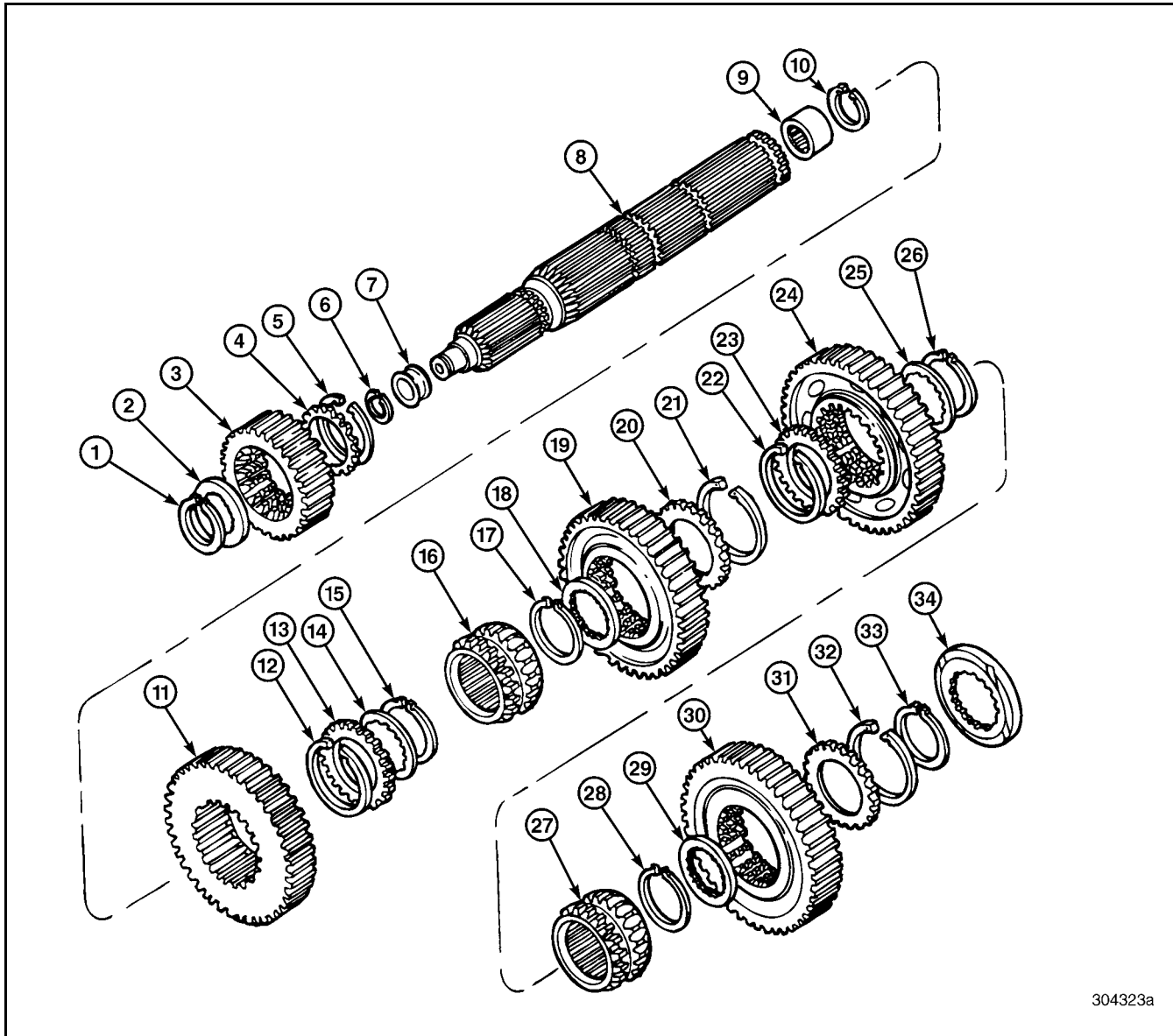

Figure 148 — View of Mainshaft and Gears

- | | |
|-------------------|-------------------|
| 1. 5th/10th Gear | 5. 1st/6th Gear |
| 2. 3rd/8th Gear | 6. Sliding Clutch |
| 3. Sliding Clutch | 7. Reverse Gear |
| 4. 2nd/7th Gear | |



REPAIR INSTRUCTIONS



304323a

Figure 149 — Exploded View of Front Mainshaft

1. Mainshaft Snap Ring	12. Gear Snap Ring	24. First (6th) Speed Gear
2. Internal-Toothed Thrust Washer	13. External-Toothed Thrust Washer	25. Internal-Toothed Thrust Washer
3. Fifth (10th) Speed Gear	14. Internal-Toothed Thrust Washer	26. Mainshaft Snap Ring
4. External-Toothed Thrust Washer	15. Mainshaft Snap Ring	27. Sliding Clutch
5. Gear Snap Ring	16. Sliding Clutch	28. Mainshaft Snap Ring
6. Spigot-Bearing Inner Race Snap Ring	17. Mainshaft Snap Ring	29. Internal-Toothed Thrust Washer
7. Spigot-Bearing Inner Race	18. Internal-Toothed Thrust Washer	30. Reverse Speed Gear
8. Front Mainshaft	19. Second (7th) Speed Gear	31. External-Toothed Thrust Washer
9. Spigot Bearing	20. External-Toothed Thrust Washer	32. Gear Snap Ring
10. Spigot Bearing Snap Ring	21. Gear Snap Ring	33. Mainshaft Snap Ring
11. Third (8th) Speed Gear	22. Gear Snap Ring	34. Spacer
	23. External-Toothed Thrust Washer	



REPAIR INSTRUCTIONS

1. If not already done, remove the reverse speed gear mainshaft snap ring, using suitable snap ring pliers (fifth snap ring groove from the front of the mainshaft).

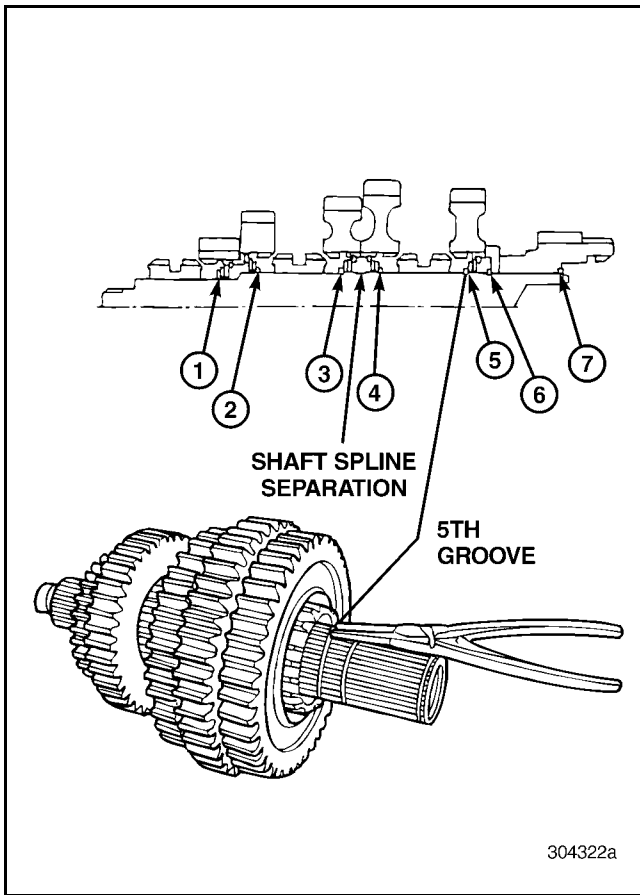

Figure 150 — Removing Reverse Gear Mainshaft Snap Ring

2. Slide the reverse gear off the mainshaft.

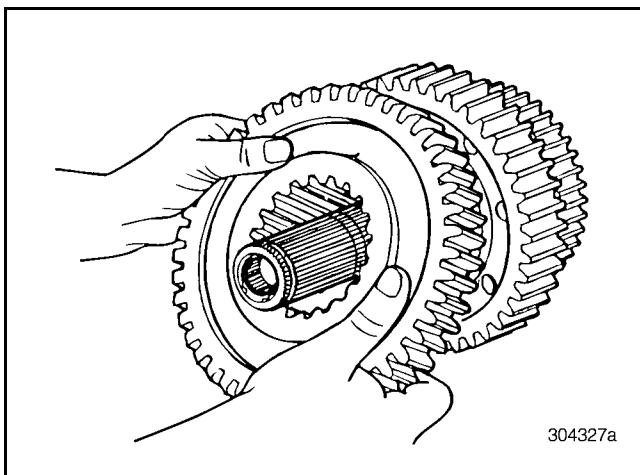

Figure 151 — Removing Reverse Gear from Mainshaft

3. Remove the first/reverse sliding clutch from the mainshaft.

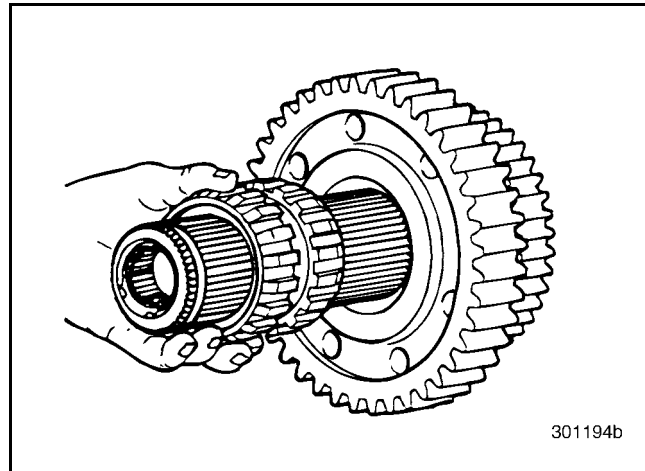

Figure 152 — Removing First/Reverse Sliding Clutch from Mainshaft

4. Using suitable snap ring pliers, remove the snap ring retaining the first (6th) speed gear to the mainshaft (fourth groove from the front of the mainshaft).

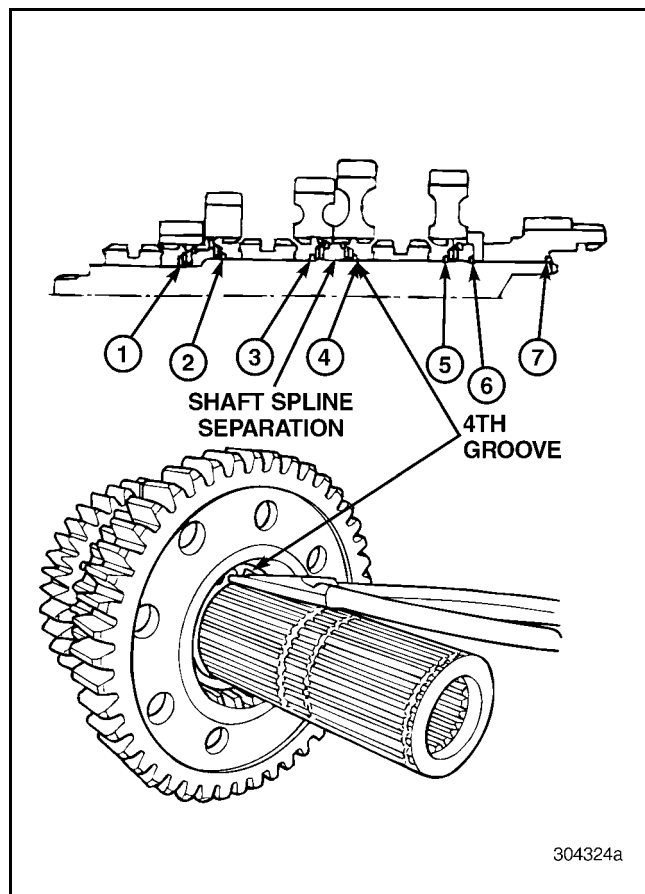

Figure 153 — Removing First Gear Mainshaft Snap Ring



REPAIR INSTRUCTIONS

5. Remove the internal- and external-toothed thrust washers from inside the first (6th) speed gear.

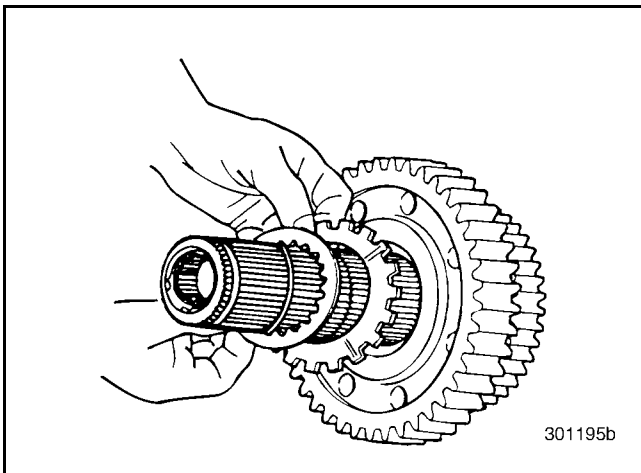

Figure 154 — Removing Internal-Toothed and External-Toothed Thrust Washers

6. Slide first (6th) speed gear from mainshaft.

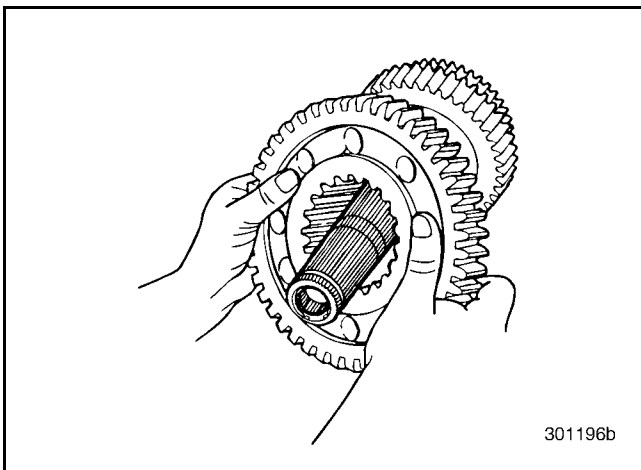

Figure 155 — Removing First Speed Gear

7. Using suitable snap ring pliers, remove the snap ring from the outside groove, inside the first (6th) speed gear.
8. Working at the opposite end of the mainshaft and using suitable snap ring pliers, remove the snap ring that retains the fifth (10th) speed gear to the mainshaft (first groove from the front of the mainshaft).

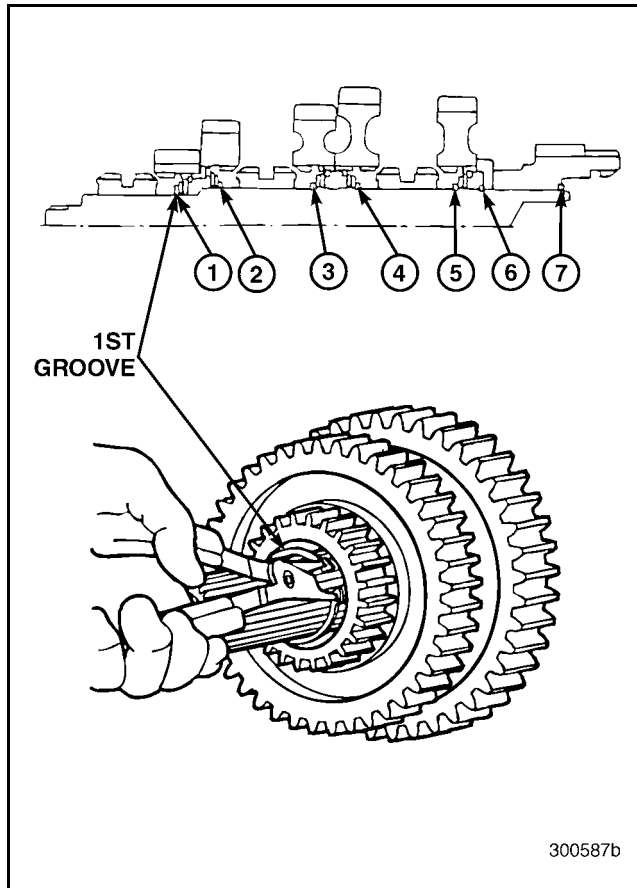

Figure 156 — Removing Fifth Speed Gear Mainshaft Snap Ring

9. Remove the internal- and external-toothed thrust washers and fifth (10th) speed gear from the mainshaft.

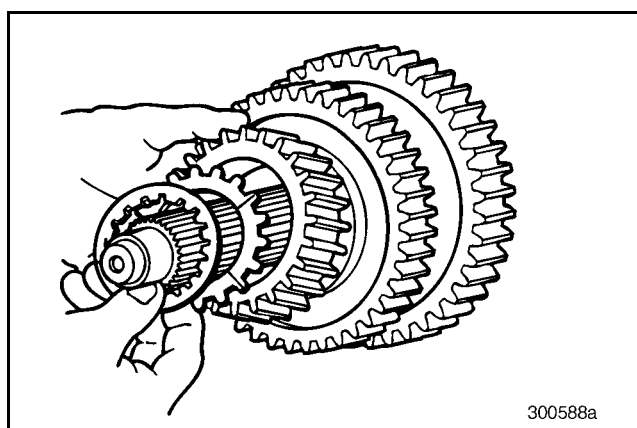

Figure 157 — Removing Internal- and External-Toothed Thrust Washers and Fifth Speed Gear



REPAIR INSTRUCTIONS

10. Remove the snap ring from inside the fifth (10th) speed gear.

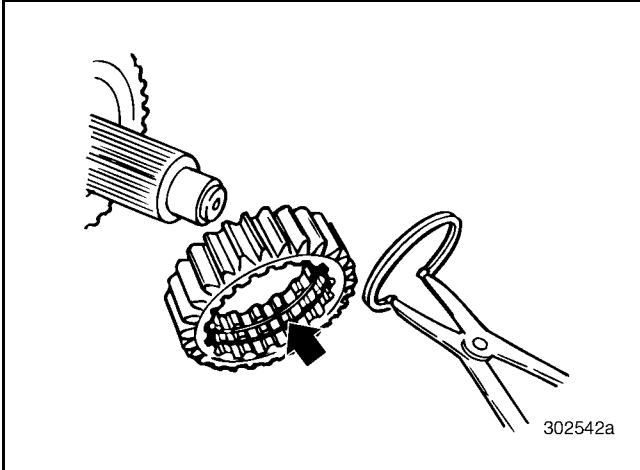

Figure 158 — Removing Snap Ring Inside Fifth Speed Gear

11. Slide the third (8th) speed gear from the mainshaft and remove the snap ring from inside the gear, using suitable snap ring pliers.

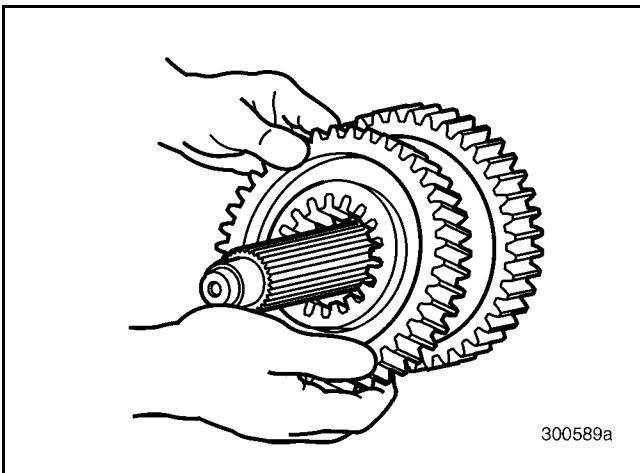

Figure 159 — Removing Third Speed Gear

12. Remove the third (8th) speed gear external- and internal-toothed thrust washers.

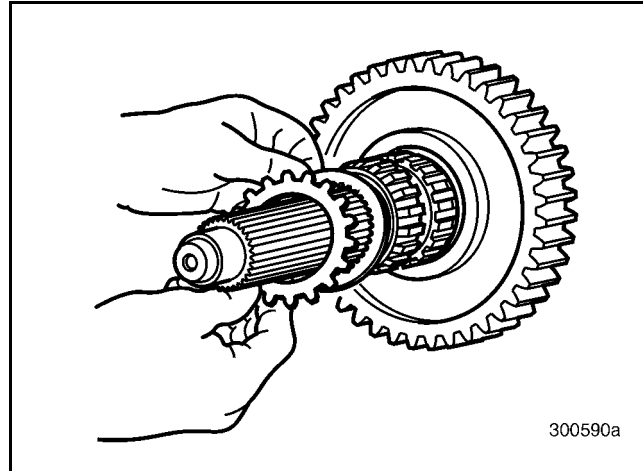

Figure 160 — Removing Third Speed Gear External- and Internal-Toothed Thrust Washers

13. Using suitable snap ring pliers, remove the third (8th) speed gear mainshaft snap ring (second groove from the front of the mainshaft).

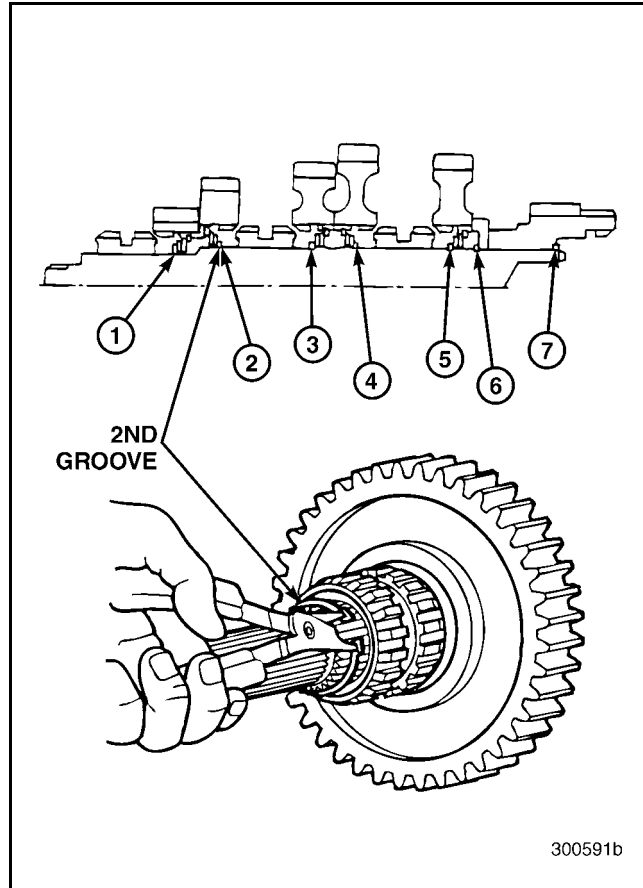

Figure 161 — Removing Third Speed Gear Mainshaft Snap Ring



REPAIR INSTRUCTIONS

14. Remove the second/third sliding clutch from the mainshaft. Slide straight off splines.

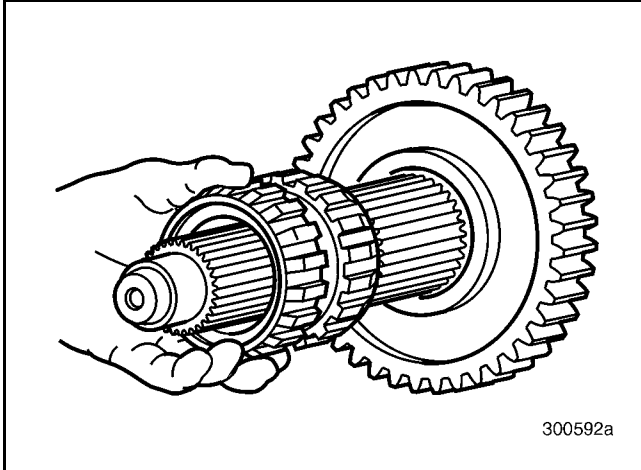

Figure 162 — Removing Second/Third Sliding Clutch

16. Remove the second (7th) speed gear internal- and external-toothed thrust washers.

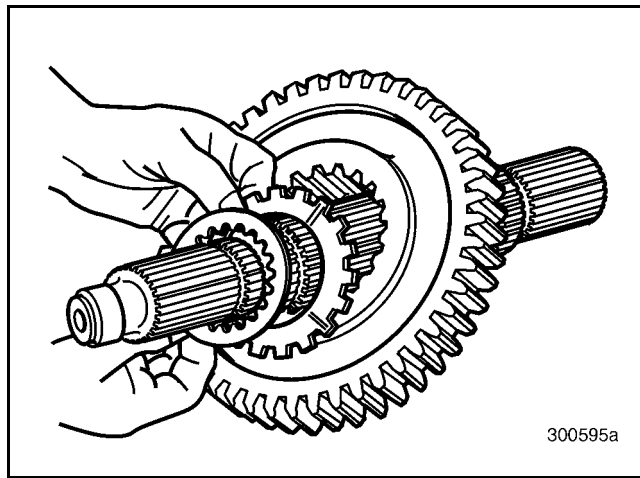

Figure 164 — Removing Internal- and External-Toothed Thrust Washers

15. Using suitable snap ring pliers, remove the second (7th) speed gear mainshaft snap ring (third groove from the front of the mainshaft).

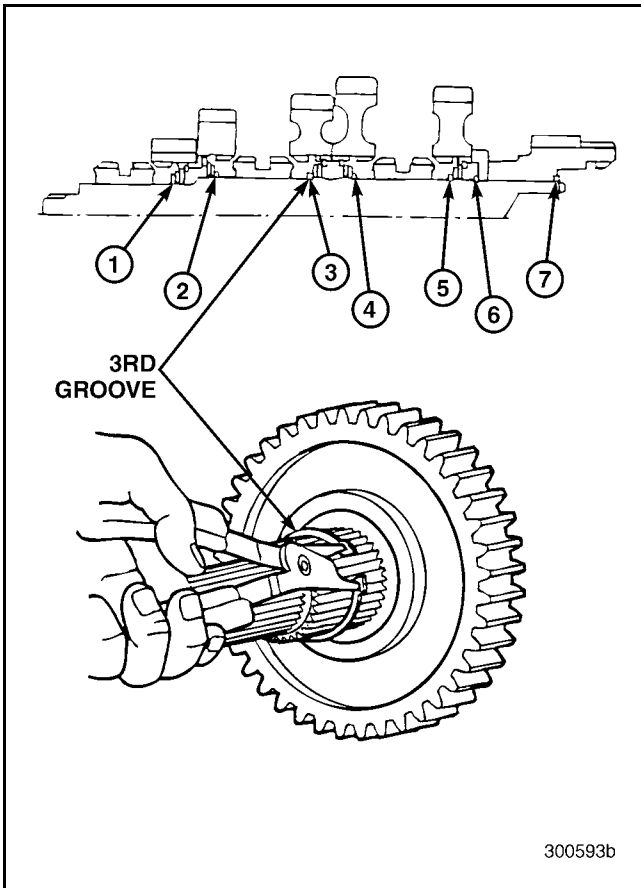

Figure 163 — Removing Second Speed Gear Mainshaft Snap Ring

17. Remove the second (7th) speed gear from the mainshaft. Slide straight off the shaft.

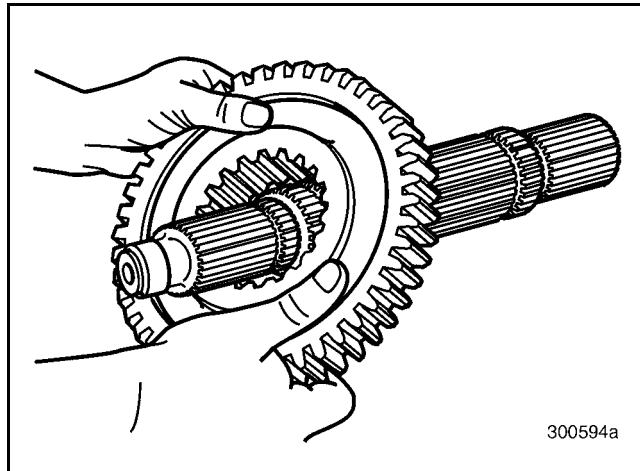

Figure 165 — Removing Second Speed Gear from Mainshaft



REPAIR INSTRUCTIONS

18. Remove the second (7th) speed gear snap ring, using suitable snap ring pliers.

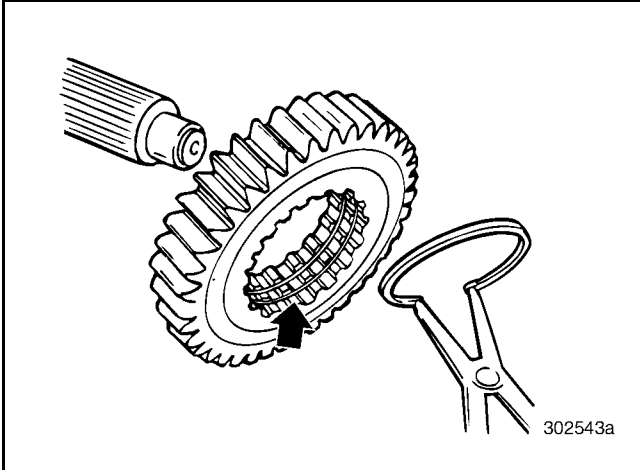

Figure 166 — Removing Second Speed Gear Snap Ring

19. Remove the snap ring that retains the spigot bearing inner race to the mainshaft, using suitable snap ring pliers.

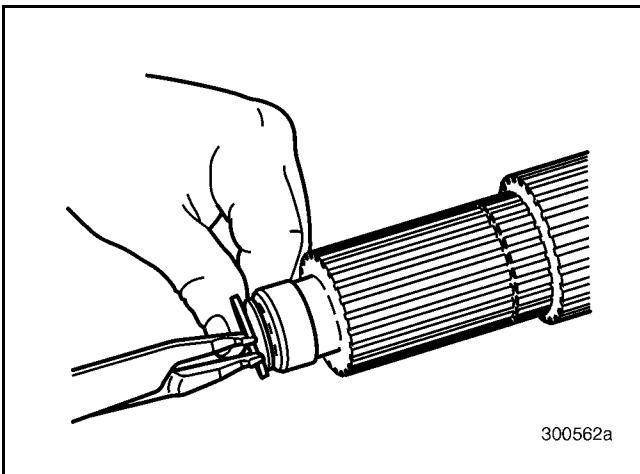

Figure 167 — Removing Spigot Bearing Inner Race Snap Ring

20. Remove the spigot bearing inner race, using a suitable puller.

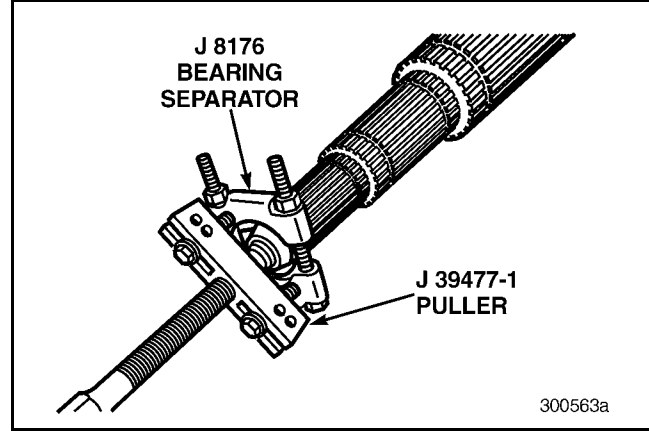

Figure 168 — Removing Spigot Bearing Inner Race

21. If inspection reveals the need to remove and replace the spigot bearing (rear end of shaft), first remove the snap ring and then the bearing.

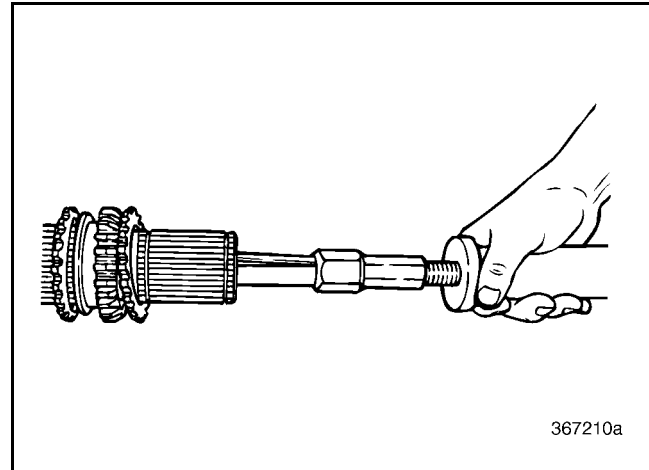

Figure 169 — Removing Front Mainshaft Rear Spigot Bearing



REPAIR INSTRUCTIONS

Rear Mainshaft and Synchronizer Disassembly [322]

1. Remove the synchronizer assembly from the rear mainshaft.

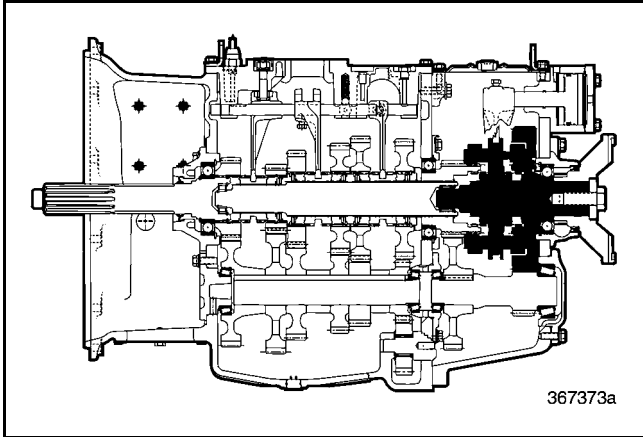

Figure 170 — Rear Mainshaft and Synchronizer Component Locator

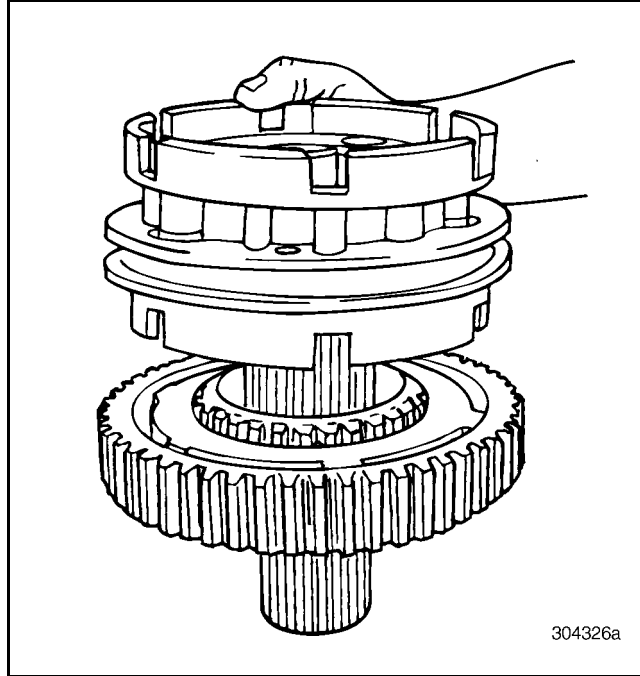

Figure 172 — Removing Synchronizer Assembly

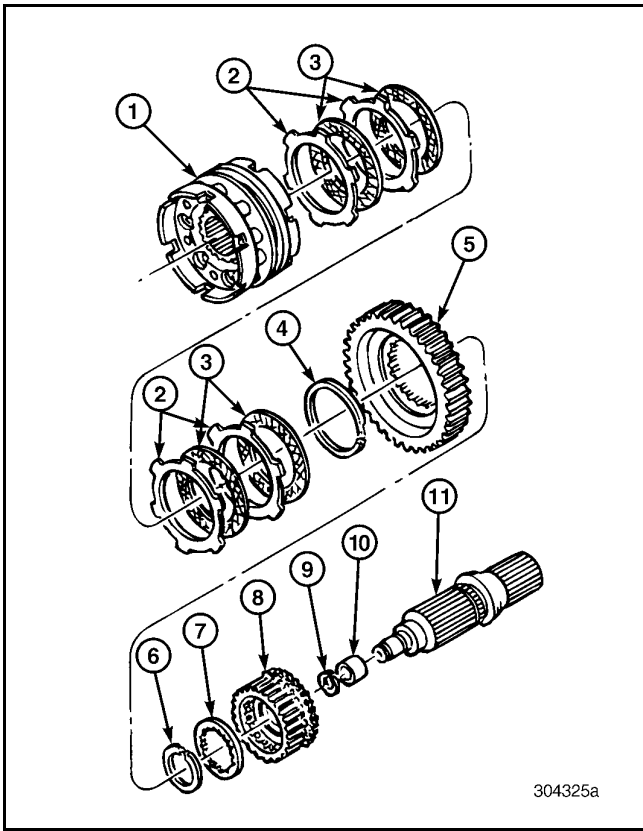

Figure 171 — Exploded View of Rear Mainshaft and Synchronizer Assembly

1. Synchronizer Assembly	7. Internal-Toothed Thrust Washer
2. Reaction Discs	8. Lo-Range Gear Hub
3. Friction Discs	9. Snap Ring
4. Snap Ring	10. Spigot Bearing Inner Race
5. Lo-Range Gear	11. Rear Mainshaft
6. Snap Ring	

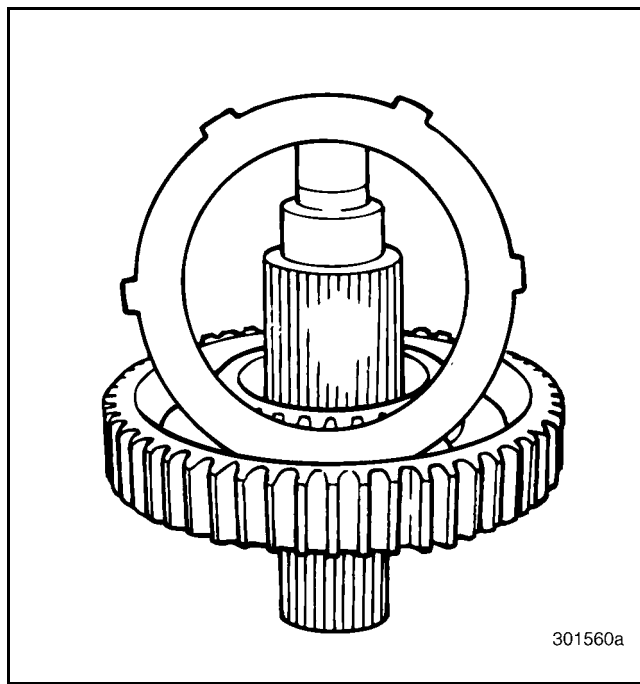

Figure 173 — Removing Reaction Disc



REPAIR INSTRUCTIONS

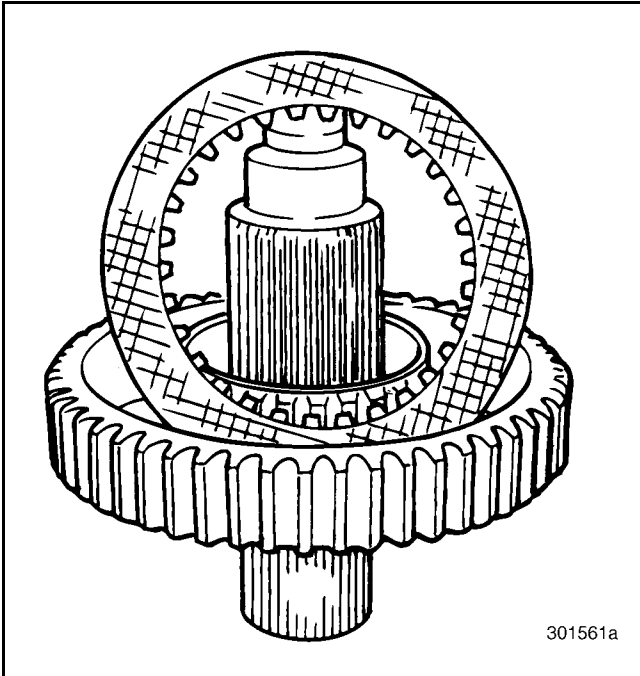

Figure 174 — Removing Friction Disc

3. Remove the spiral snap ring securing the Lo-range gear to the Lo-range gear hub and then remove the Lo-range gear.

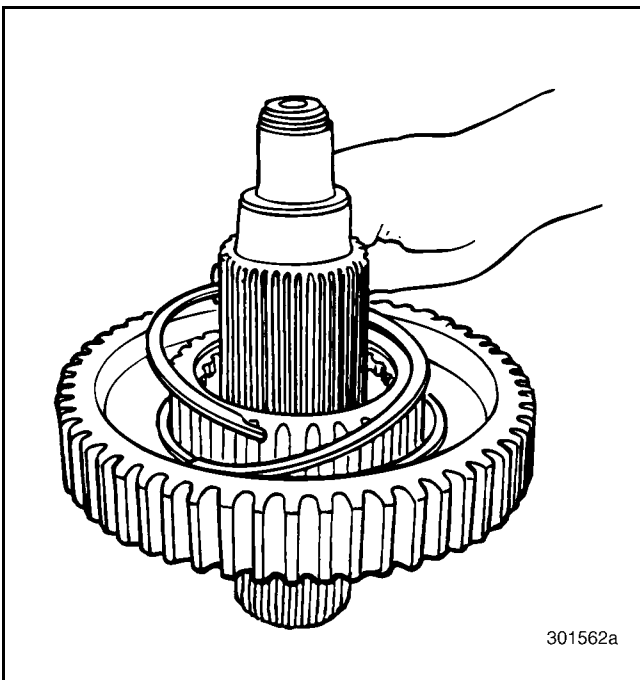

Figure 175 — Removing Lo-Range Gear Snap Ring

4. Remove the snap ring from inside the Lo-range gear hub.

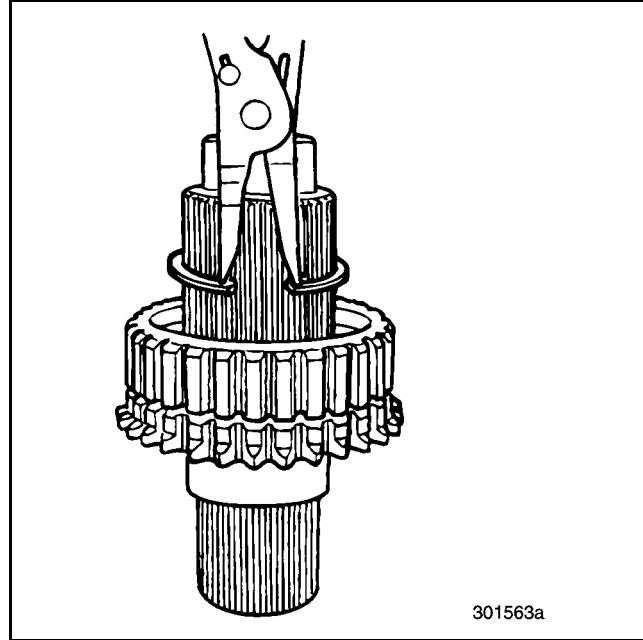

Figure 176 — Removing Gear Hub Snap Ring

5. Remove the gear hub thrust washer from the rear mainshaft.

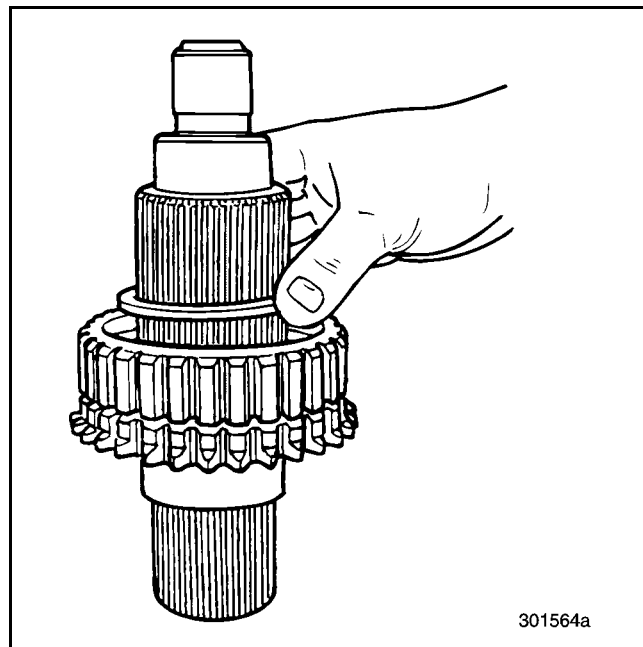

Figure 177 — Removing Thrust Washer



REPAIR INSTRUCTIONS

6. Remove the Lo-range gear hub from the rear mainshaft.

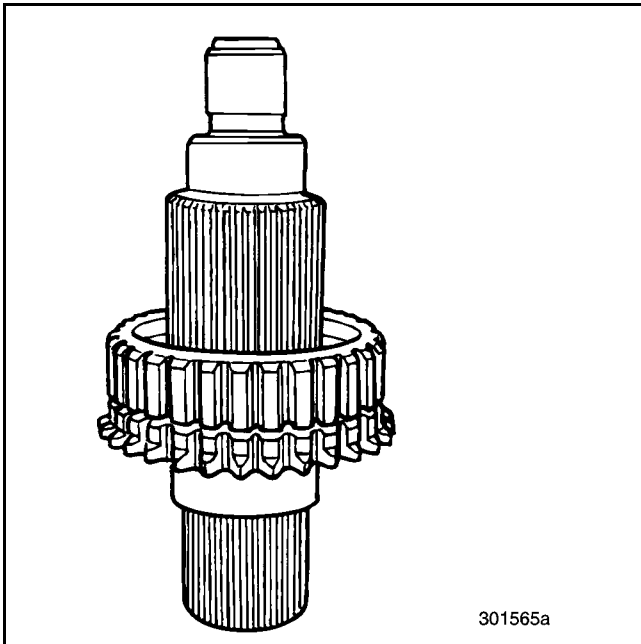

Figure 178 — Removing Lo-Range Gear Hub

7. Remove the spigot bearing inner race snap ring from the front of the rear mainshaft.

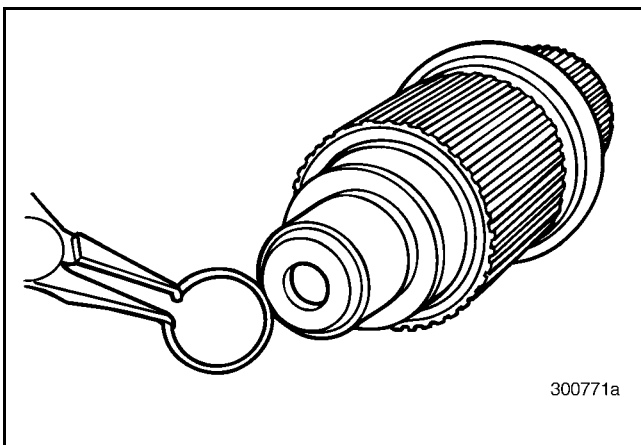

Figure 179 — Removing Snap Ring

8. Press the spigot bearing inner race off the front end of the rear mainshaft using bearing separator J 22912-01 or equivalent.

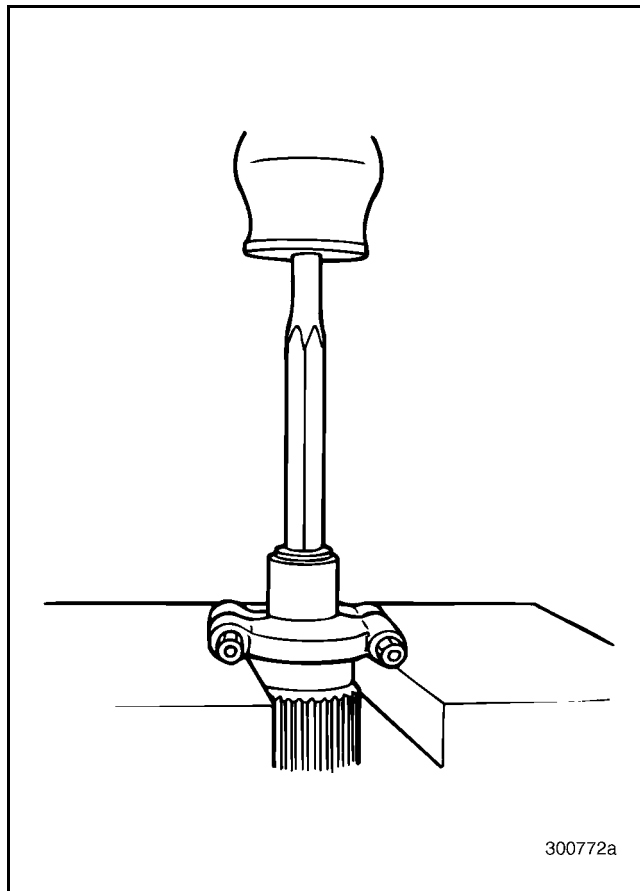

Figure 180 — Removing Snap Ring



REPAIR INSTRUCTIONS

Synchronizer Disassembly [322]

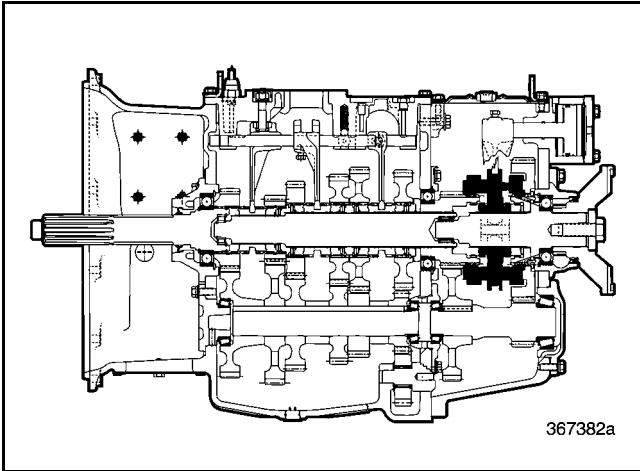

Figure 181 — Synchronizer Assembly Component Locator

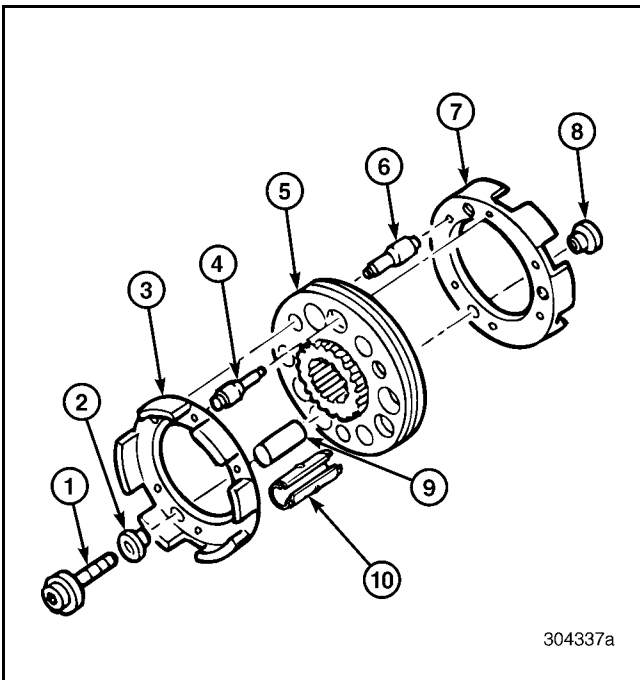

Figure 182 — Exploded View of Synchronizer

1. 12-Point Screw	6. Synchronizer Pin
2. Nonthreaded Insert	7. Clutch Housing
3. Clutch Housing	8. Threaded Insert
4. Synchronizer Pin	9. Support Tube
5. Sliding Clutch	10. Preload Spring

1. Remove the 12-point screws and threaded and nonthreaded inserts from the synchronizer assembly.

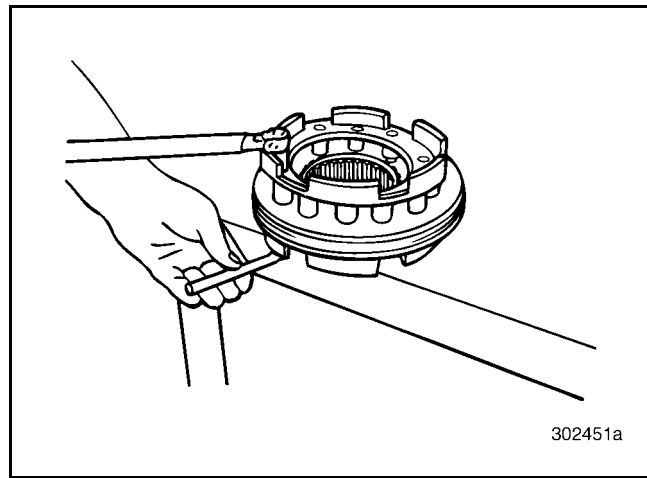

Figure 183 — Removing 12-Point Screws

2. Remove the clutch housing from the assembly.
3. Remove the three support tubes and preload springs from the synchronizer assembly.

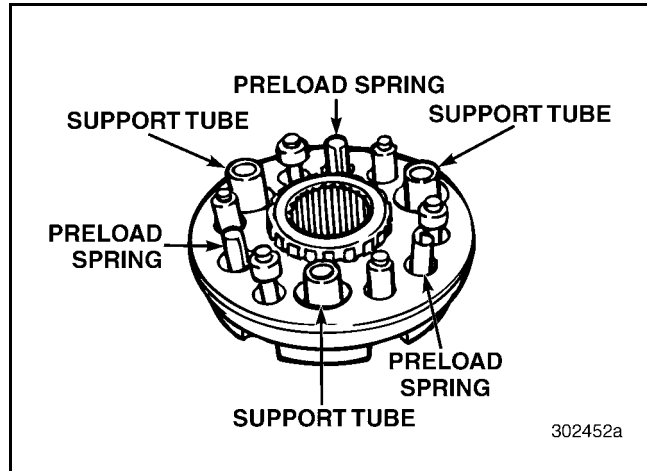

Figure 184 — Remove Synchronizer Support Tubes and Preload Springs



REPAIR INSTRUCTIONS

4. Remove the sliding clutch from the remaining clutch housing.

NOTE

As you remove the synchronizer sliding clutch and pins, notice that the pins and the sliding clutch are marked with the letter "R", which stands for "Rear." All the R marks on either end of the pins are placed on the same side of the sliding clutch marked with the letter R. During reassembly, make sure to coordinate all R marks on both the pins and sliding clutch of the synchronizer assembly. All R marks must face the rear of the transmission when installed.

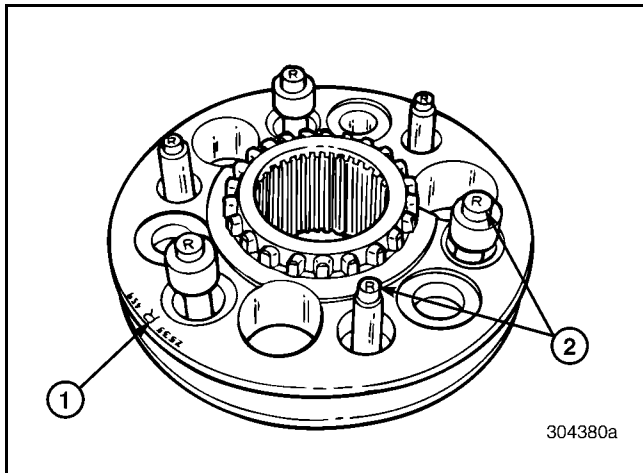

Figure 185 — Letter "R" on Sliding Clutch and Synchronizer Pins

- | | |
|--|---|
| 1. "R" on Sliding Clutch, Faces Rearward | 2. "R" on Synchronizer Pins, Faces Rearward |
|--|---|

5. Remove the synchronizer pins from the remaining clutch housing.

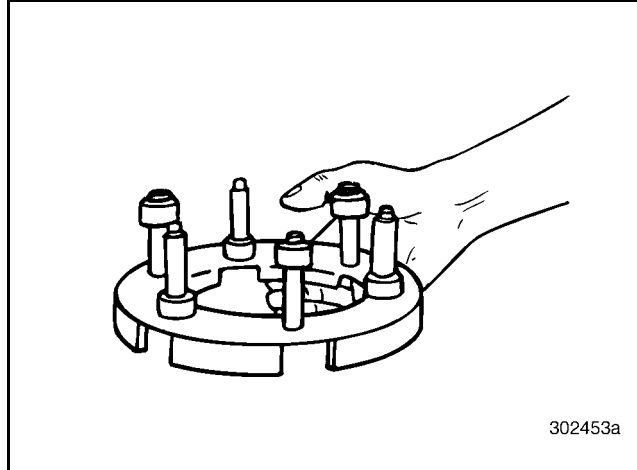

Figure 186 — Removing Synchronizer Pins

6. Thoroughly clean the synchronizer assembly and inspect for damage.



REPAIR INSTRUCTIONS

Rear Mainshaft Bearing Cover Disassembly [321]

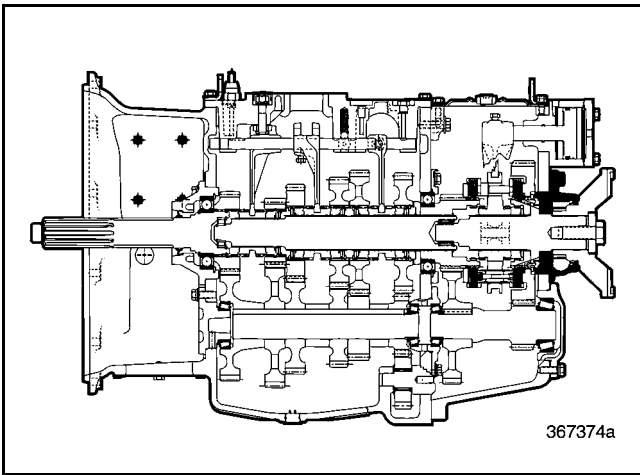

Figure 187 — Rear Mainshaft Bearing Component Locator

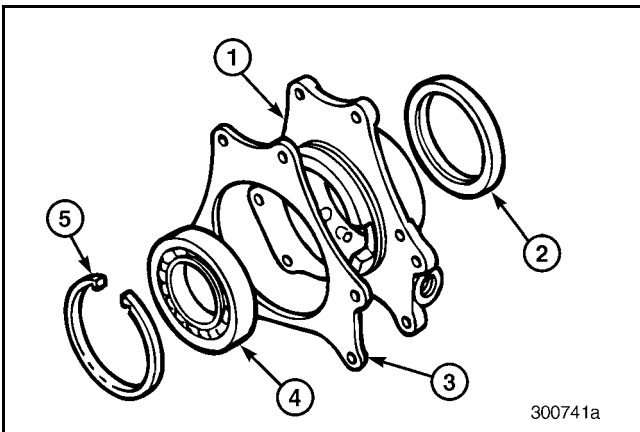

Figure 188 — Exploded View of Rear Mainshaft Bearing Cover

1. Bearing Cover	4. Bearing
2. Oil Seal	5. Snap Ring
3. Gasket	

1. Remove the gasket from the bearing cover.
2. Remove the snap ring securing the bearing in the rear mainshaft bearing cover, using suitable snap ring pliers.

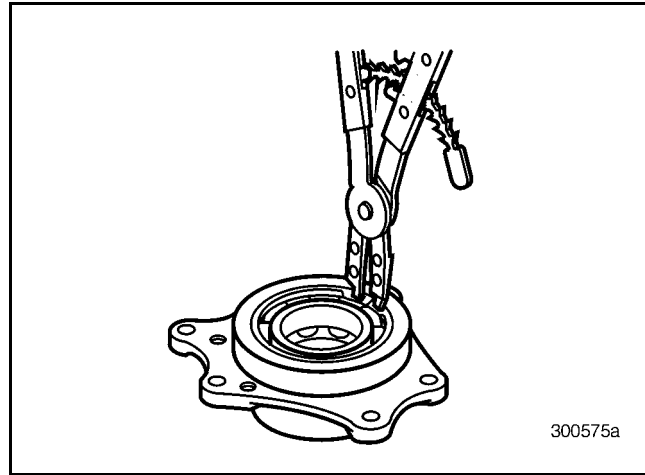

Figure 189 — Removing Snap Ring from Rear Mainshaft Bearing Cover

3. Remove the bearing from the rear mainshaft bearing cover, using a suitable puller.

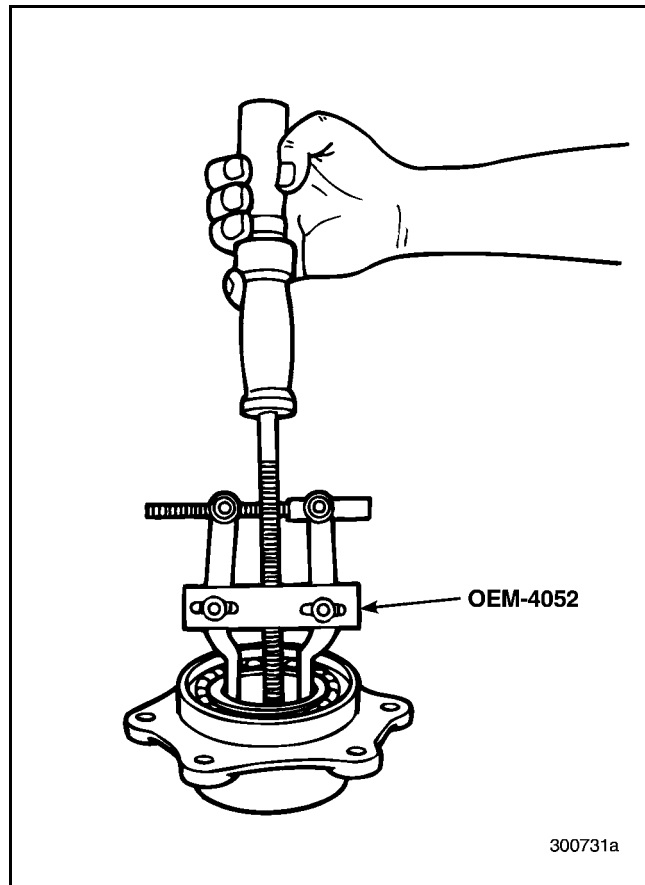

Figure 190 — Removing Bearing from Bearing Cover



REPAIR INSTRUCTIONS

- Remove the oil seal from the rear mainshaft bearing cover, using a hammer and blunt punch. Drive the seal out from the opposite side. Discard the cover gasket.

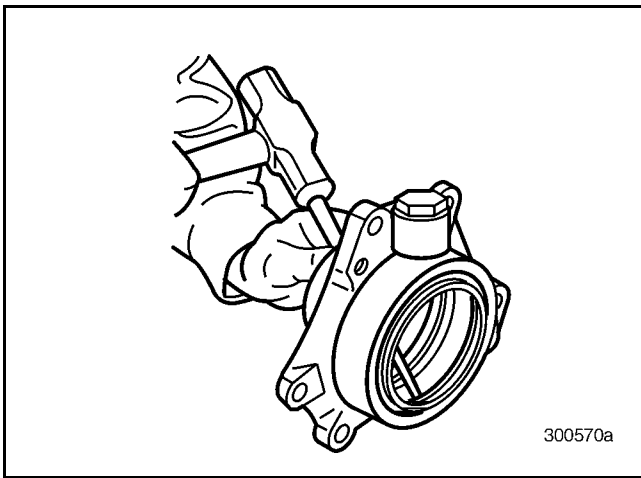

Figure 191 — Using Hammer and Blunt Punch to Remove Oil Seal

NOTE

This action destroys the oil seal. Make sure a replacement oil seal is readily available.

- Thoroughly clean the rear mainshaft bearing and bearing cover, and inspect for damage.

Compound Main Drive Gear Disassembly [322]

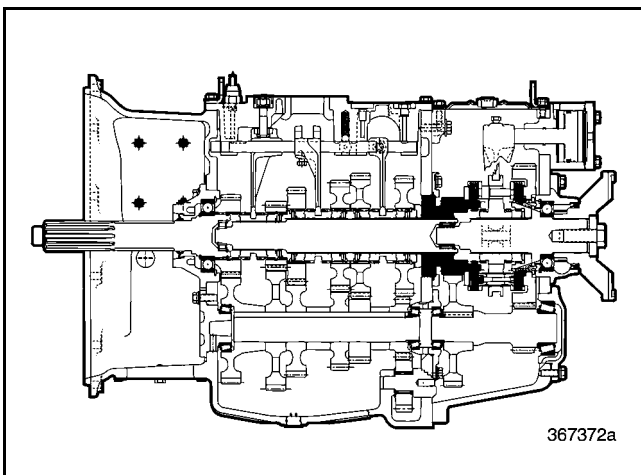

Figure 192 — Compound Main Drive Gear Component Locator

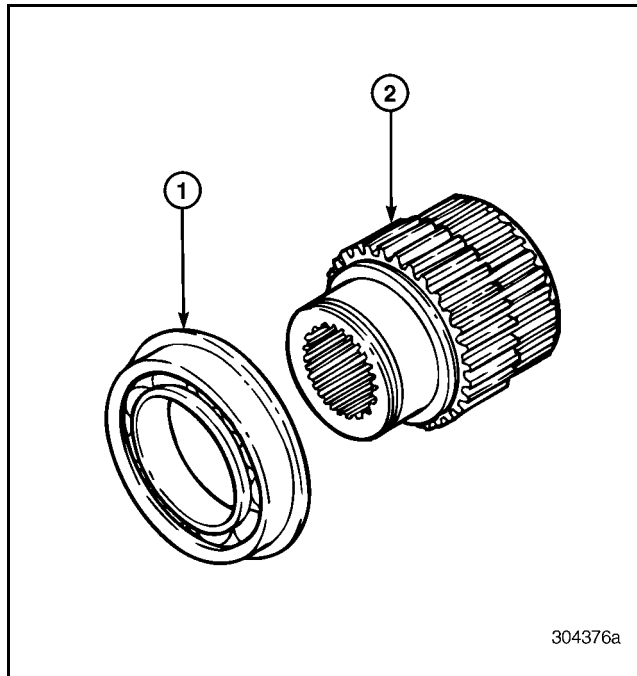

Figure 193 — Exploded View of Compound Main Drive Gear

- | | |
|--------------------------|--------------------|
| 1. Bearing and Snap Ring | 2. Main Drive Gear |
|--------------------------|--------------------|

- Press the bearing off the main drive gear, using a suitable press tool.

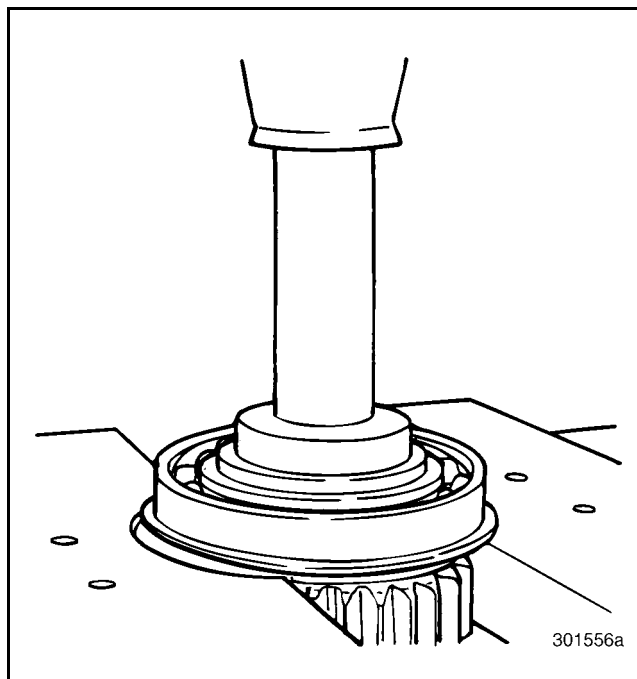

Figure 194 — Pressing off Bearing

- Thoroughly clean the main drive gear and bearing and inspect for damage.



REPAIR INSTRUCTIONS

Front Countershaft Front Bearing Cover Disassembly [321]

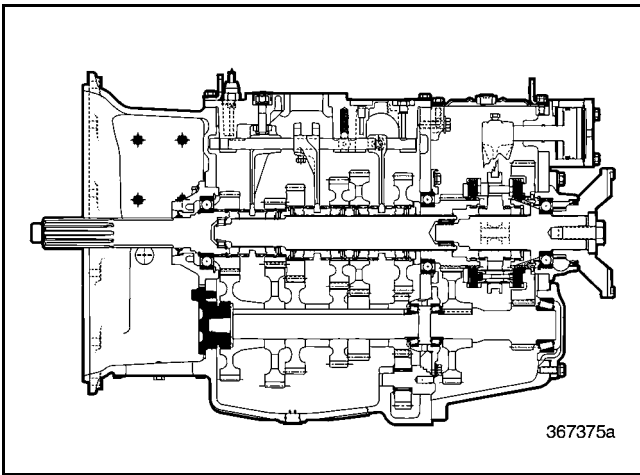

Figure 195 — Front Countershaft Front Bearing Cover Component Locator

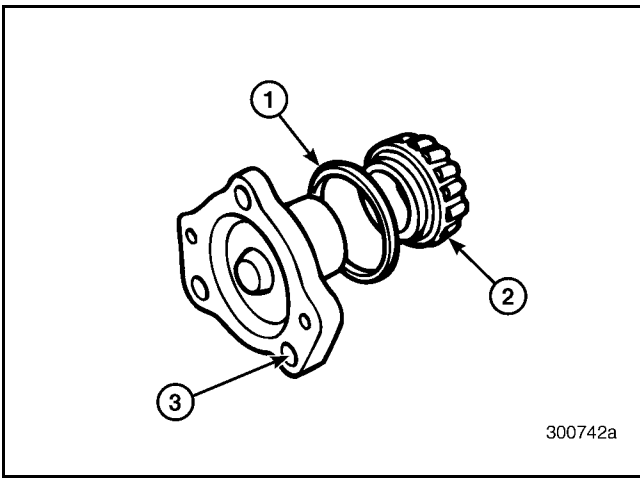

Figure 196 — Exploded View of Front Countershaft Front Bearing Cover

1. O-Ring	3. Front Bearing Cover
2. Bearing Cone	

The following disassembly procedure applies to all front countershaft front bearing covers.

1. Remove the O-ring from the shoulder of the front countershaft front bearing cover.

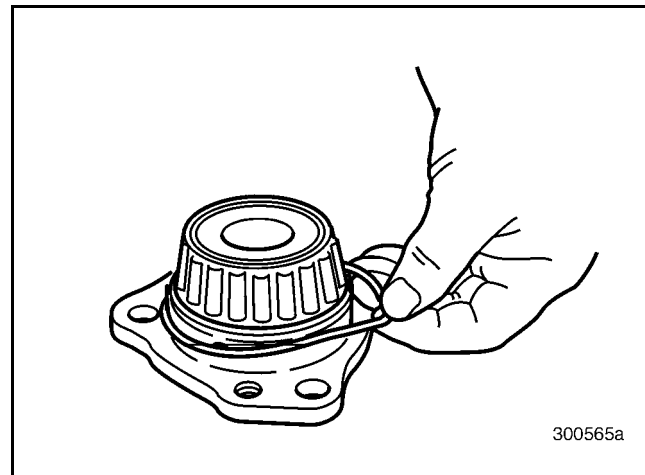

Figure 197 — Removing O-Ring from Shoulder of Front Countershaft Front Bearing Cover

2. Remove the bearing cone from the front countershaft front bearing cover, using a suitable puller.

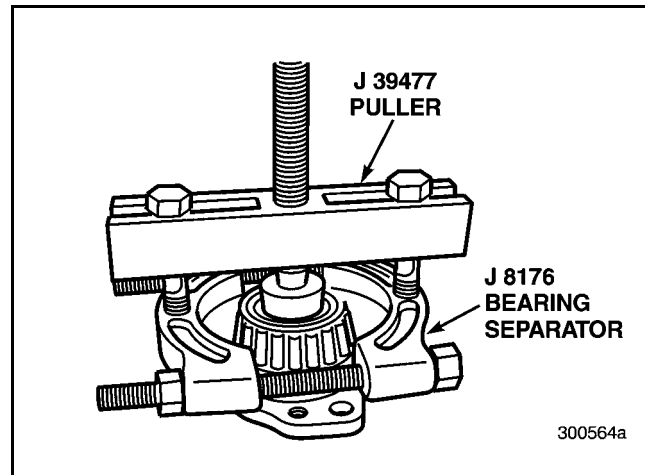

Figure 198 — Removing Bearing Cone from Front Countershaft Front Bearing Cover

3. Thoroughly clean the bearing cover and inspect for damage.



REPAIR INSTRUCTIONS

Front Countershaft Disassembly [322]

The following disassembly procedure applies to all three front countershafts.

! DANGER

The reverse, first and second speed gears on the countershaft must be pressed off the rear end of the shaft. The forward end of the shaft is slightly larger in diameter than the rear. If you try to press any of these gears on or off the forward end of the shaft, the gears can crack, and may fragment explosively, spraying metal pieces outward. This can cause severe injury or death.

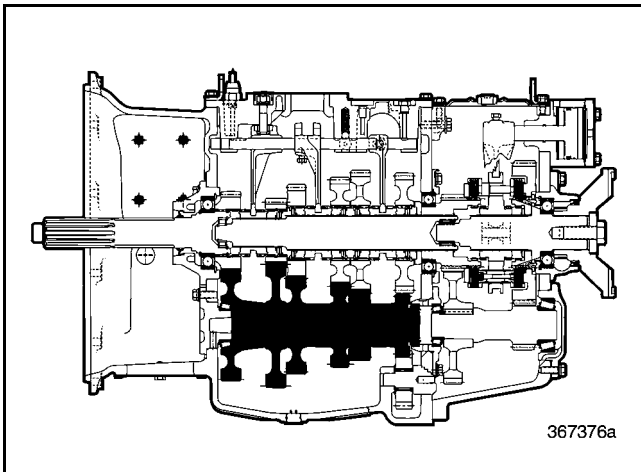

Figure 199 — Front Countershaft Component Locator

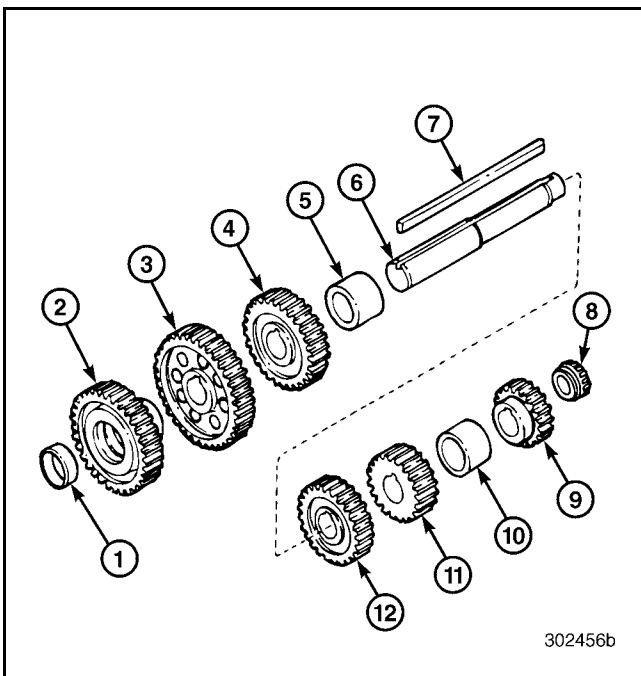

Figure 200 — Exploded View of Front Countershaft

1. Bearing Cup	8. Bearing Cone
2. Main Drive Gear	9. Reverse Speed Gear
3. Fifth (10th) Speed Gear	10. Spacer — Rear
4. Third (8th) Speed Gear	11. First (6th) Speed Gear
5. Spacer — Front	12. Second (7th) Speed Gear
6. Front Countershaft	
7. Key	

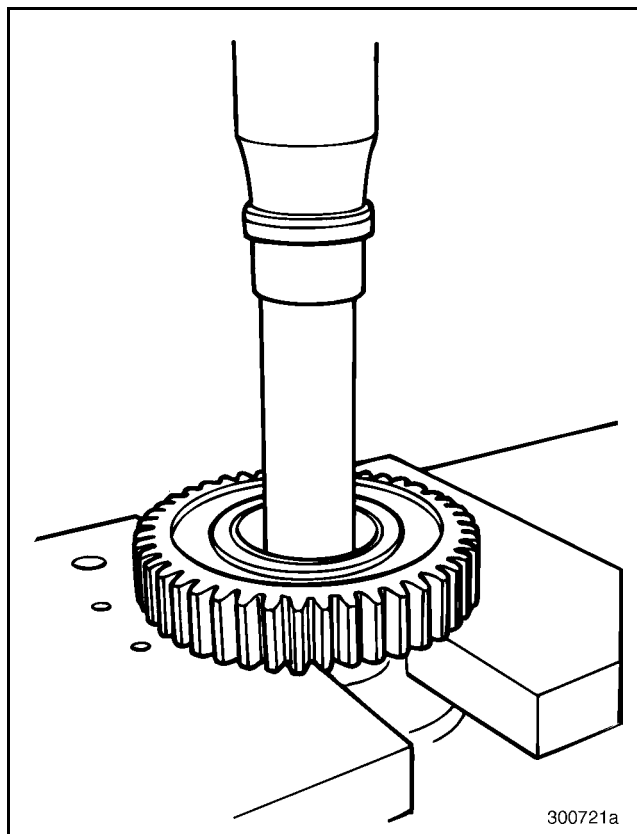

Figure 201 — Pressing Main Drive Gear off Shaft



REPAIR INSTRUCTIONS

2. Press the fifth (10th) speed gear off the front of the countershaft.
3. Press the front countershaft third (8th) speed gear off the front of the countershaft.

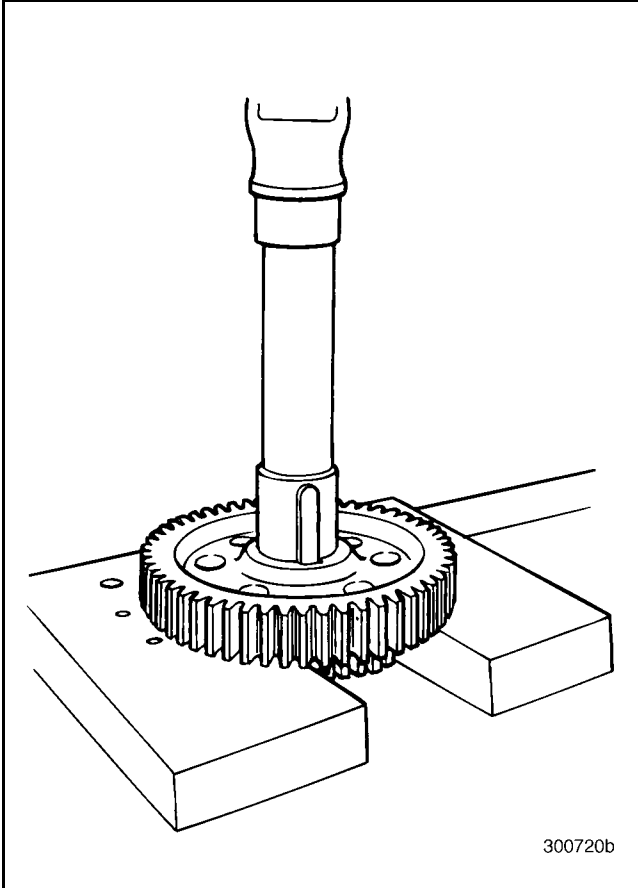

Figure 202 — Pressing Fifth Speed Gear off Shaft

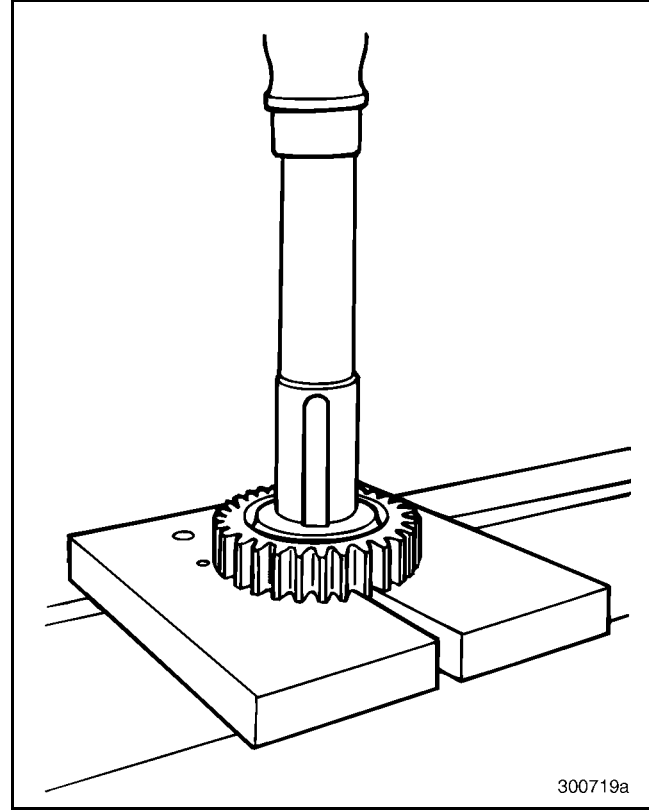

Figure 203 — Pressing Third Speed Gear off Shaft



REPAIR INSTRUCTIONS

4. Remove the front spacer located between the third and second speed gears from the shaft.

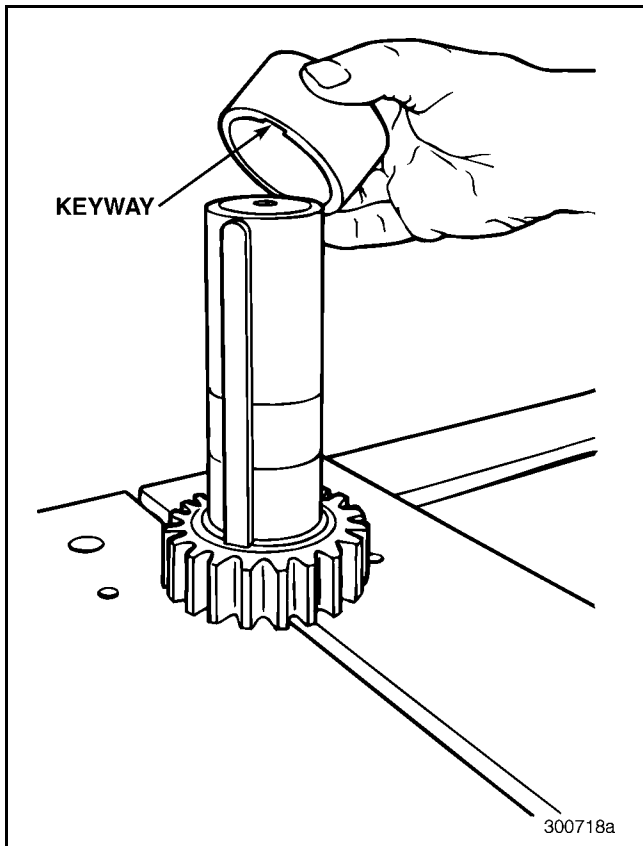

Figure 204 — Removing Spacer

⚠ DANGER

The reverse, first and second speed gears on the countershaft must be pressed off the rear end of the shaft. The forward end of the shaft is slightly larger in diameter than the rear. If you try to press any of these gears on or off the forward end of the shaft, the gears can crack, and may fragment explosively, spraying metal pieces outward. This can cause severe injury or death.

5. Press the reverse gear and rear bearing cone off the rear end of the countershaft.

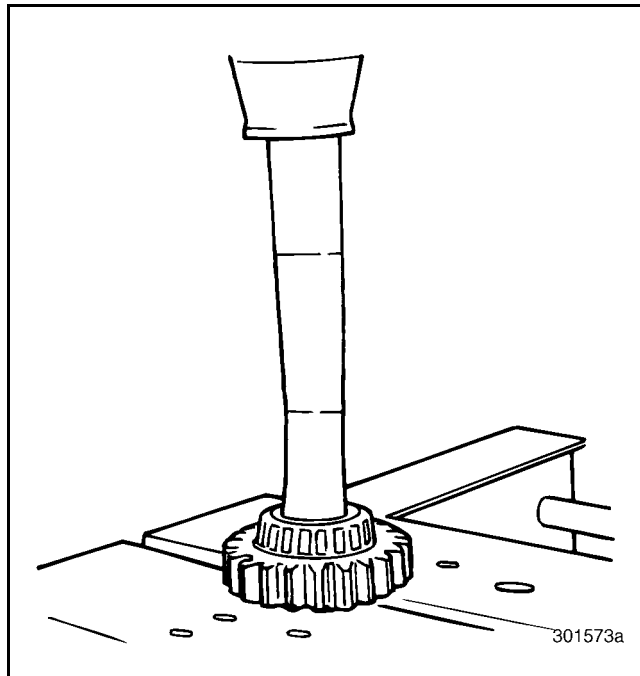

Figure 205 — Pressing off Reverse Gear and Rear Bearing Cone

6. In a similar manner, press off the first (6th) and second (7th) speed gears from the rear of the countershaft. The previous warning also applies when pressing these gears off the countershaft.
7. Remove the key from the keyway of the front countershaft.

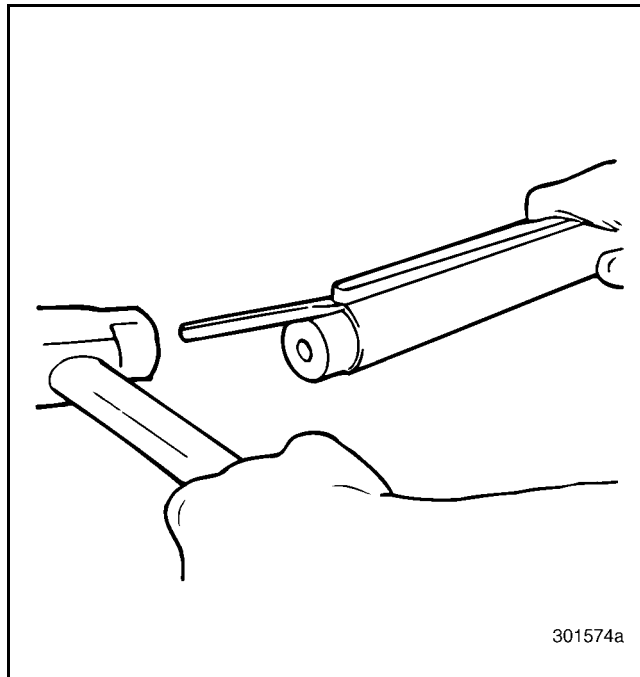

Figure 206 — Removing Key



REPAIR INSTRUCTIONS

- Remove the bearing cup from the front countershaft main drive gear, using a suitable puller.

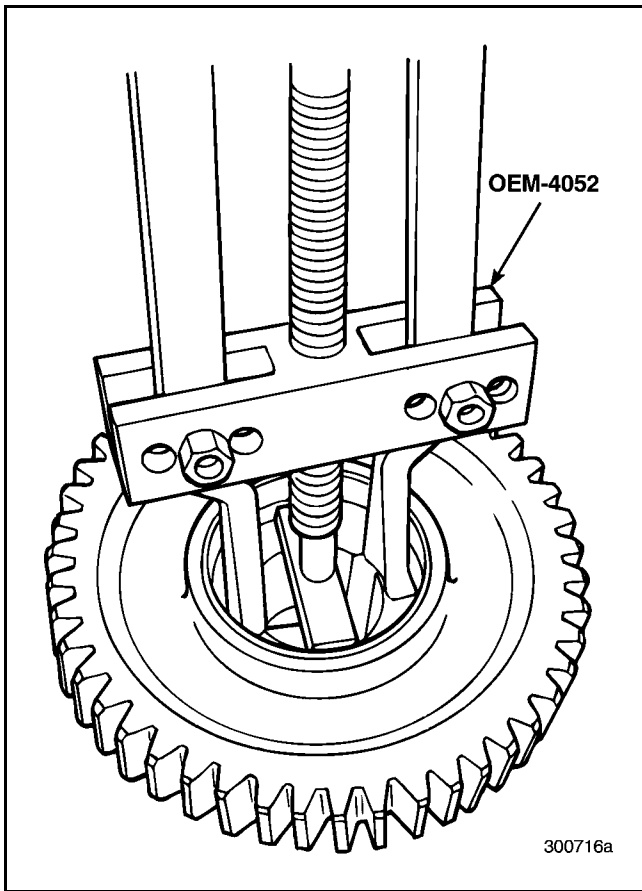

Figure 207 — Removing Bearing Cup from Main Drive Gear

Front Countershaft Rear Bearing Cover Disassembly [321]

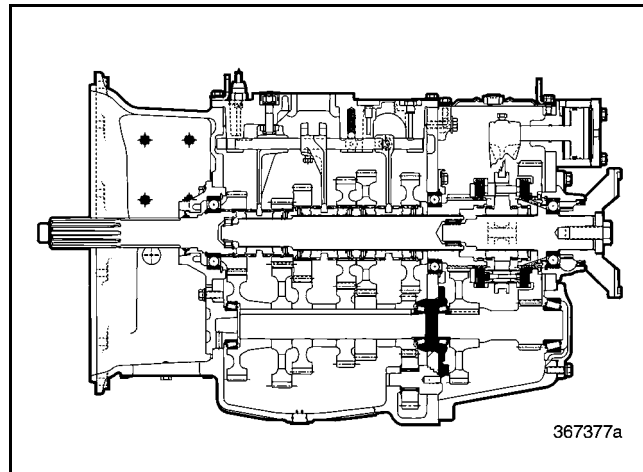

Figure 208 — Front Countershaft Rear Bearing Cover Component Locator

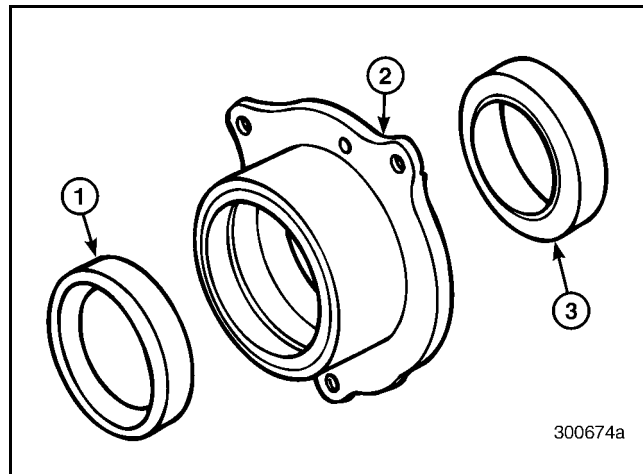

Figure 209 — Exploded View of Front Countershaft Rear Bearing Cover

1. Front Bearing Cup
2. Bearing Cover

3. Rear Bearing Cup



REPAIR INSTRUCTIONS

1. Remove the front and rear bearing cups from the front countershaft rear bearing cover.

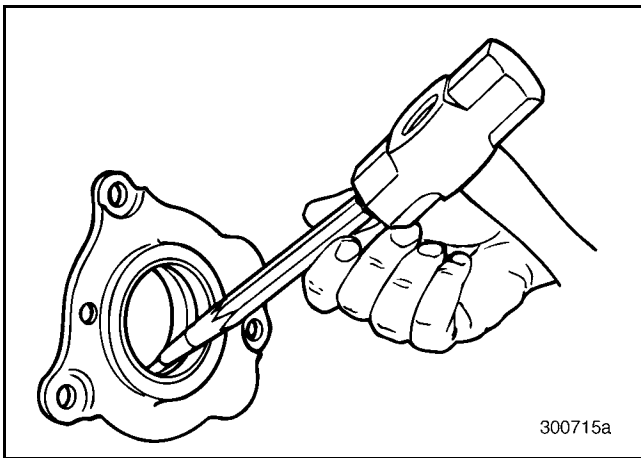

Figure 210 — Removing Front Bearing Cup

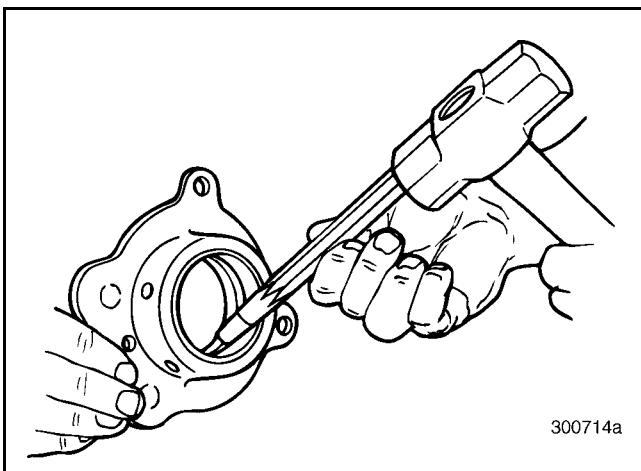

Figure 211 — Removing Rear Bearing Cup

2. Thoroughly clean the bearing cover and inspect for damage.

Rear Countershaft Disassembly [322]

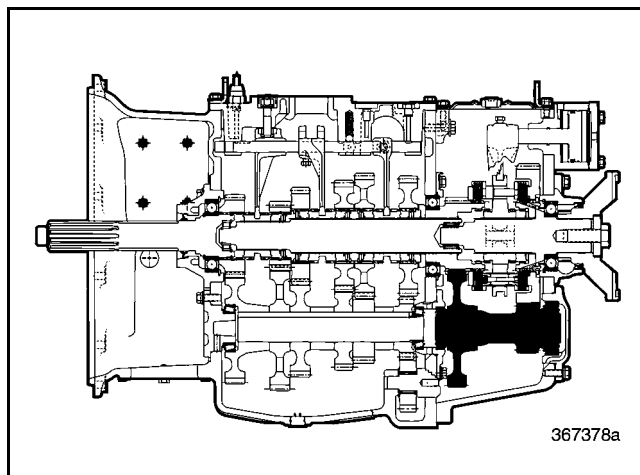

Figure 212 — Rear Countershaft Component Locator

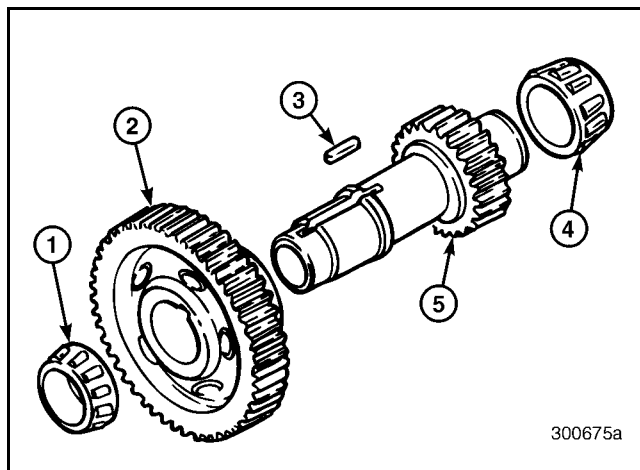

Figure 213 — Exploded View of Rear Countershaft

1. Front Bearing Cone	5. Rear Countershaft (Lo-Range Gear Integral with Shaft)
2. Main Drive Gear	
3. Key	
4. Rear Bearing Cone	

⚠ DANGER

Do not attempt to press-remove the Lo-range gears off these rear countershafts. This gear is integral with the shaft and could fragment explosively when pressing action is attempted.



REPAIR INSTRUCTIONS

1. If not previously done at disassembly, press the rear bearing cone off the rear countershaft.

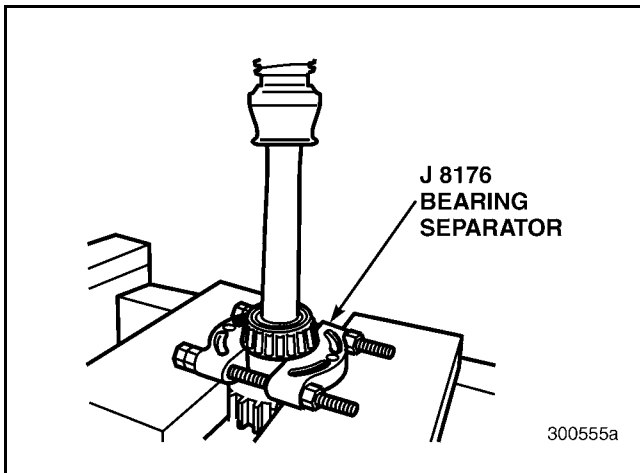

Figure 214 — Pressing off Rear Bearing Cone

2. Press the rear countershaft main drive gear and the front bearing cone off the countershaft.

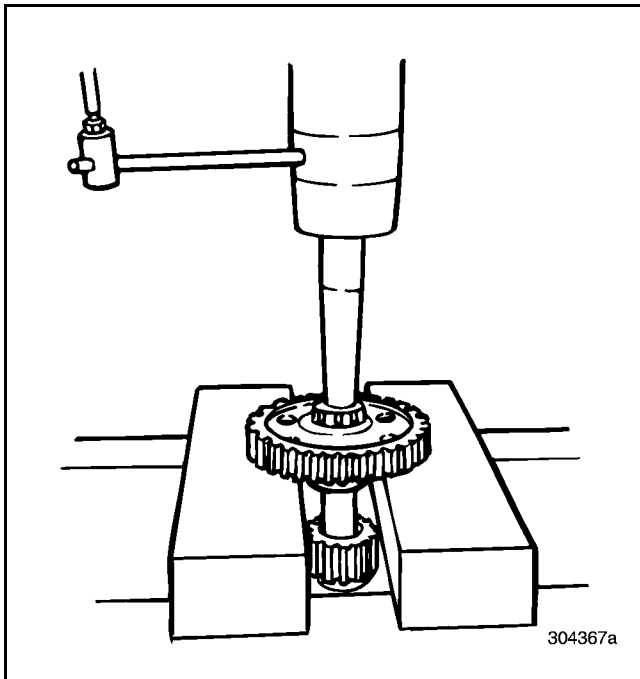

Figure 215 — Pressing off Gear and Bearing

3. Remove the key from the keyway of the rear countershaft.

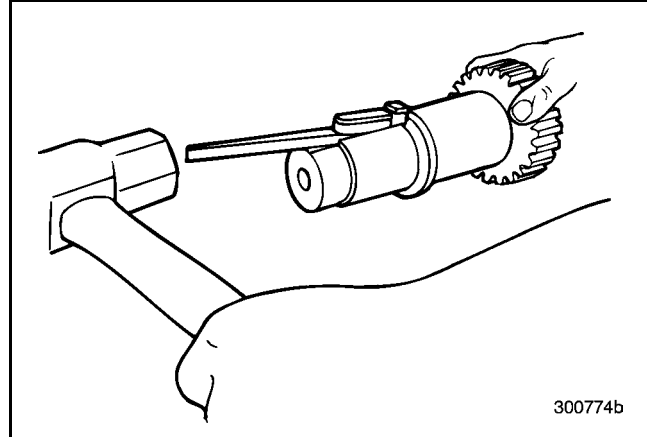

Figure 216 — Removing Key



REPAIR INSTRUCTIONS

Rear Countershaft Bearing Cover Disassembly [321]

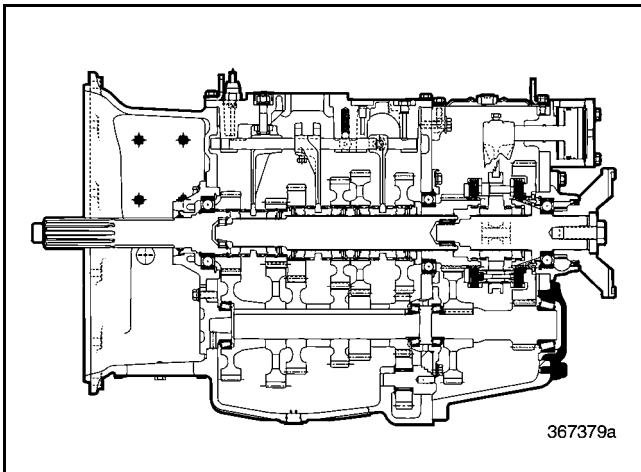

Figure 217 — Rear Countershaft Bearing Cover Component Locator

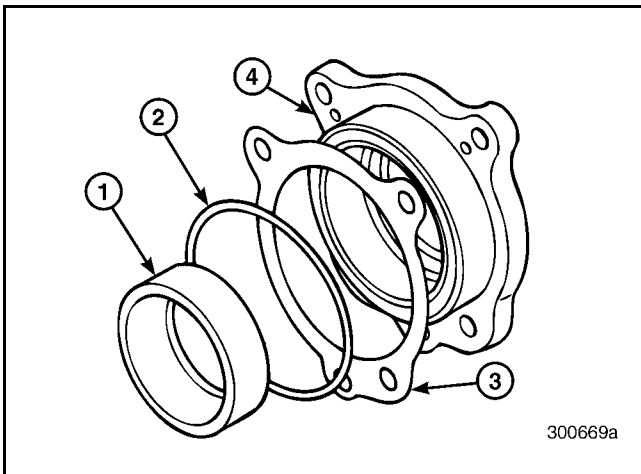

Figure 218 — Exploded View of Rear Countershaft Bearing Cover

- | | |
|----------------|------------------|
| 1. Bearing Cup | 3. Shim(s) |
| 2. O-Ring | 4. Bearing Cover |

The following disassembly procedure applies to all three rear countershaft bearing covers.

1. Remove the shim(s) and O-ring from the shoulder of the countershaft rear bearing cover. Tag the shim(s) and record the markings for use during assembly.

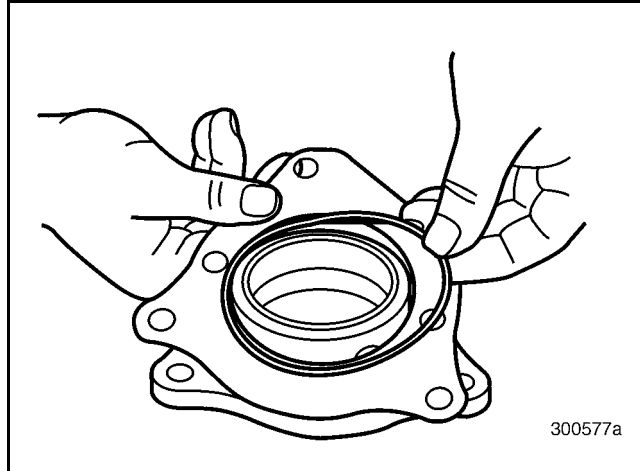

Figure 219 — Removing Cover Shims and O-Ring

2. Remove the bearing cup from the bearing cover, using a suitable puller.

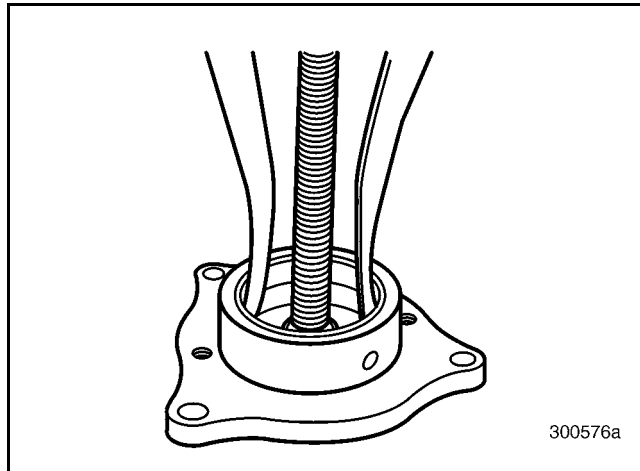

Figure 220 — Removing Bearing Cup from Cover

3. Thoroughly clean the bearing cover and inspect for damage.



REPAIR INSTRUCTIONS

Reverse Idler Gear Disassembly [322]

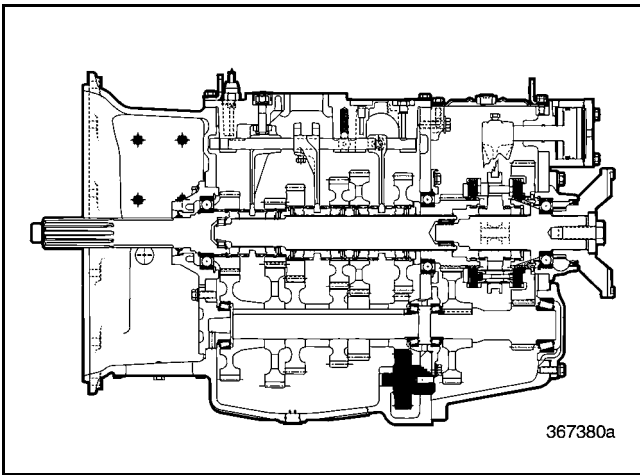

Figure 221 — Reverse Idler Gear Component Locator

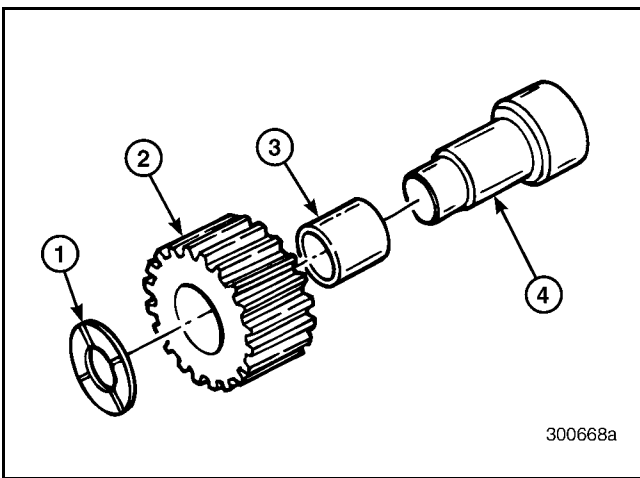

Figure 222 — Exploded View of Reverse Idler Gear Assembly

1. Thrust Washer	3. Bearing
2. Reverse Idler Gear	4. Reverse Idler Shaft

Reverse idler gear disassembly applies to all reverse idler gears.

1. Press the bearing out of the reverse idler gear, using a suitable driver.

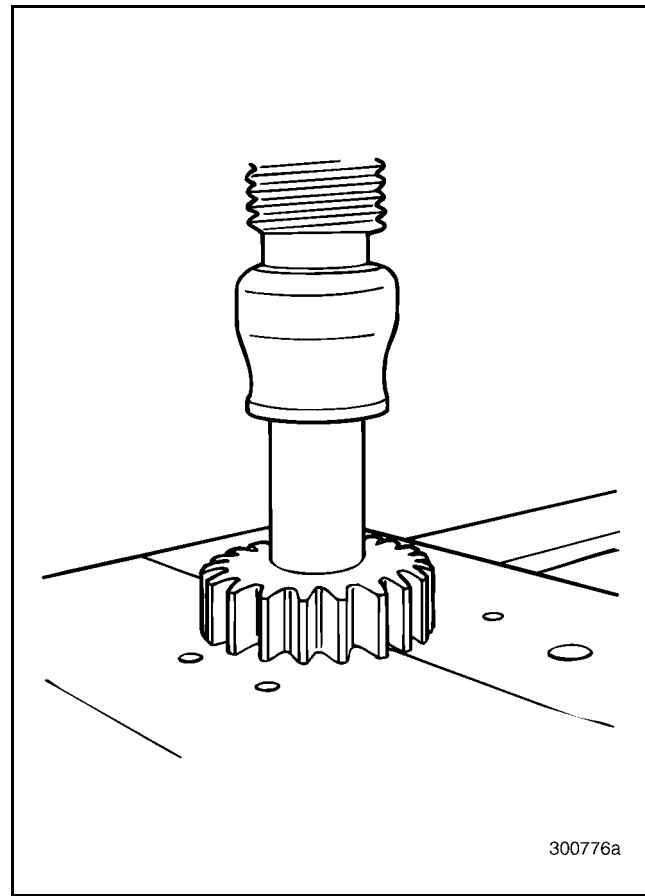

Figure 223 — Pressing out Reverse Idler Gear Bearing

2. Thoroughly clean the reverse idler gear and inspect for damage.



REPAIR INSTRUCTIONS

INSPECTION OF PARTS

Inspection and Cleaning

Thoroughly clean the cases, covers and all other parts of the transmission. Remove all grease, oil and foreign matter, using a suitable safety solvent. Dry the parts with moisture-free compressed air.

Bearings [322]

Soak bearings in fresh clean solvent to loosen all hardened grease and foreign matter, until the bearings are clean. Blow them dry with filtered, moisture-free compressed air.

CAUTION

Do not spin the bearings with compressed air. Doing so can damage the bearings.

Inspect each bearing for flaking, cracks, fractures, cavities, indentations, measurable wear, brinelling, fretting, corrosion, nicking, cage wear or deformation and other damage. If any of these conditions are present, the bearing should be replaced.

Apply a light coat of fresh, clean, specified gear oil to the bearings. (Refer to Recommended SAE Grade Gear Oil in "Transmission Specifications and Capacities" on page 176.) Turn the races and bearings slowly by hand to be sure they move freely and are smooth. If there is resistance to movement, or if the bearing cones or cups feel rough, replace the bearings.

CAUTION

If a bearing cone or cup needs replacement, a complete new assembly, including cup and mating cone, is required.

*Do not remove a **new** bearing from its packing before time of installation. Never clean protective grease from new bearings.*

Do not handle bearings with dirty hands. Rags must be clean and lint free.

Clean the bearings that are satisfactory for installation. Wrap the bearings in clean, lint-free cloth and store for assembly.

Gears [322]

Replace all gears having teeth that show signs of abrasive wear, scratching (except normal manufacturing tool marks), ridging, scoring, surface fatigue, pitting, spalling, corrosive wear, digging in or cracking. Gears should always be inspected using magnaflux (or similar method) for cracks that would not otherwise be detected.

Shifter Forks, Sliding Clutches and Shift Rails [323]

Replace forks and/or sliding clutches when the side clearance (A) between the fork (2) and sliding clutch (1) groove exceeds the specified limit (refer to "Fits and Limits" on page 174).

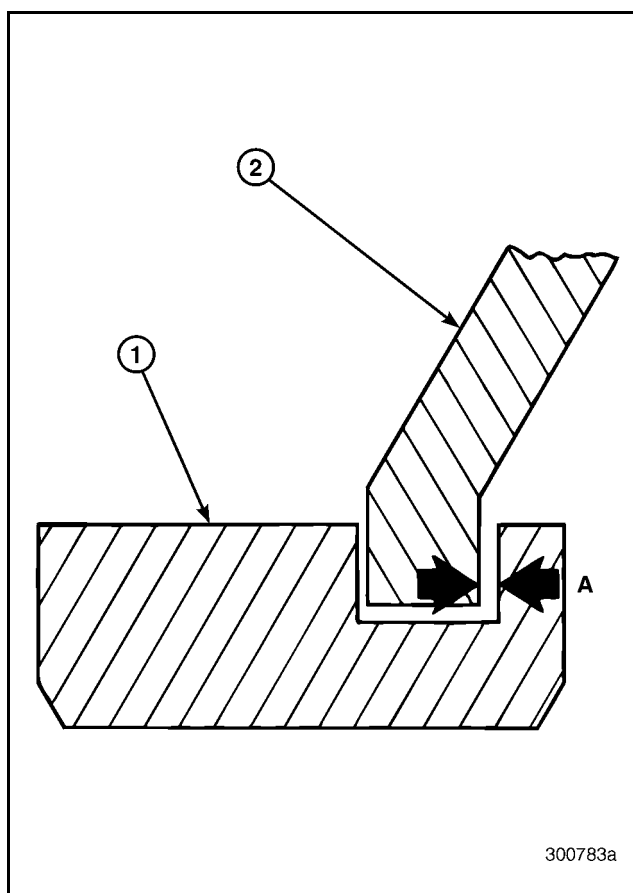

Figure 224 — Fork and Clutch Detail



REPAIR INSTRUCTIONS

Replace shift rails if they are cracked in either the poppet or setscrew holes. If the clearance between the shift rail and housing (cover) bore exceeds 0.010 inch (0.254 mm) maximum, determine which part is worn before replacing. Shaft wear can be checked by measuring the shaft at an unworn location. Then measure the shaft at the worn area and compare measurements. When measuring a shift rail, the reading should be an average of diameter measurements taken at four locations. Compare one side of the shaft to the other, AB-CD as shown in Figure 225.

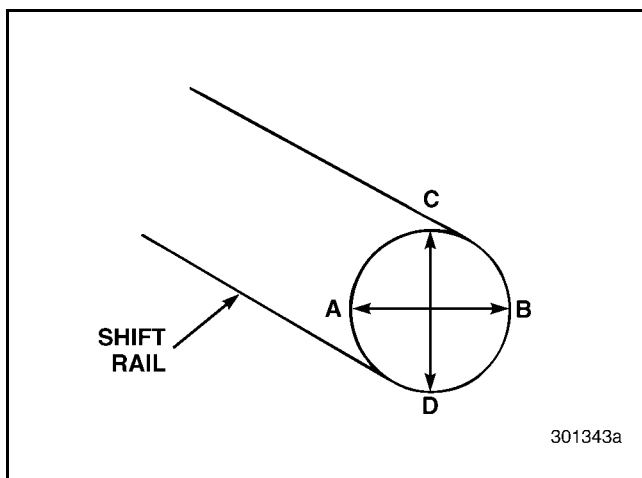

Figure 225 — Measuring Shift Rail

Oil Seals [321]

When an overhaul is required, replace all oil seals. Be careful to ensure that the sealing surface of any seal is not damaged, turned back or cut. A nick on a shaft sealing surface can cut the seal. Remove sharp edges that can damage the seal (chamfer edges if possible). Press seals into housings, using smooth, even pressure to prevent cocking the seal.

CAUTION

Be careful when using any abrasive polishing methods, such as emery or crocus cloth, on a sealing surface. It is possible to leave microgrooves on the sealing surface. This can cause oil to leak past the sealing lip(s) of the oil seal. With this condition, a new seal will not stop the oil leak.

Be careful when installing a shaft through a **new** seal (or seal over shaft). Lubricate the shaft before inserting it through the seal. Splines, keyways and holes in a shaft can damage seals unless care is taken. Lubricate the seal to prevent damage during the initial start-up period, before normal lubrication begins. Keep anti-seize and sealing compounds away from oil seals.

If an oil seal does not have a preapplied sealant on its outer diameter, apply an appropriate sealer around the outside diameter to prevent leaks.

Lip-type oil seals are precision elements that require close attention and care during installation.

NOTE

The quality of the installation method and tools used has a direct influence on the life of the seal. Do not use a block of wood or discarded bearing as a substitute for the proper seal driver.

However, with some seal applications, a seal driver may not be available. In these situations, light tapping in a circular motion using a light, broad-faced hammer is acceptable.

For the seal to function properly, install it squarely with respect to the shaft center line. The seal should be kept square within 0.010 inch (0.254 mm) Total Indicated Runout (TIR). Squareness of the seal to the shaft is controlled by using the proper seal installation tools, as shown in Figure 226 and Figure 227.

Press seals into housings using smooth, even pressure to prevent cocking or distorting the seal. Gently press the seal into place. Correct installation depth is achieved as the driver tool bottoms against the positioning tool, as shown.



REPAIR INSTRUCTIONS

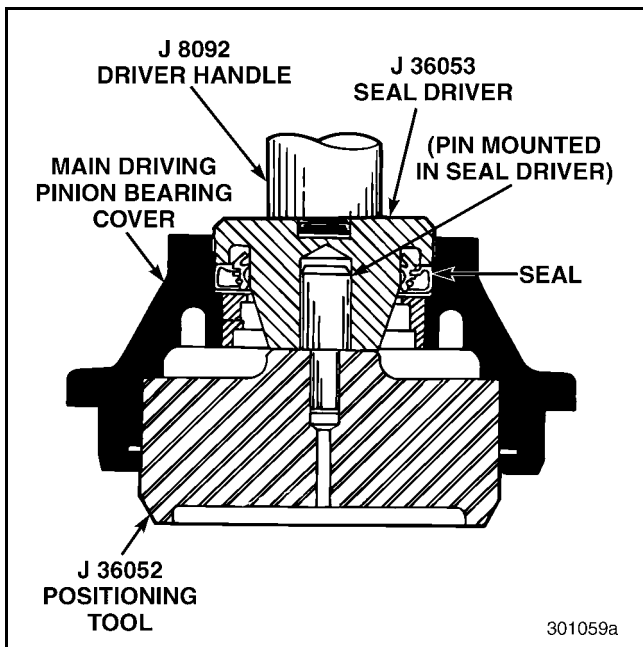

Figure 226 — Main Drive Pinion Oil Seal Tools

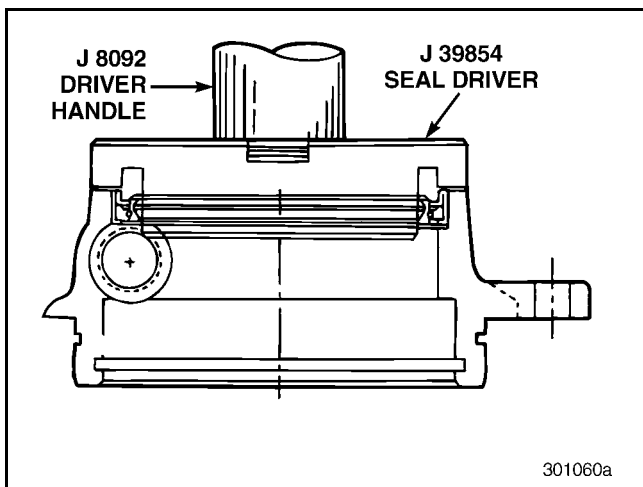

Figure 227 — Rear Mainshaft Bearing Cover Oil Seal Tools

General Inspection

Any cracked transmission case should be replaced. Check all components for wear or damage. Replace all parts as required. Replace all gaskets, O-rings, and any part that shows mutilation or damage. Repair all stripped threads, using a thread repair insert that is compatible with patch-lock type capscrews.

General Reassembly Instructions

Refer to "Fits and Limits" on page 174 for fits and limits and "Torque Specifications" on page 170 for torque specifications.

All working metal parts, especially the bearings, should be coated with fresh, clean, specified gear oil while the transmission is being reassembled. This ensures immediate lubrication and helps prevent parts seizure during start-up. (Refer to Recommended SAE Grade Gear Oil in "Transmission Specifications and Capacities" on page 176.)

When installing bearings, use proper bearing drivers. When pressing a bearing onto a shaft, apply force to the inner race of the bearing. When pressing a bearing into a housing (bearing cover), apply force only to the outer race. Do not apply force that is transmitted through the bearing rollers, balls or cage. Damage and premature bearing failure can result. Always apply even pressure to the bearing to prevent it from cocking or distorting during installation.

As moving parts are installed, check the parts frequently to see that they are moving freely.



REPAIR INSTRUCTIONS

TRANSMISSION COMPONENT REASSEMBLY [320]

Reverse Idler Gear Reassembly [322]

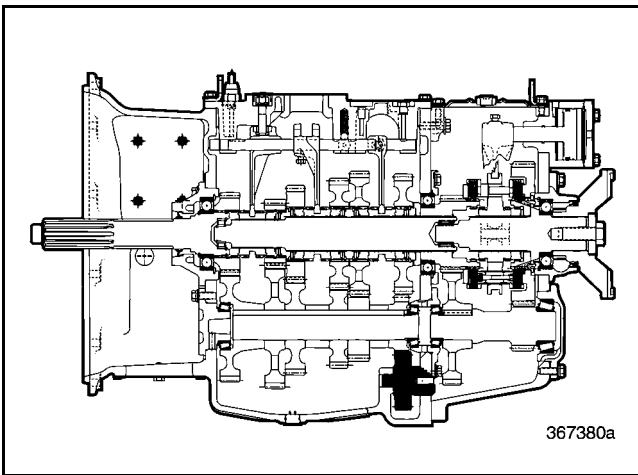

Figure 228 — Reverse Idler Gear Component Locator

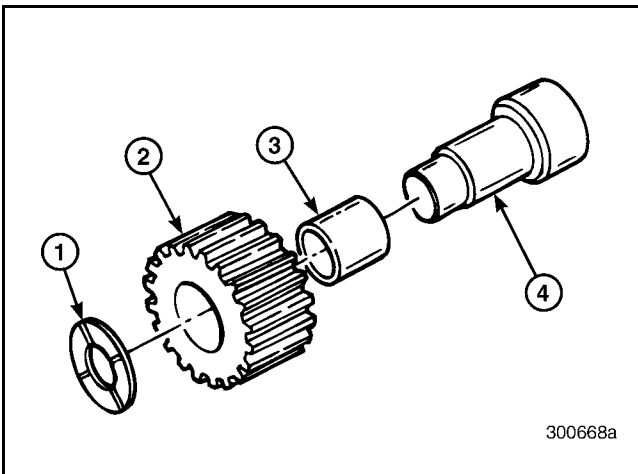

Figure 229 — Exploded View of Reverse Idler Gear Assembly

1. Thrust Washer	3. Bearing
2. Reverse Idler Gear	4. Reverse Idler Shaft

1. Install a **new** caged needle bearing into the reverse idler gear. Press the bearing until flush with gear surface. The bearing must not protrude on either side of the gear surface.

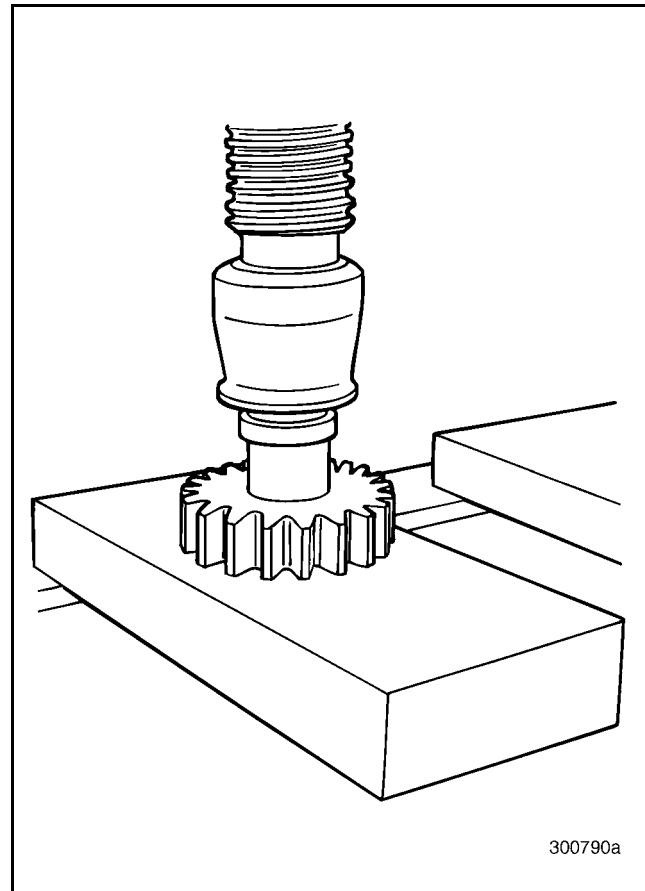

Figure 230 — Pressing Bearing into Gear

NOTE

Drawn cup needle bearings (reverse idler gear bearings) have a specific direction that they must be installed. The radius end of the bearing is to be installed first. The flat end (the end with identification markings) faces against the angled shoulder of the pressing tool.



REPAIR INSTRUCTIONS

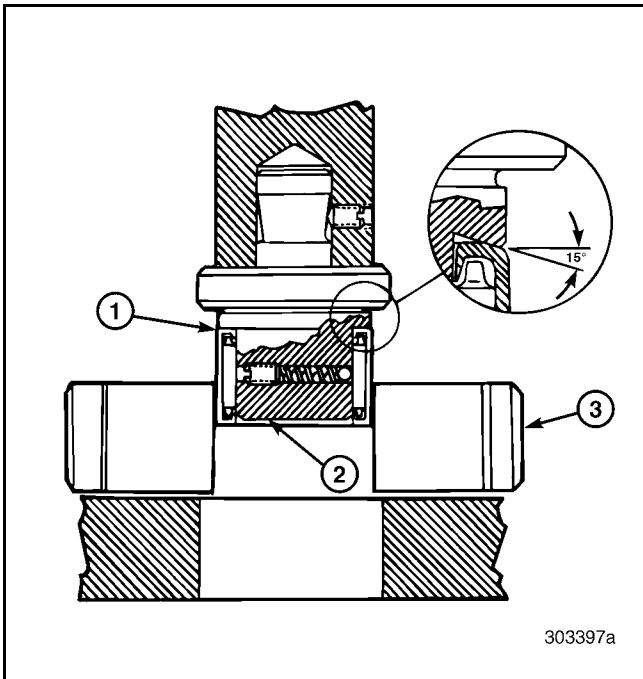

Figure 231 — Installation of Drawn Cup Bearings

1. Stamped End of Bearing	3. Reverse Idler Gear
2. Press Tool Leader or Pilot	

Rear Countershaft Bearing Cover Reassembly [321]

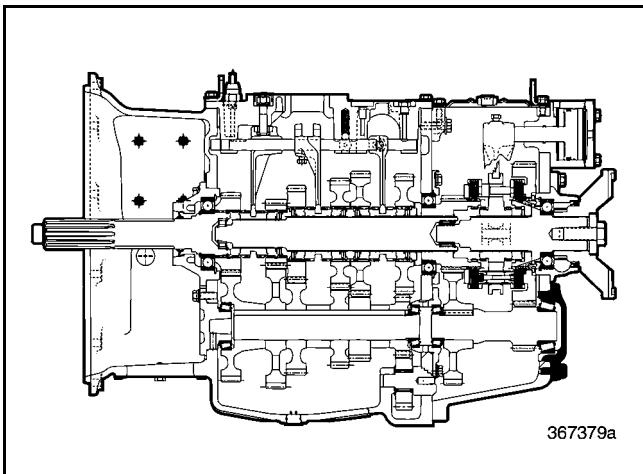

Figure 232 — Rear Countershaft Bearing Cover Component Locator

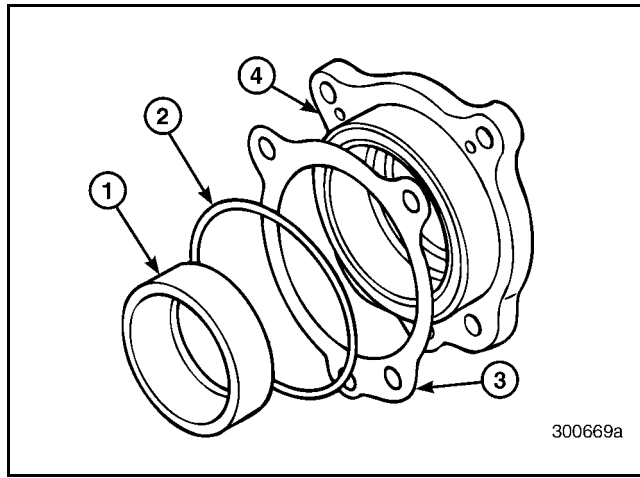

Figure 233 — Exploded View of Rear Countershaft Bearing Cover

1. Bearing Cup	3. Shim(s)
2. O-Ring	4. Bearing Cover

The following reassembly procedure applies to all three rear countershaft bearing covers.

1. Press the bearing cup into the cover, using a suitable driver.

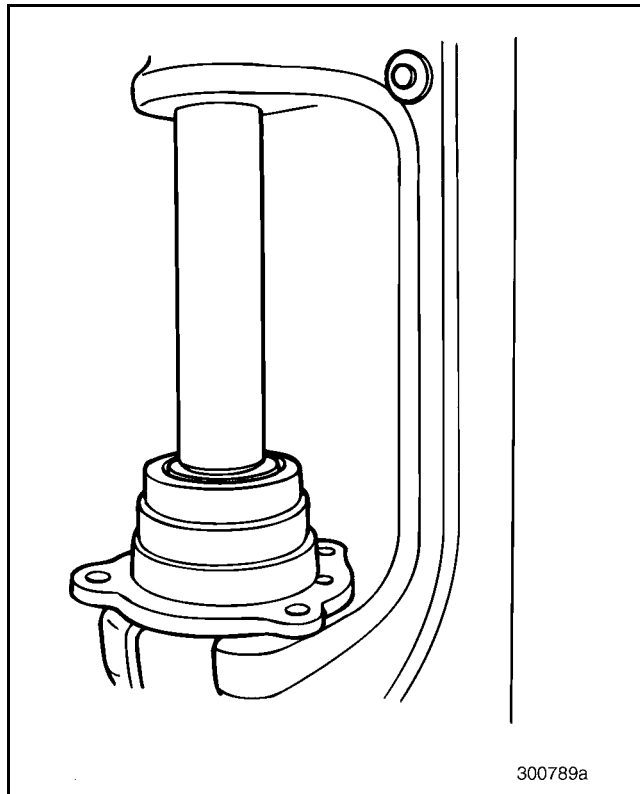

Figure 234 — Pressing Bearing Cup into Cover



REPAIR INSTRUCTIONS

- Keep the original shims and a **new** O-ring with each cover for reassembly. Bearing preload adjustments must be made before installing shim pack and O-ring.

Rear Countershaft Reassembly [322]

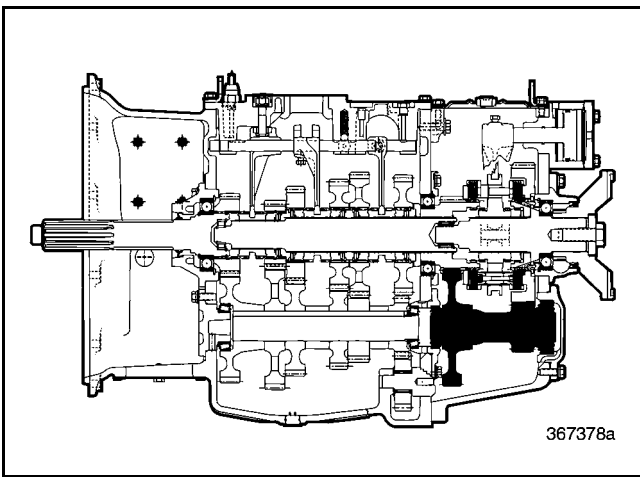

Figure 235 — Rear Countershaft Component Locator

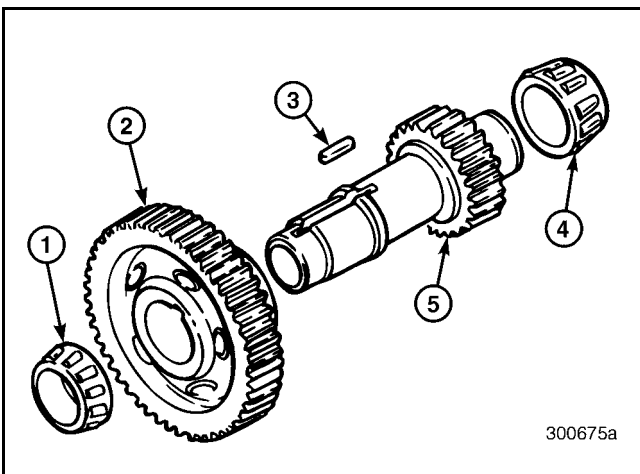

Figure 236 — Exploded View of Rear Countershaft

- | | |
|-----------------------|----------------------|
| 1. Front Bearing Cone | 4. Rear Bearing Cone |
| 2. Main Drive Gear | 5. Rear Countershaft |
| 3. Key | |

⚠ DANGER

Do not attempt to press-remove the Lo-range gear off these rear countershafts. The gear is integral with the shaft and could fragment explosively when pressing action is attempted.

- Install the key into the keyway of the rear countershaft, using a soft-faced mallet.

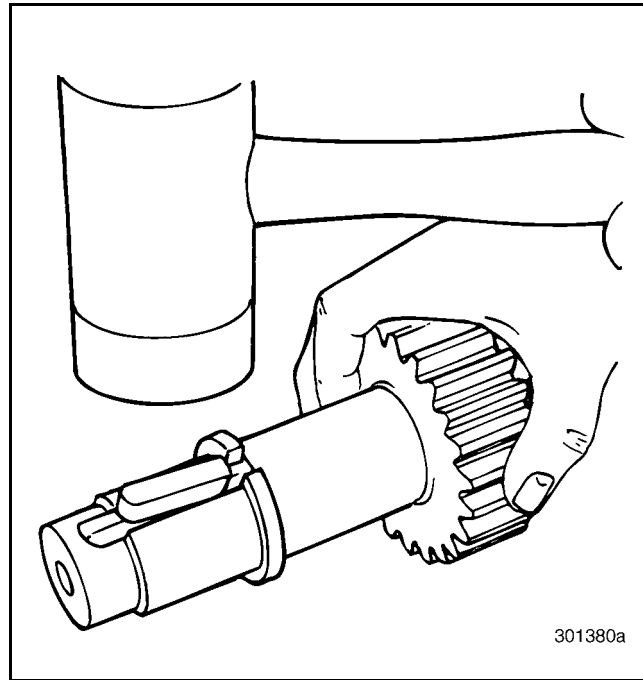

Figure 237 — Installing Key

- Press the rear countershaft main drive gear onto the rear countershaft. Place the gear onto the shaft, with the protruding hub toward the rear of the shaft.

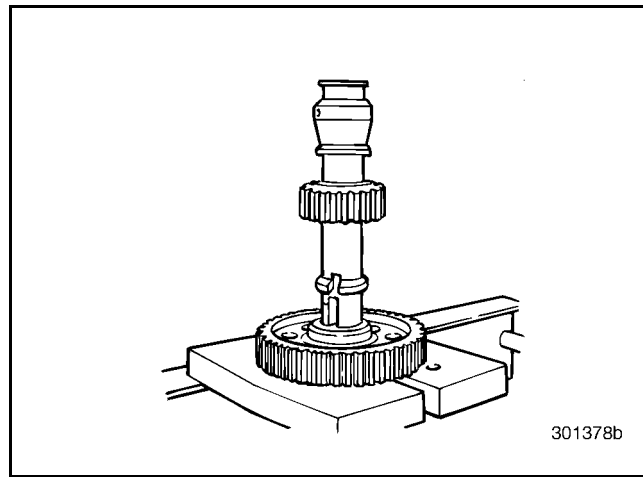

Figure 238 — Pressing on Main Drive Gear



REPAIR INSTRUCTIONS

3. Press the front bearing cone onto the rear countershaft, using a suitable driver. Apply force to the inner race only.

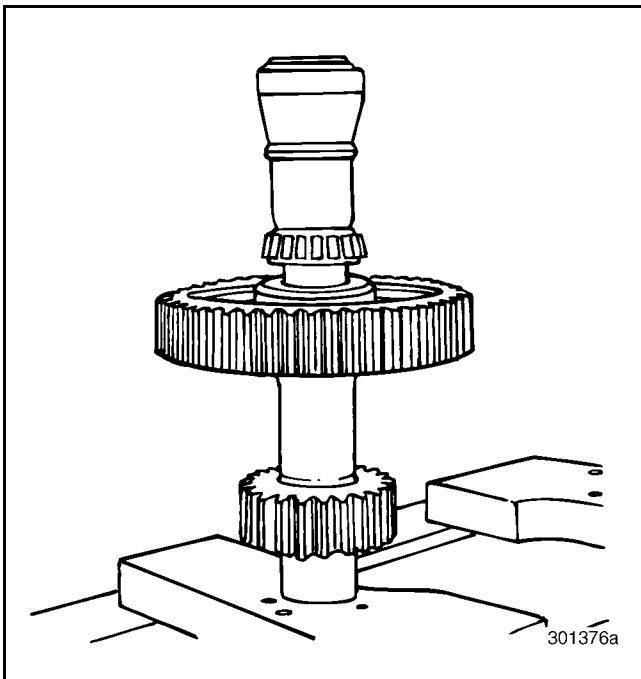

Figure 239 — Pressing on Front Bearing Cone

NOTE

Do not install the countershaft rear bearing cone until transmission reassembly. Bearing installation is delayed as this bearing overhangs the mainshaft Lo-gear and blocks mainshaft installation. Countershaft rear bearing will be installed after mainshaft installation and gear timing check.

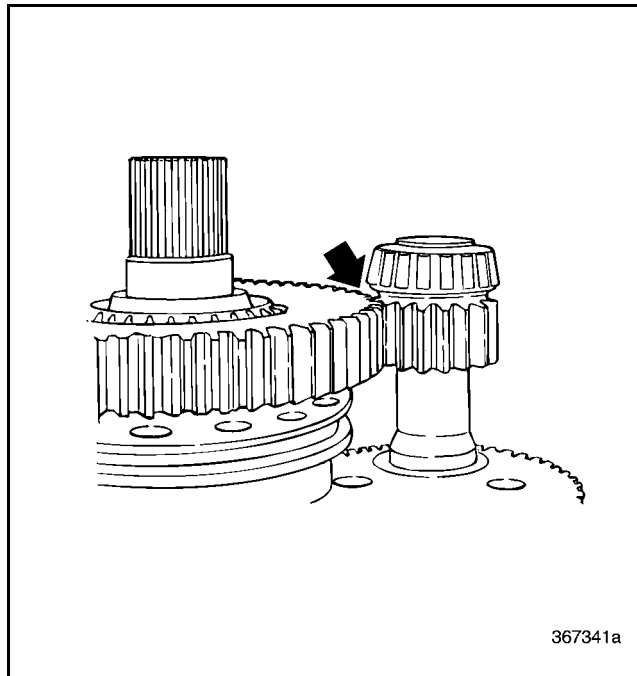

Figure 240 — Rear Countershaft Rear Bearing Overhang

Front Countershaft Rear Bearing Cover Reassembly [321]

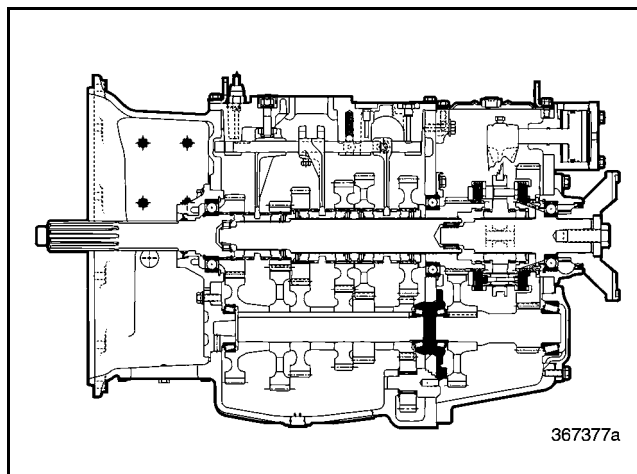

Figure 241 — Front Countershaft Rear Bearing Cover Component Locator



REPAIR INSTRUCTIONS

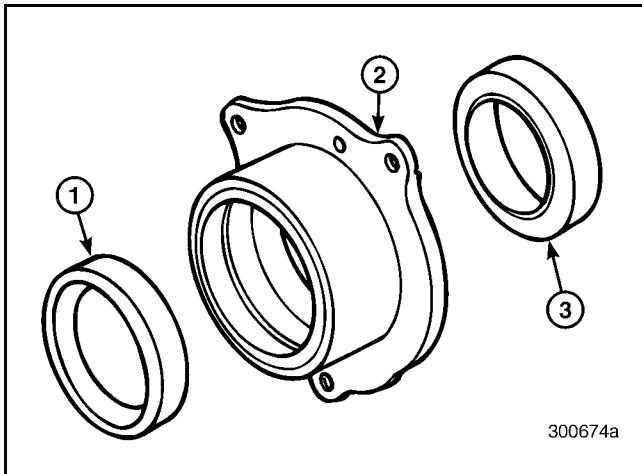

Figure 242 — Exploded View of Front Countershaft Rear Bearing Cover

- | | |
|----------------------|---------------------|
| 1. Front Bearing Cup | 3. Rear Bearing Cup |
| 2. Bearing Cover | |

1. Press the front and rear bearing cups into the front countershaft rear bearing cover, using a suitable driver.
2. Set the front countershaft rear bearing cover aside for later installation.

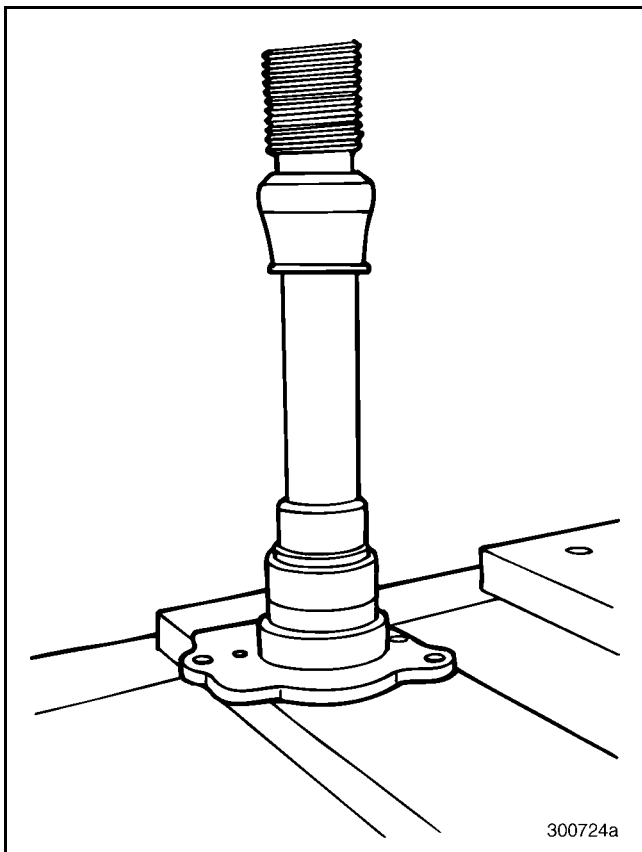

Figure 243 — Pressing Front Bearing Cup into Cover

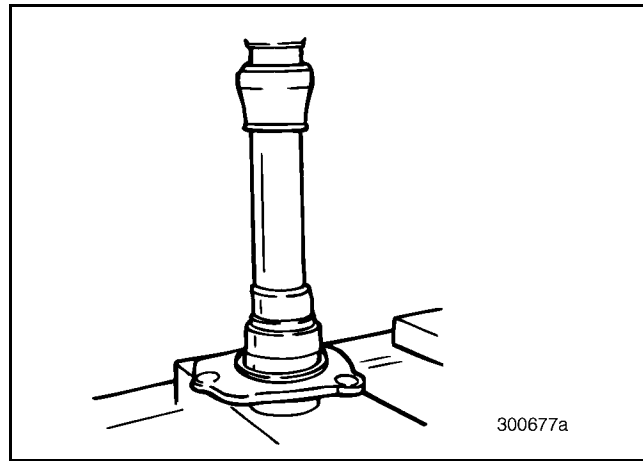

Figure 244 — Pressing Rear Bearing Cup into Cover

Front Countershaft Reassembly [322]

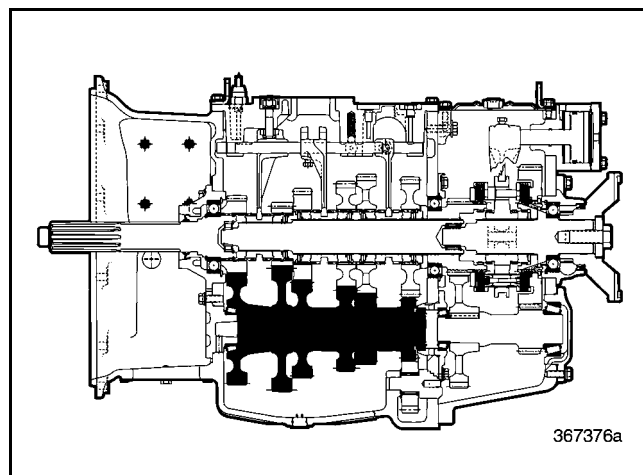

Figure 245 — Front Countershaft Component Locator



REPAIR INSTRUCTIONS

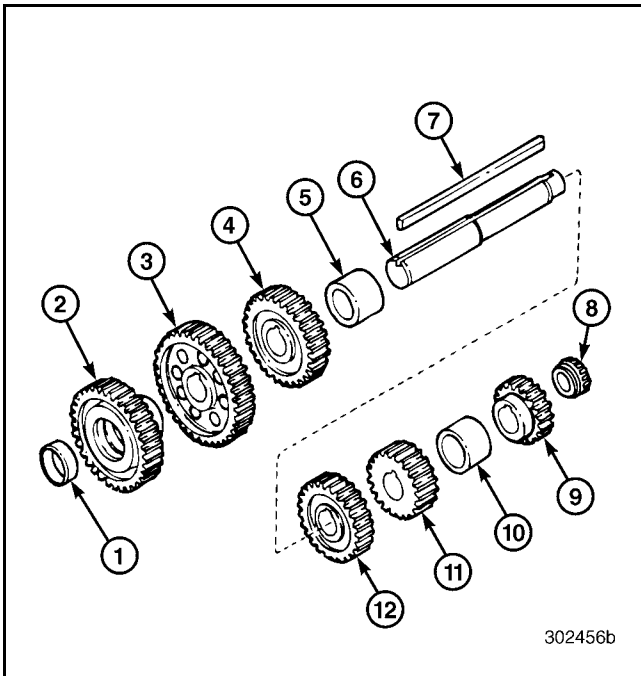

Figure 246 — Exploded View of Front Countershaft

1. Bearing Cup	8. Bearing Cone
2. Main Drive Gear	9. Reverse Speed Gear
3. Fifth (10th) Speed Gear	10. Spacer — Rear
4. Third (8th) Speed Gear	11. First (6th) Speed Gear
5. Spacer — Front	12. Second (7th) Speed Gear
6. Front Countershaft	
7. Key	

The following reassembly procedure applies to all three front countershafts.

NOTE

Remember to apply the recommended oil to all shaft and gear surfaces before pressing parts together.

⚠ DANGER

Do not attempt to press the reverse, first or second speed gears onto the front end of the countershaft. The front end of the shaft is slightly larger in diameter than the rear of the shaft. Attempting to press any of these three gears onto the front end of the shaft can cause the gears to crack and fragment explosively, and cause personal injury or death.

1. Press the bearing cup into the front countershaft main drive gear, using a suitable driver.

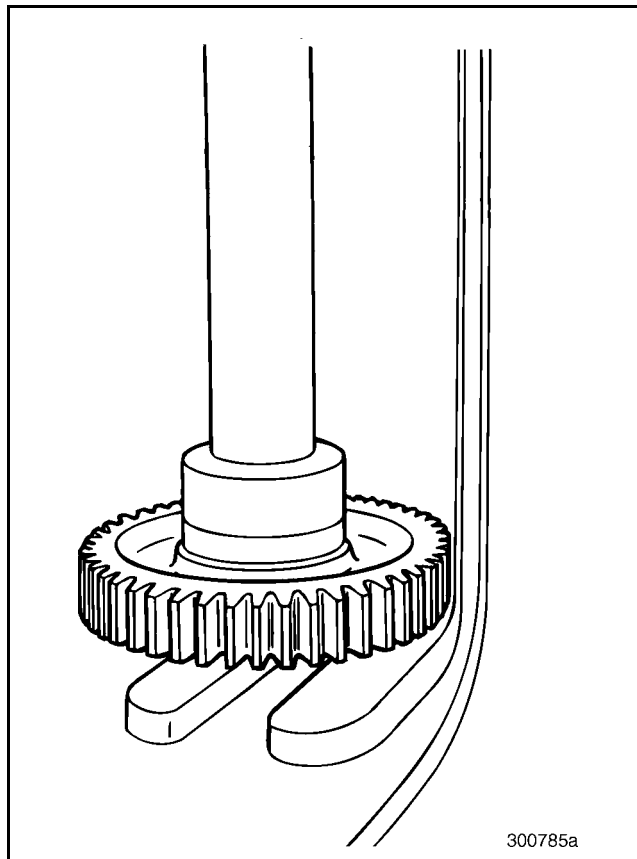

Figure 247 — Pressing Bearing Cup into Main Drive Gear

2. Install the key into the keyway of the front countershaft, using a soft-faced mallet.

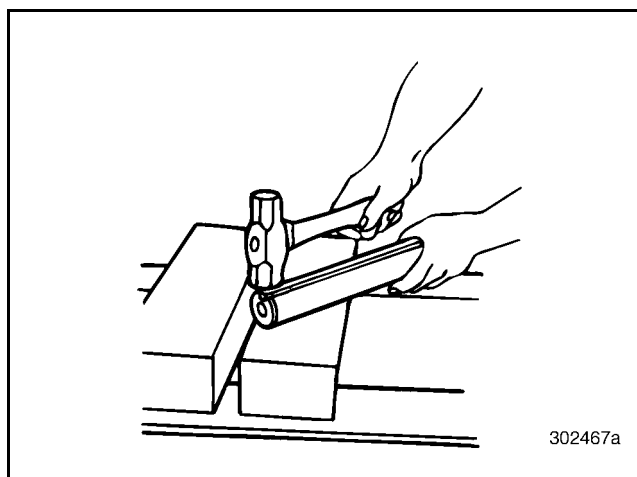

Figure 248 — Installing Key



REPAIR INSTRUCTIONS

- Press the third (8th) speed gear onto the shaft approximately 2–3 inches from the front end of the shaft to start. Do not exceed three inches at this time. The next two gears will press this gear to the proper location.

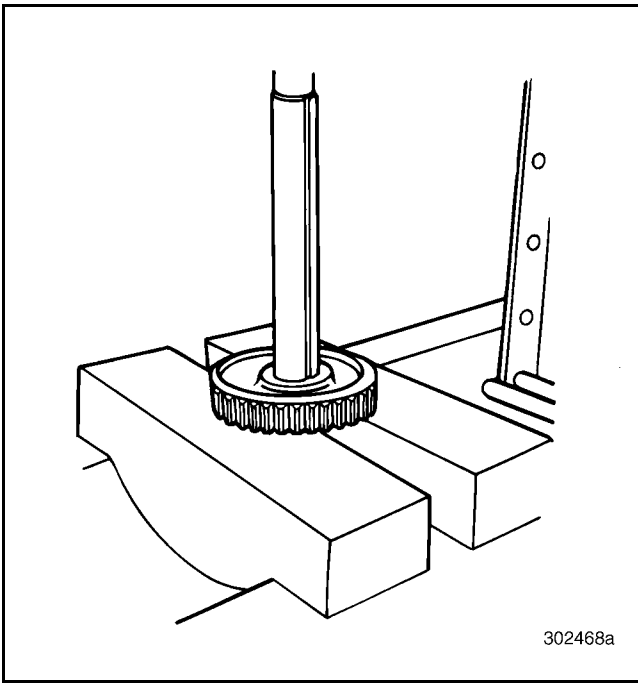

Figure 249 — Pressing Third Speed Gear onto Shaft

- Press the fifth (10th) speed gear onto the shaft approximately 2-1/4 inches from the front end of the shaft to start.

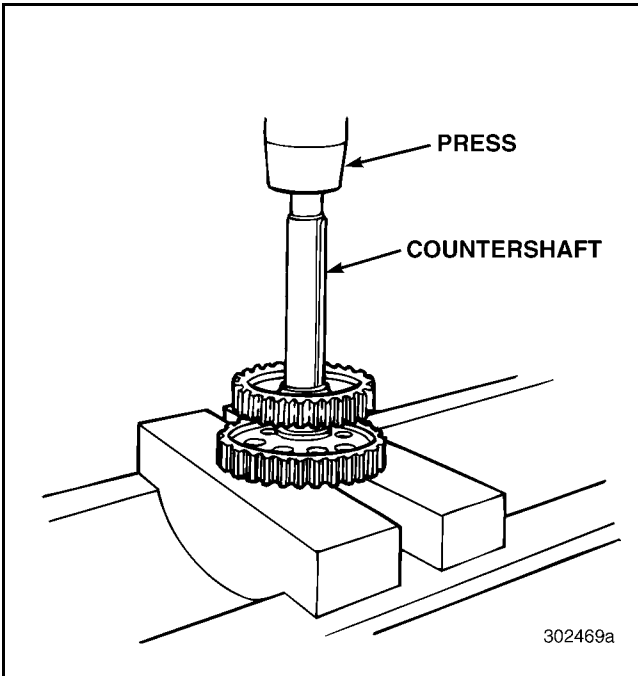

Figure 250 — Pressing Fifth Speed Gear onto Shaft

NOTE

For the remaining pressing operations on this countershaft assembly, use a driver or other pressing tool that covers the end of the shaft and part of the main drive gear hub front surface. See Figure 251 for tool dimensions.

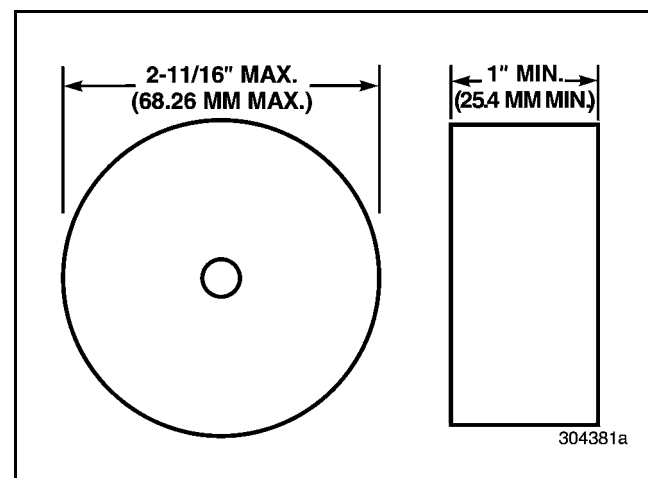

Figure 251 — Pressing Tool Dimensions

- Press the main drive gear onto the front of the countershaft with the protruding hub of the gear facing rearward. Using a suitable pressing tool for support, press until the end of the shaft is exactly flush with the gear hub front surface.

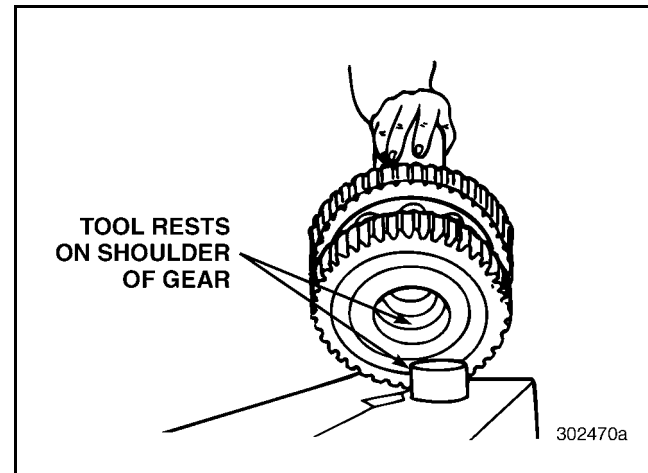

Figure 252 — Main Drive Gear Pressed Flush onto Shaft (Driver or Press Tool Keeps Shaft and Gear Even)



REPAIR INSTRUCTIONS

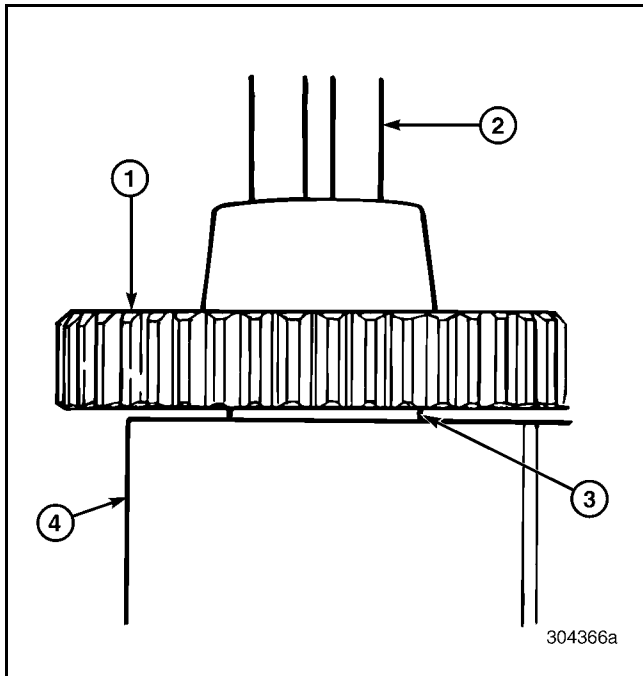

Figure 253 — Supporting Main Drive Gear and Shaft

- | | |
|--------------------|------------------|
| 1. Main Drive Gear | 3. Pressing Tool |
| 2. Countershaft | 4. Support Block |

- Position the front end of the shaft on the driver (press tool), to maintain evenness of the shaft, during steps 7 through 11.
- Install the longer (front) spacer onto the shaft next to the third (8th) speed gear and then press the second (7th) speed gear onto the shaft from the rear. Press until gear seats and compresses spacer against the third (8th) speed gear.

⚠ DANGER

Do not attempt to press the reverse, first or second speed gears onto the front end of the countershaft. The front end of the shaft is slightly larger in diameter than the rear of the shaft. Attempting to press any of these three gears onto the front end of the shaft can cause the gears to crack and fragment explosively, and cause personal injury or death.

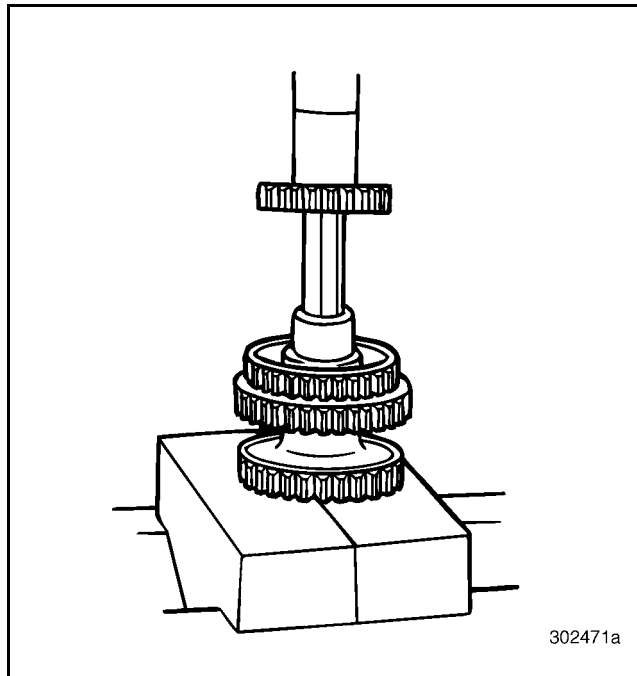

Figure 254 — Pressing Second Speed Gear onto Shaft

- Press the first (6th) speed gear onto the shaft until seated against the second speed gear.

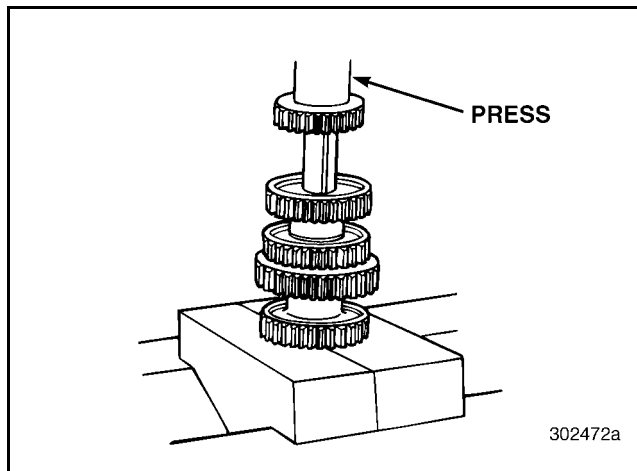

Figure 255 — Pressing First Speed Gear onto Shaft



REPAIR INSTRUCTIONS

9. Install the shorter (rear) spacer onto the shaft next to the first speed gear.

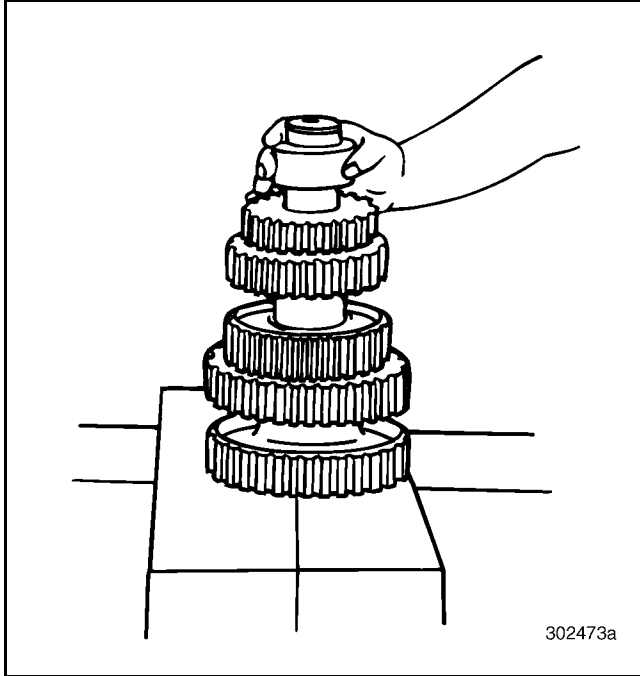

Figure 256 — Installing Rear Spacer onto Shaft

10. Press the reverse speed gear onto the shaft until the spacer is compressed against the first speed gear. Install the gear with the recess facing the rear end of the shaft. The recess allows full installation of the rear bearing cone.

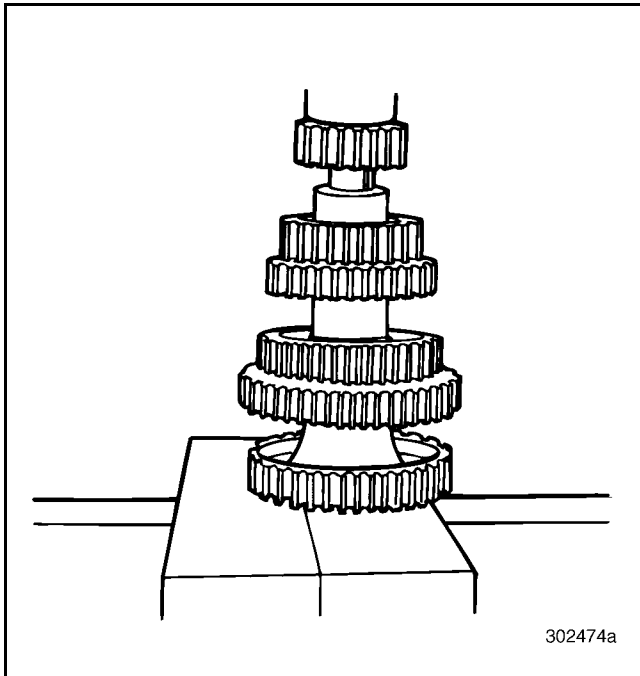

Figure 257 — Pressing Fifth Speed Gear onto Shaft

11. Press the bearing cone onto the rear end of the shaft, using a suitable driver. Apply force only to the inner race of the bearing cone. Press the bearing until seated against the surface of the reverse speed gear.

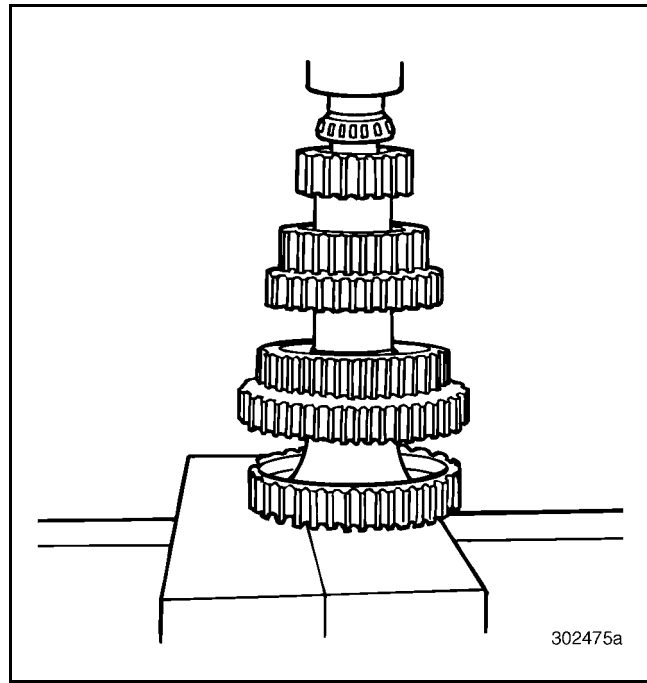

Figure 258 — Pressing Rear Bearing Cone onto Shaft

Front Countershaft Front Bearing Cover Reassembly [321]

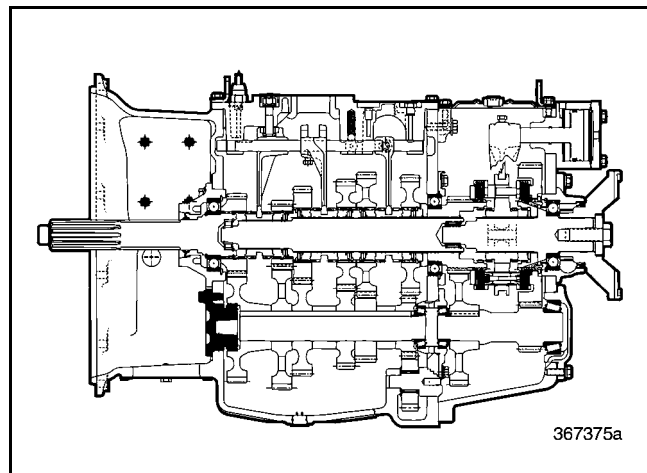

Figure 259 — Front Countershaft Front Bearing Cover Component Locator



REPAIR INSTRUCTIONS

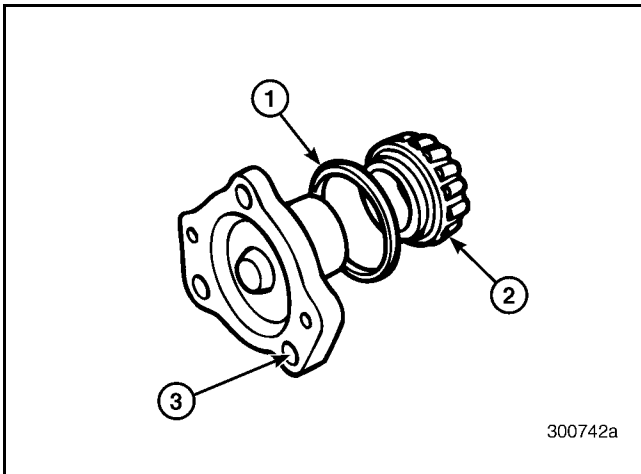

Figure 260 — Exploded View of Front Countershaft Front Bearing Cover

1. O-Ring	3. Front Bearing Cover
2. Bearing Cone	

The following reassembly procedure applies to all three front countershaft front bearing covers.

1. Press the bearing cone onto the front countershaft front bearing cover, using a suitable driver. Apply force to the inner race of the bearing only.

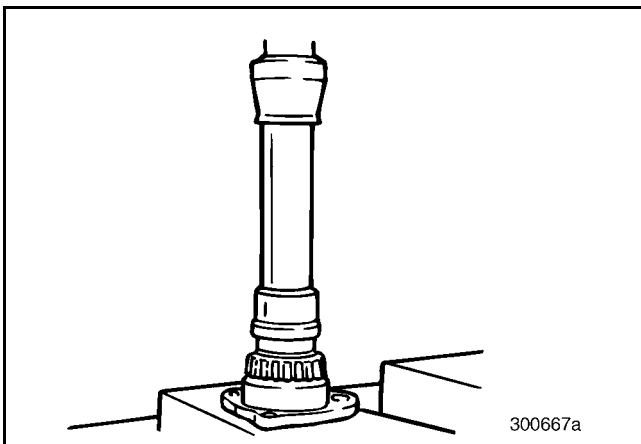

Figure 261 — Pressing Bearing Cone onto Cover

2. Install a **new** O-ring onto the shoulder of the front bearing cover.

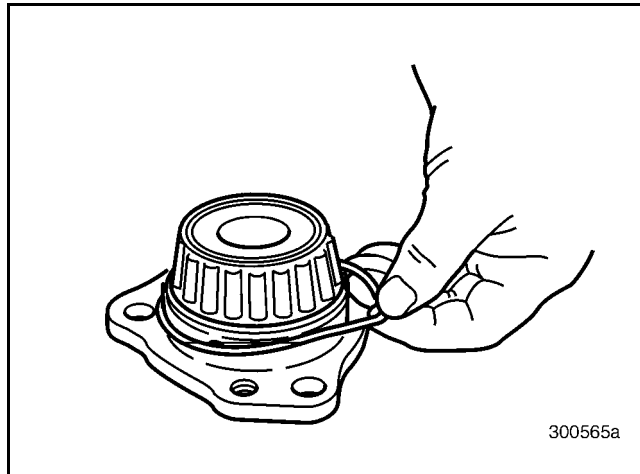

Figure 262 — Installing O-Ring onto Front Cover

Compound Main Drive Gear Reassembly [322]

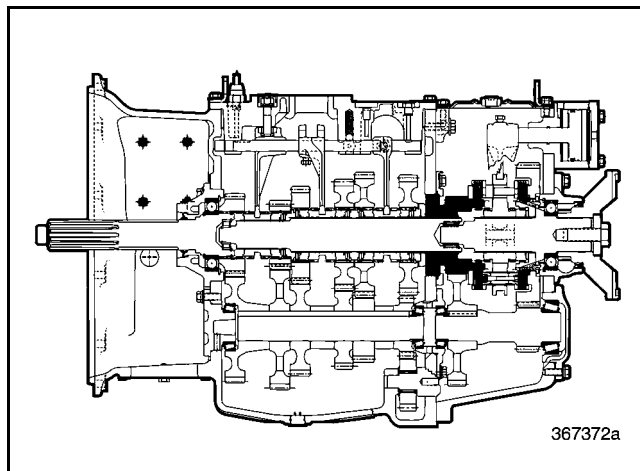

Figure 263 — Compound Main Drive Gear Component Locator



REPAIR INSTRUCTIONS

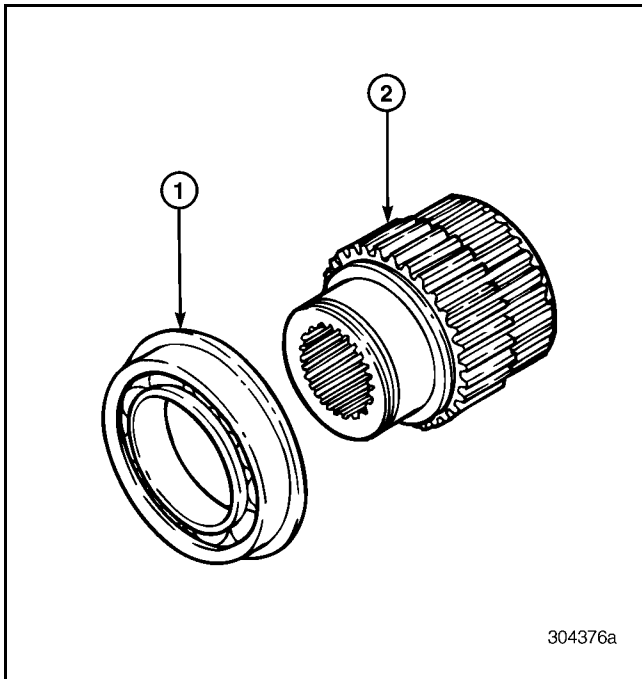

Figure 264 — Exploded View of Compound Main Drive Gear

- | | |
|--------------------------|--------------------|
| 1. Bearing and Snap Ring | 2. Main Drive Gear |
|--------------------------|--------------------|

1. Press the bearing onto the compound main drive gear, using a suitable driver. Apply force to the inner race of the bearing only.

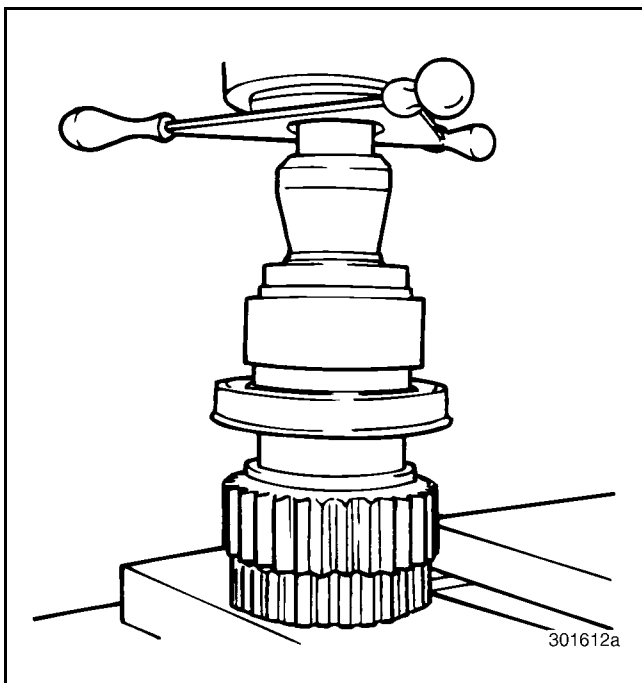

Figure 265 — Pressing Bearing onto Main Drive Gear

2. Set the compound main drive gear and bearing assembly aside for later installation.

Rear Mainshaft Bearing Cover Reassembly [321]

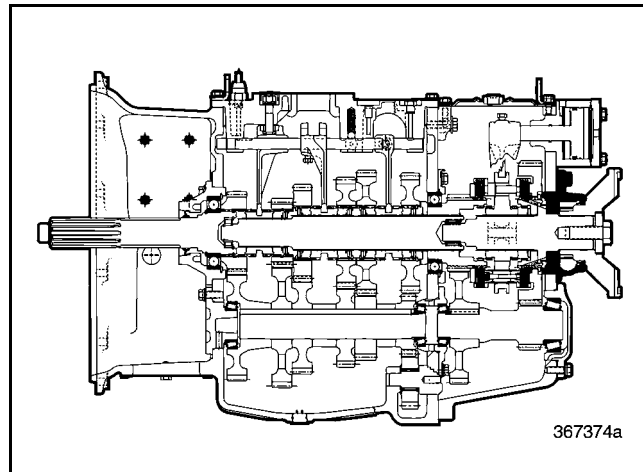

Figure 266 — Rear Mainshaft Bearing Cover Component Locator

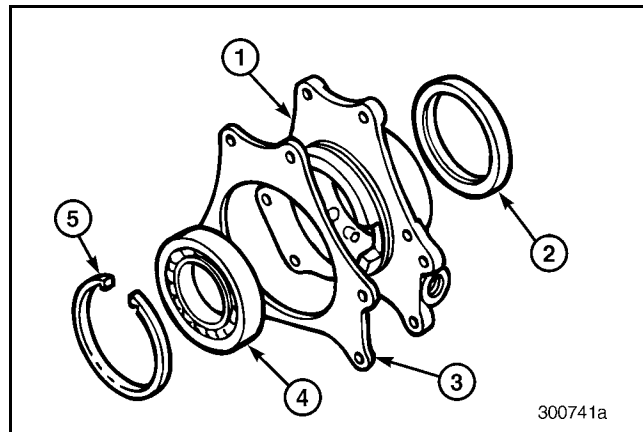

Figure 267 — Exploded View of Rear Mainshaft Bearing Cover

- | | |
|------------------|--------------|
| 1. Bearing Cover | 4. Bearing |
| 2. Oil Seal | 5. Snap Ring |
| 3. Gasket | |



REPAIR INSTRUCTIONS

1. Press a **new** oil seal into the rear mainshaft bearing cover. Refer to Oil Seals in "INSPECTION OF PARTS" on page 95 for installation instructions.

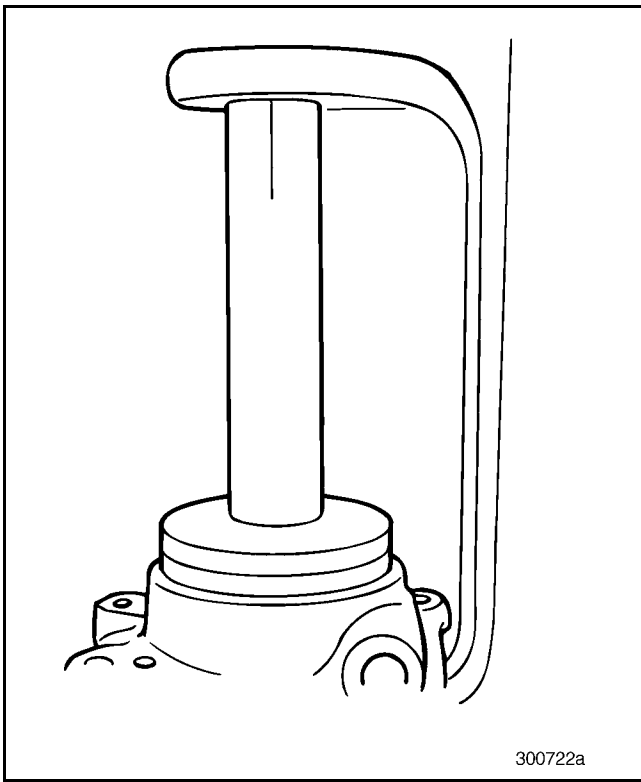

Figure 268 — Pressing Oil Seal into Rear Mainshaft Bearing Cover

2. Press the bearing into the cover, using a suitable driver. Apply force to the outer race only.

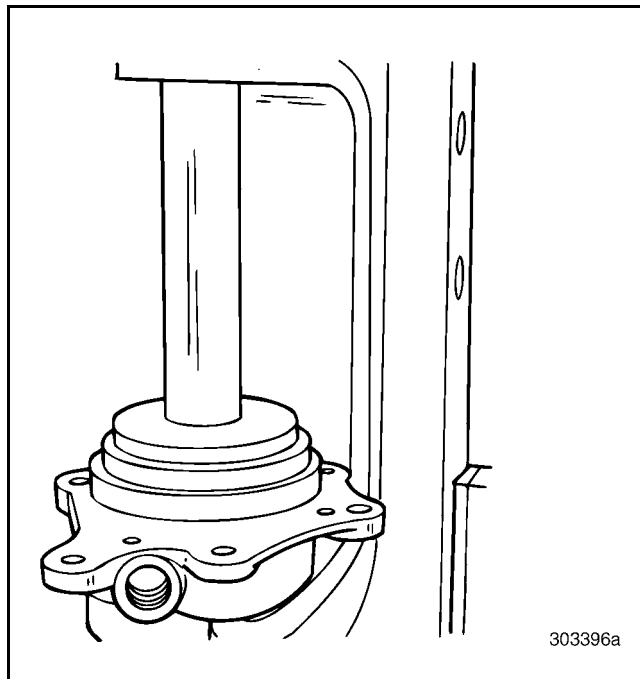

Figure 269 — Pressing Bearing into Bearing Cover

3. Install the snap ring securing the bearing in the rear mainshaft bearing cover, using suitable snap ring pliers.

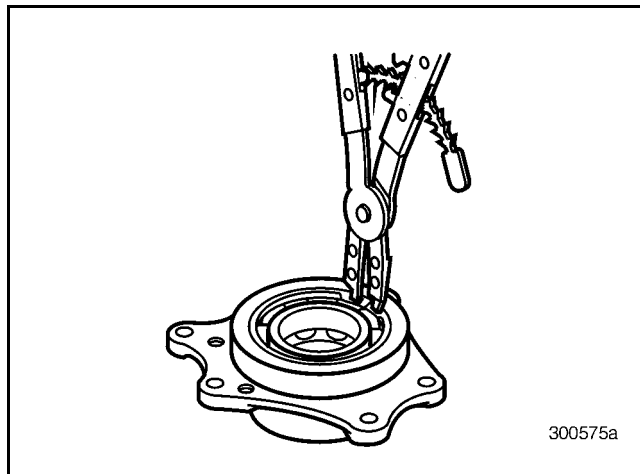

Figure 270 — Installing Snap Ring



REPAIR INSTRUCTIONS

4. Install a **new** rear mainshaft bearing cover gasket. Make sure the oil passageways in the gasket line up with the oil passageways in the cover.

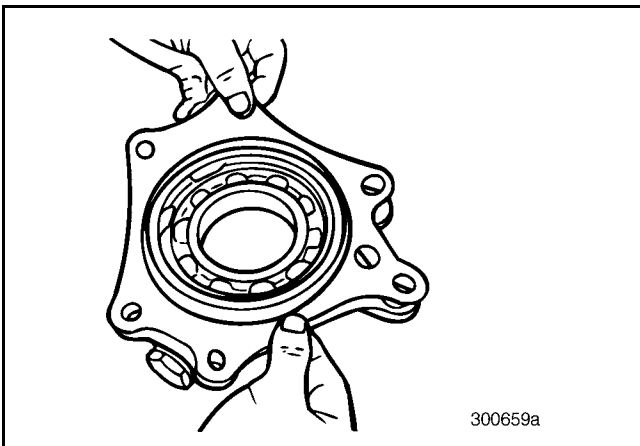

Figure 271 — Installing Gasket onto Cover

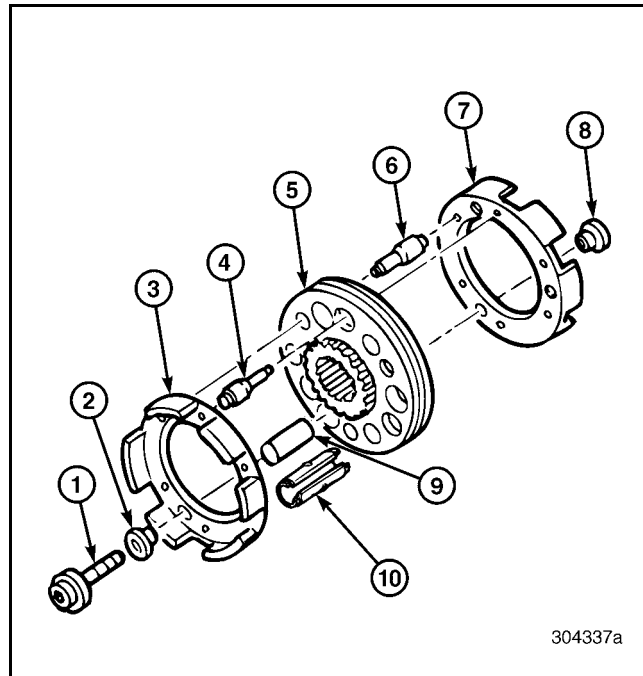

Figure 273 — Exploded View of Synchronizer

Synchronizer Reassembly [322]

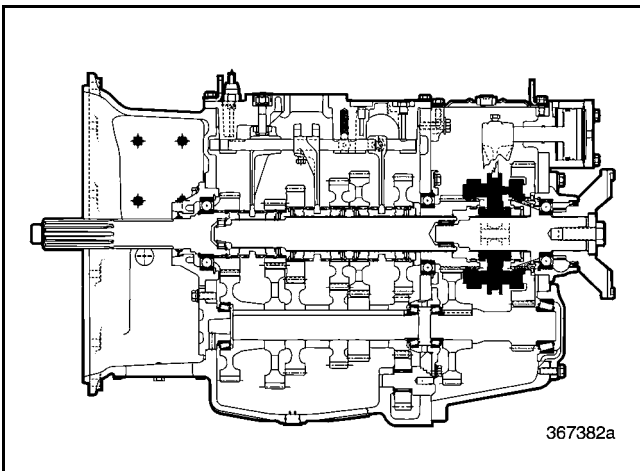

Figure 272 — Synchronizer Component Locator

- | | |
|-----------------------|---------------------|
| 1. 12-Point Screw | 6. Synchronizer Pin |
| 2. Nonthreaded Insert | 7. Clutch Housing |
| 3. Clutch Housing | 8. Threaded Insert |
| 4. Synchronizer Pin | 9. Support Tube |
| 5. Sliding Clutch | 10. Preload Spring |



REPAIR INSTRUCTIONS

1. Install the synchronizer pins into one of the two identical synchronizer clutch housings. Install the pins with the marked letter "R" facing up. Alternate pin heads as shown.

NOTE

As you install the pins, notice that the pins and the sliding clutch are marked with the letter "R", which stands for "Rear." All the R marks on either end of the pins are placed on the same side of the sliding clutch marked with the letter R. During reassembly, make sure to coordinate all R marks on both the pins and sliding clutch of the synchronizer assembly. All R marks must face the rear of the transmission when installed.

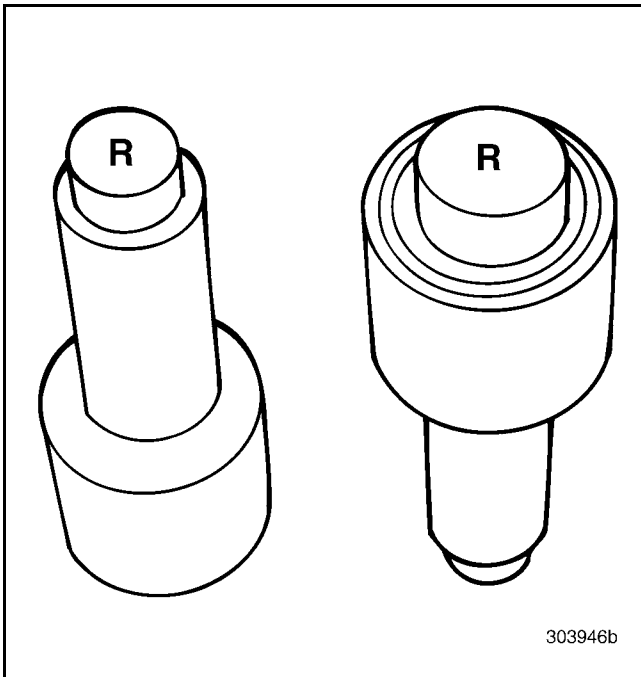

Figure 274 — Synchronizer Pins Showing "R" Marks

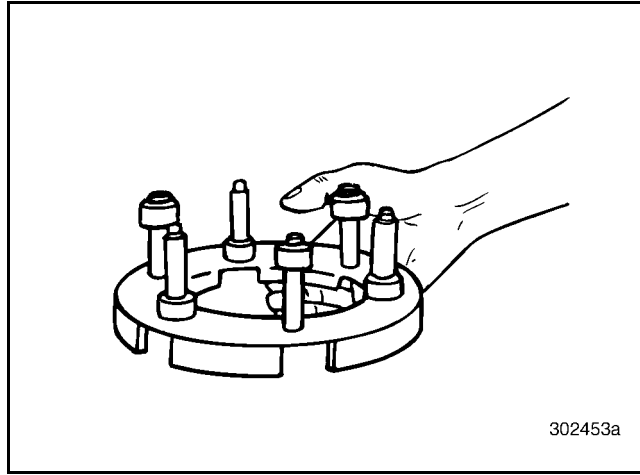

Figure 275 — Installing Synchronizer Pins

2. The three synchronizer preload springs are made up of two pieces. Make sure that the preload springs are assembled with the smooth-sided inner portion of the spring inside the notched (detent) outer portion of the spring.

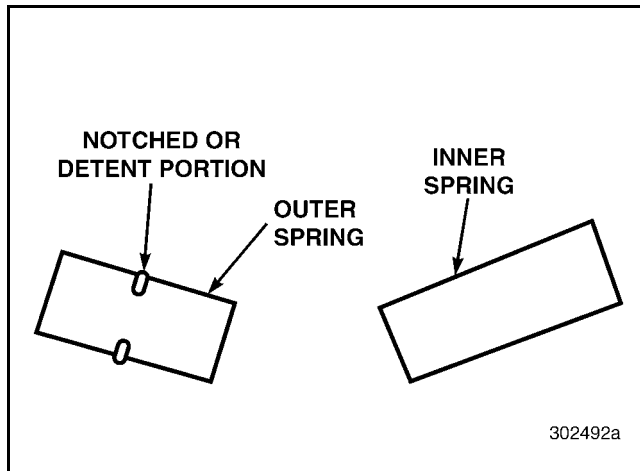

Figure 276 — Assembling Preload Springs



REPAIR INSTRUCTIONS

- Position the synchronizer sliding clutch on the bench with the marked letter R facing up. Install the three preload springs into the sliding clutch holes provided. The smaller holes are ramped and found halfway between the three largest holes.

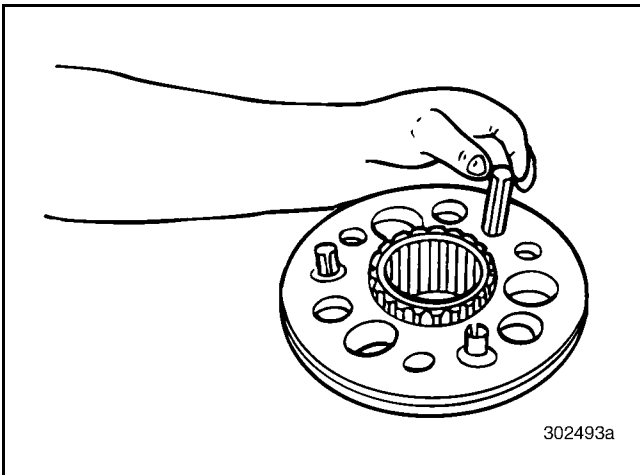

Figure 277 — Installing Preload Springs into Sliding Clutch

- Install the sliding clutch (with preload springs) over the synchronizer clutch housing and pins. Make sure the marked letter R on the clutch is facing in the same direction as the R marked on the pins.

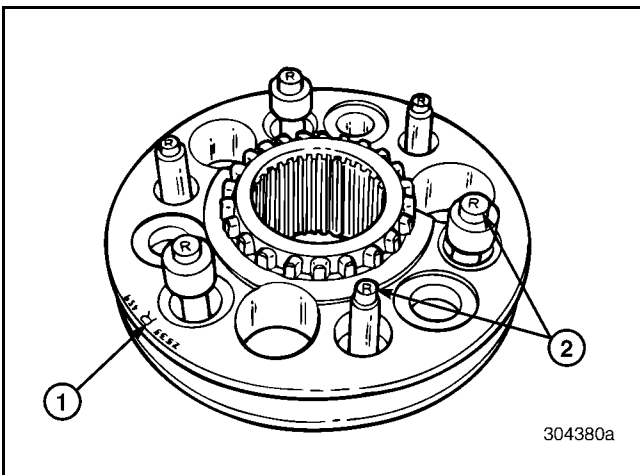

Figure 278 — Synchronizer Pins and Sliding Clutch Showing "R" Marks (Preload Springs Removed for Clarity)

1. "R" on Sliding Clutch, Faces Rearward	2. "R" on Synchronizer Pins, Faces Rearward
--	---

NOTE

With this sliding clutch design, it is very important to make sure that the clutch is facing in the correct direction when installed. This is due to the differing number of clutch teeth on the Lo-range and Hi-range sides of the range clutch. The Lo-range side contains 21 clutching teeth and the Hi-range side contains 22 clutching teeth. Incorrectly installing the sliding clutch prevents proper shifting.

- Install the three support tubes into the synchronizer assembly.

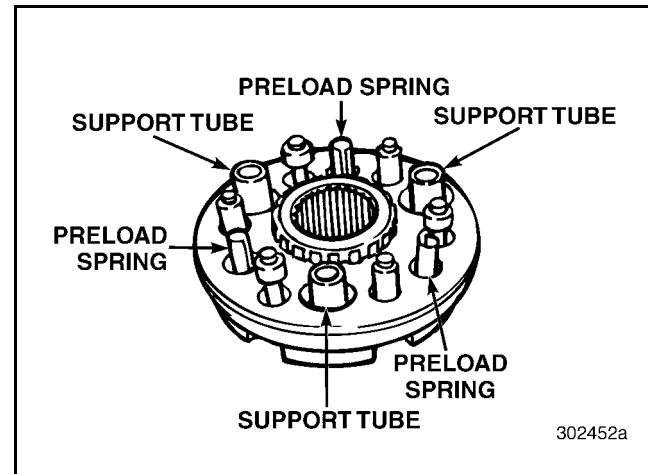

Figure 279 — Install Support Tubes into Assembly

- Install the remaining synchronizer housing over the pins, tubes and springs. Align the housing with the pin heads.
- Install the three 12-point screws, plus threaded and nonthreaded inserts into the largest holes of the synchronizer assembly.

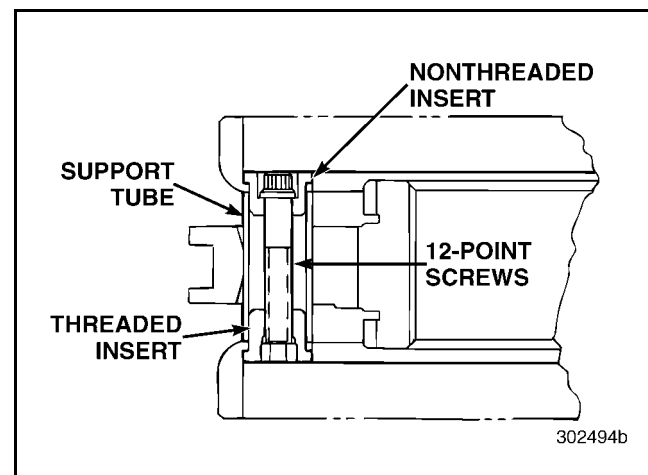

Figure 280 — Installing 12-Point Screws and Inserts



REPAIR INSTRUCTIONS

8. Tighten the three 12-point screws to specification, using a suitable hex wrench to hold the threaded inserts.

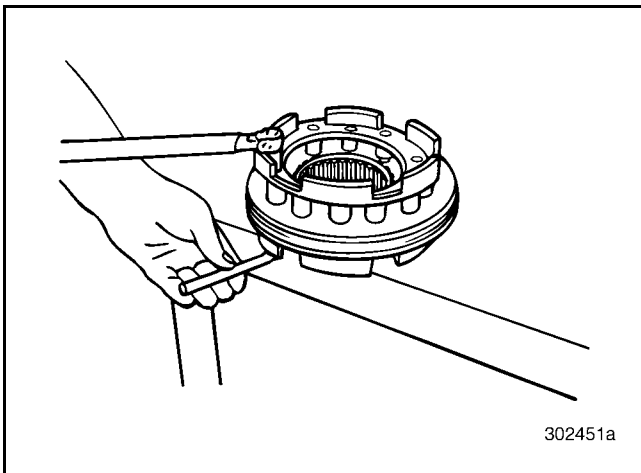

Figure 281 — Tightening 12-Point Screws

Rear Mainshaft Reassembly [322]

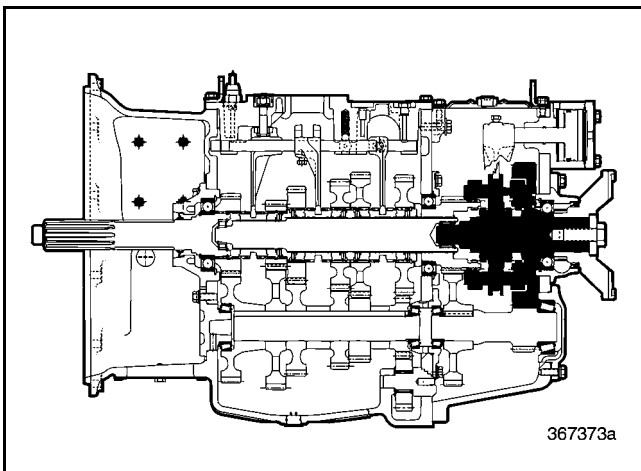

Figure 282 — Rear Mainshaft Component Locator

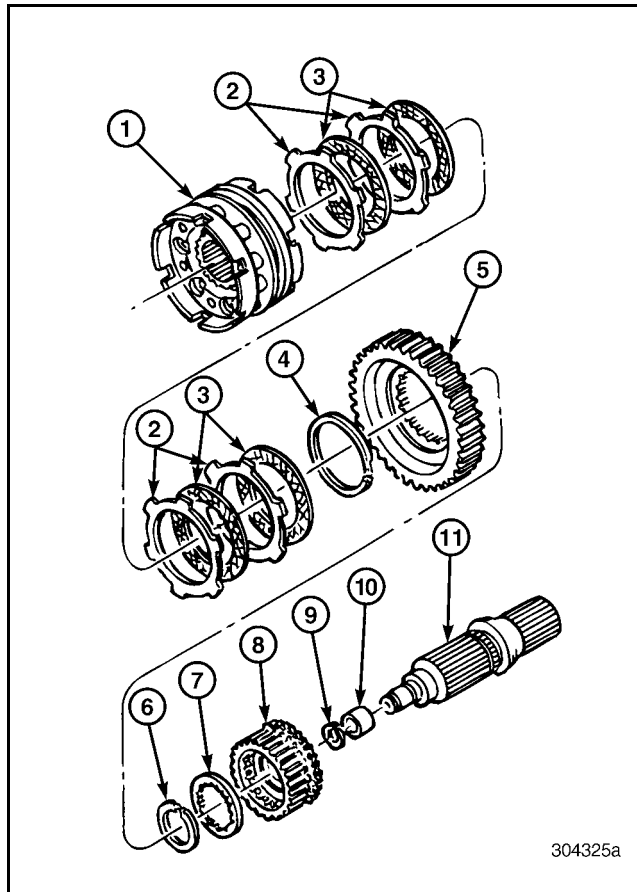

Figure 283 — Exploded View of Rear Mainshaft and Synchronizer Assembly

- | | |
|--------------------------|-----------------------------------|
| 1. Synchronizer Assembly | 7. Internal-Toothed Thrust Washer |
| 2. Reaction Discs | 8. Lo-Range Gear Hub |
| 3. Friction Discs | 9. Snap Ring |
| 4. Snap Ring | 10. Spigot Bearing Inner Race |
| 5. Lo-Range Gear | 11. Rear Mainshaft |
| 6. Snap Ring | |



REPAIR INSTRUCTIONS

1. Press a **new** spigot bearing inner race onto the front end of the rear mainshaft and secure it with the retaining snap ring.

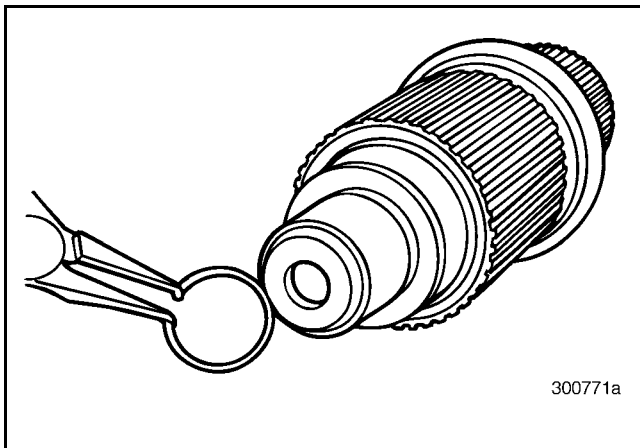

Figure 284 — Installing Snap Ring

2. Install the Lo-range gear hub onto the rear mainshaft.

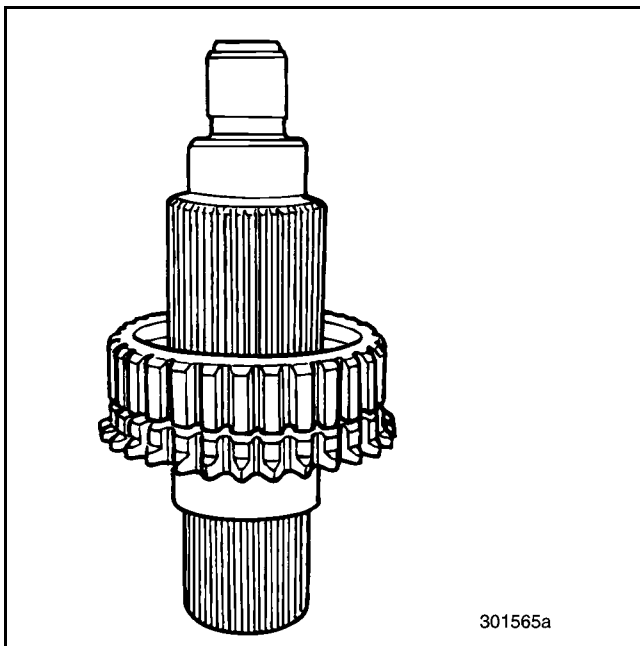

Figure 285 — Installing Lo-Range Gear Hub

3. Install the gear hub thrust washer over the rear mainshaft, against the hub.

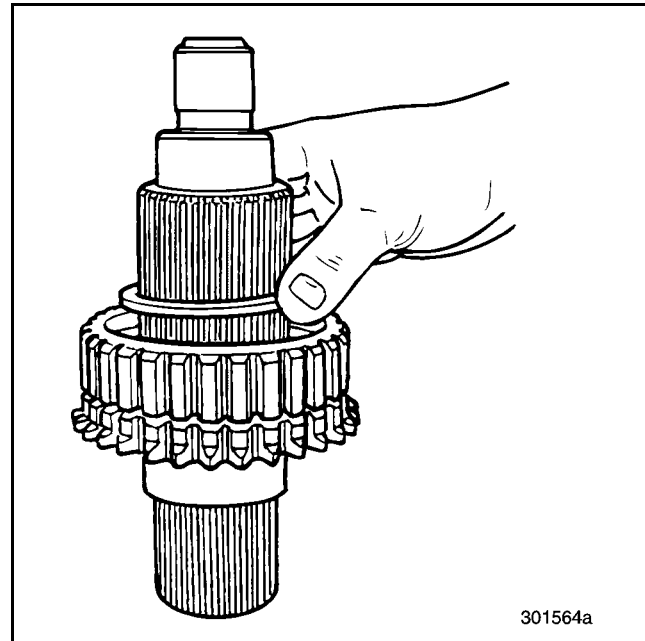

Figure 286 — Installing Gear Hub Thrust Washer

4. Install the Lo-range gear hub snap ring, using suitable snap ring pliers.

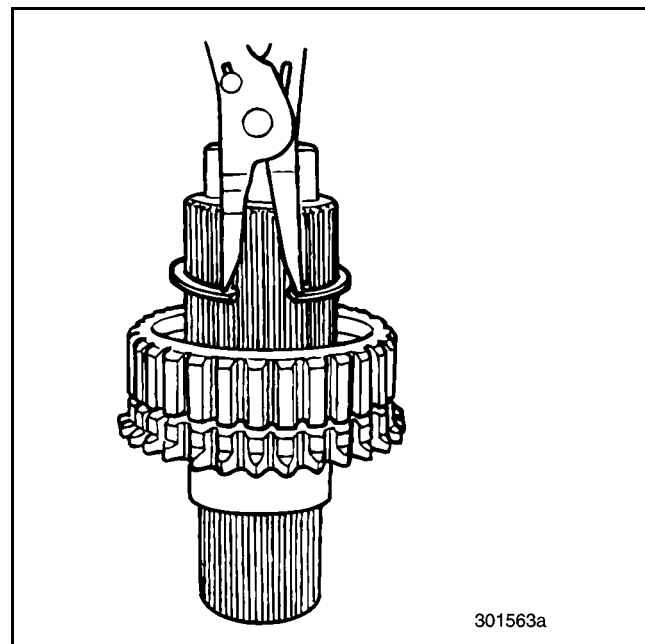

Figure 287 — Installing Gear Hub Snap Ring



REPAIR INSTRUCTIONS

5. Install the Lo-range gear over the gear hub with friction disc surface of gear facing up.

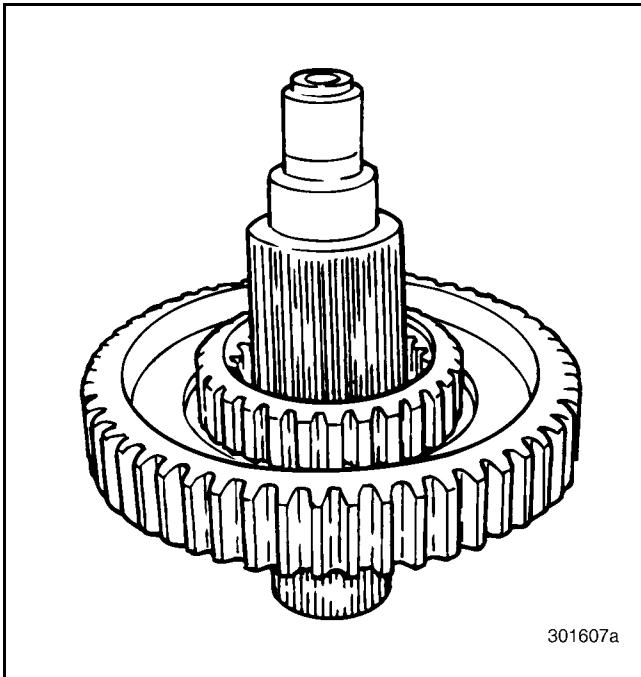

Figure 288 — Installing Lo-Range Gear

6. Install the spiral snap ring to secure the Lo-range gear to the gear hub.

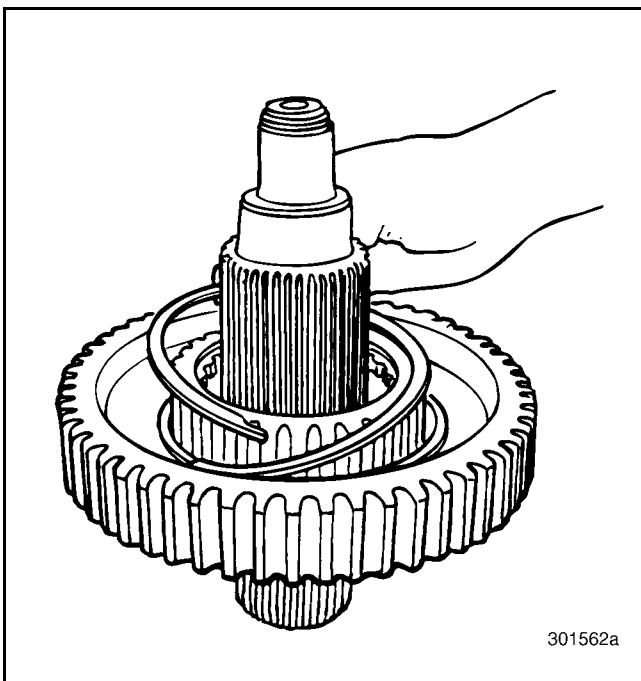

Figure 289 — Installing Spiral Snap Ring

7. Lubricate all synchronizer friction and reaction discs, using the recommended lubricant.

NOTE

Before and during installation, make sure to lubricate all synchronizer friction and reaction discs and associated parts (gear and gear hub), using the recommended lubricant. This prevents premature wear to the individual parts of the synchronizer assembly during initial transmission start-up.

8. Install the first friction disc into the Lo-range gear.

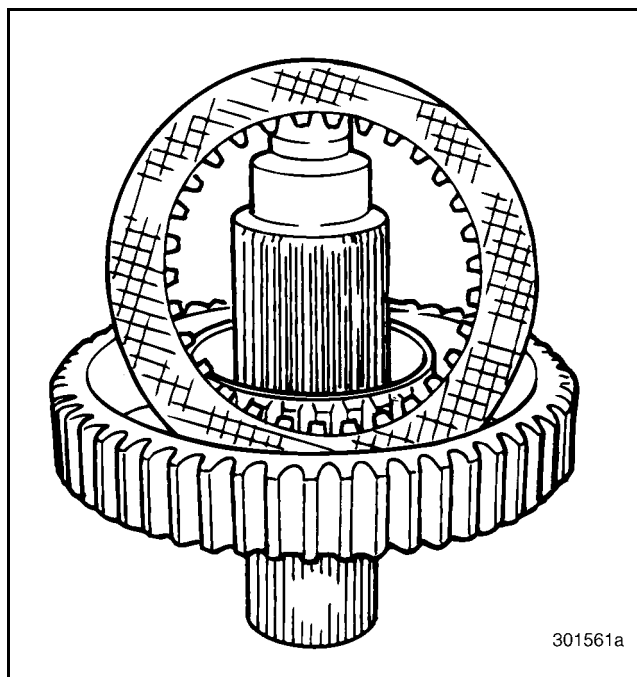

Figure 290 — Installing Friction Disc



REPAIR INSTRUCTIONS

9. Install the first reaction disc onto the friction disc just installed.

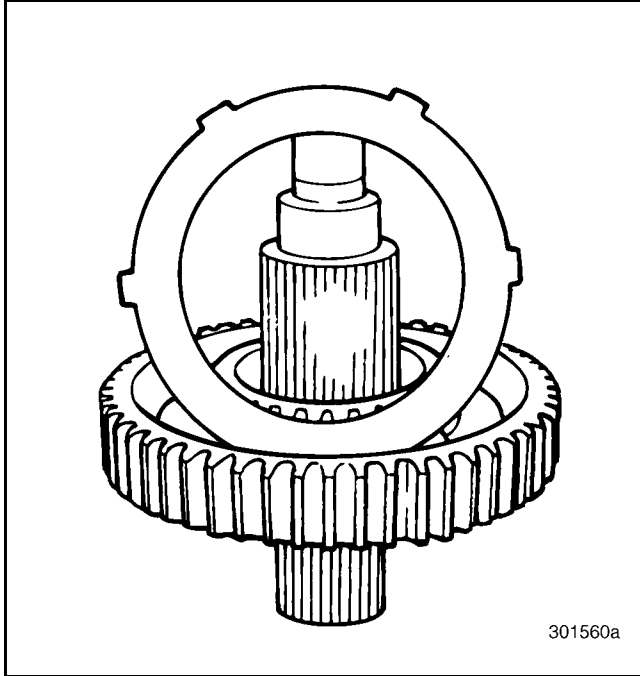

Figure 291 — Installing Reaction Disc

10. Continue adding alternating friction and reaction discs into the Lo-range gear until four of each have been installed.

11. Align the tangs of the reaction discs and then install the synchronizer assembly over the rear mainshaft. Engage the slots of the synchronizer clutch housing with the tangs of all four reaction discs.

NOTE

Make sure that the synchronizer assembly is installed with the R markings on the clutch and pins, facing the rear of the mainshaft, against the discs just installed.

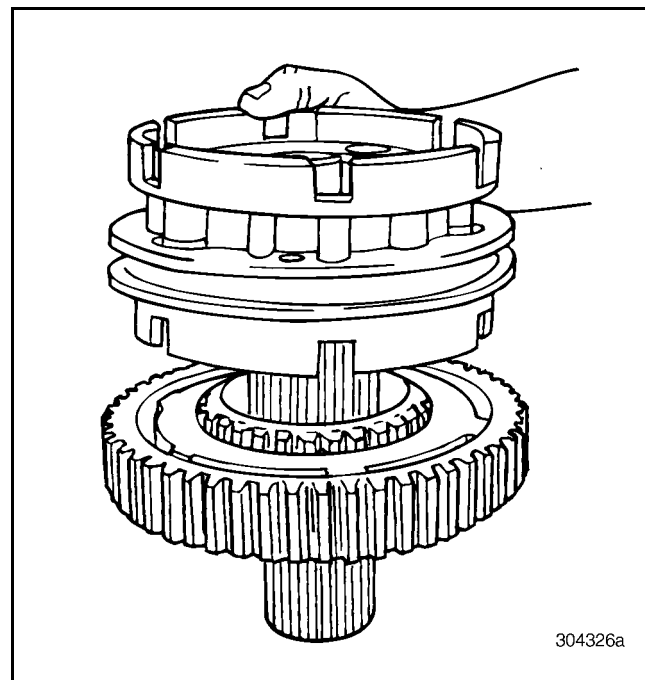

Figure 292 — Installing Synchronizer Assembly



REPAIR INSTRUCTIONS

Front Mainshaft Reassembly [322]

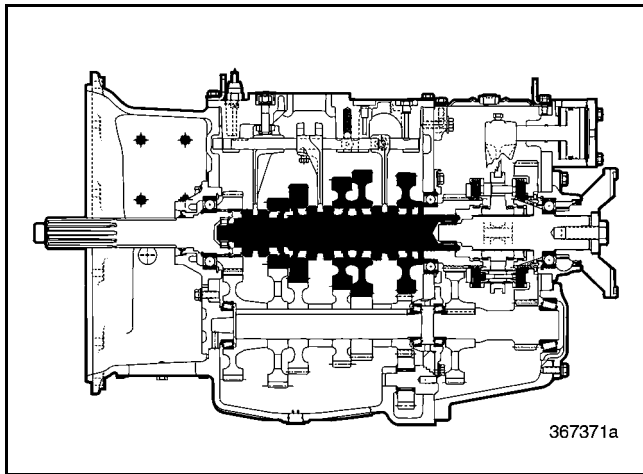

Figure 293 — Front Mainshaft Component Locator

The splines on the mainshaft are usually not aligned for the whole length of the shaft. The recommended procedure is to install the second, third and fifth speed gears, gear thrust washers and snap rings, and second/third sliding clutch onto the front of the shaft. Install the remaining reverse and first speed gears and components onto the rear of the shaft.

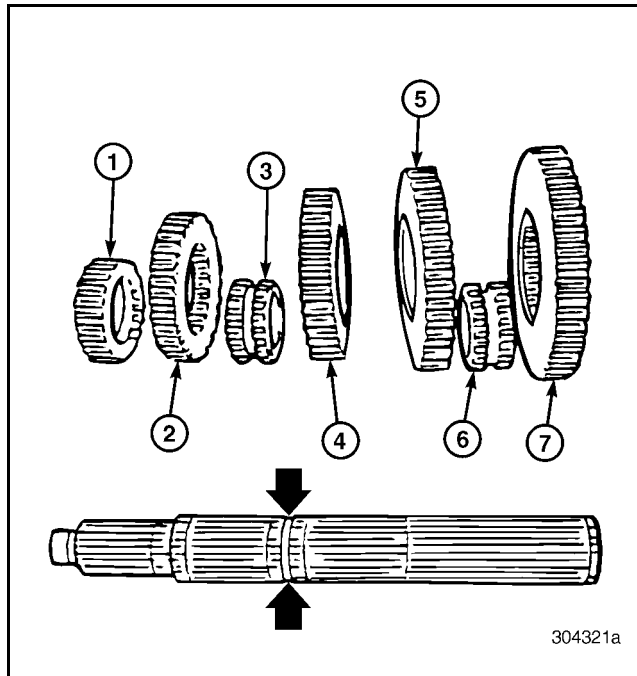
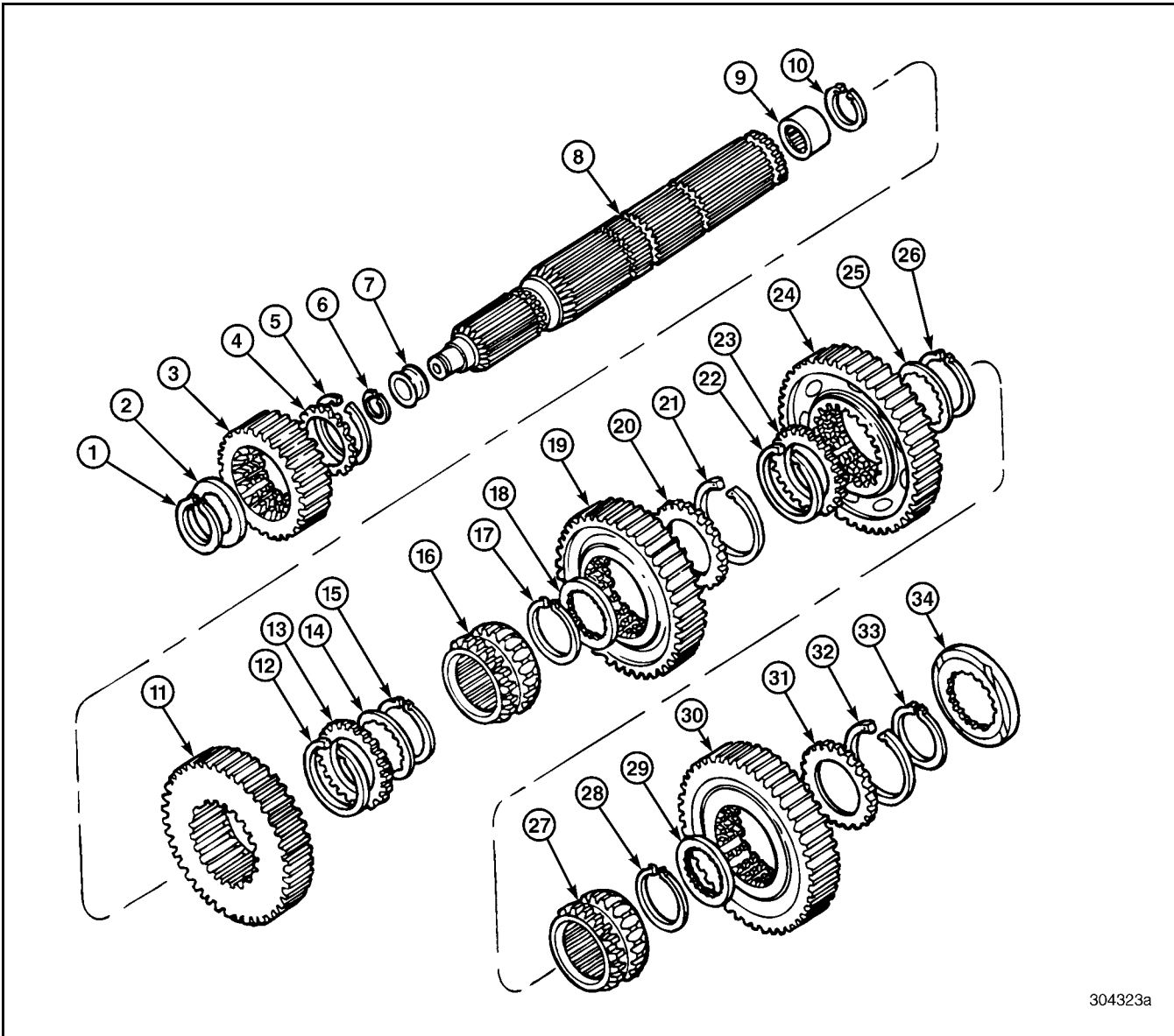

Figure 294 — View of Mainshaft and Gears

- | | |
|----------------------|---------------------|
| 1. Fifth (10th) Gear | 5. First (6th) Gear |
| 2. Third (8th) Gear | 6. Sliding Clutch |
| 3. Sliding Clutch | 7. Reverse Gear |
| 4. Second (7th) Gear | |



REPAIR INSTRUCTIONS



304323a

Figure 295 — Exploded View of Front Mainshaft

1. Mainshaft Snap Ring	12. Gear Snap Ring	24. First (6th) Speed Gear
2. Internal-Toothed Thrust Washer	13. External-Toothed Thrust Washer	25. Internal-Toothed Thrust Washer
3. Fifth (10th) Speed Gear	14. Internal-Toothed Thrust Washer	26. Mainshaft Snap Ring
4. External-Toothed Thrust Washer	15. Mainshaft Snap Ring	27. Sliding Clutch
5. Gear Snap Ring	16. Sliding Clutch	28. Mainshaft Snap Ring
6. Spigot-Bearing Inner Race Snap Ring	17. Mainshaft Snap Ring	29. Internal-Toothed Thrust Washer
7. Spigot-Bearing Inner Race	18. Internal-Toothed Thrust Washer	30. Reverse Speed Gear
8. Front Mainshaft	19. Second (7th) Speed Gear	31. External-Toothed Thrust Washer
9. Spigot Bearing	20. External-Toothed Thrust Washer	32. Gear Snap Ring
10. Spigot Bearing Snap Ring	21. Gear Snap Ring	33. Mainshaft Snap Ring
11. Third (8th) Speed Gear	22. Gear Snap Ring	34. Spacer
	23. External-Toothed Thrust Washer	



REPAIR INSTRUCTIONS

1. Install a **new** spigot bearing inner race onto the front of the mainshaft, using a suitable driver and hammer.

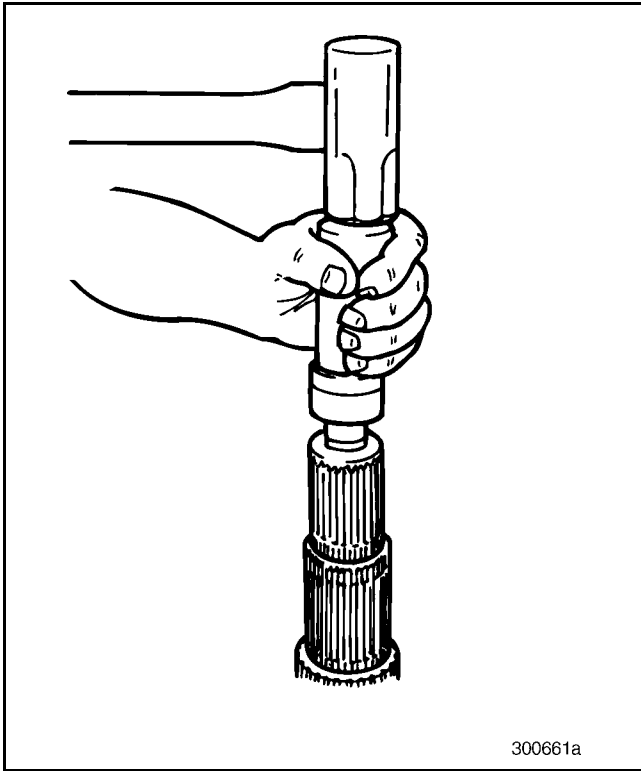

Figure 296 — Installing Spigot Bearing Inner Race

2. Install the inner race snap ring, using suitable snap ring pliers.

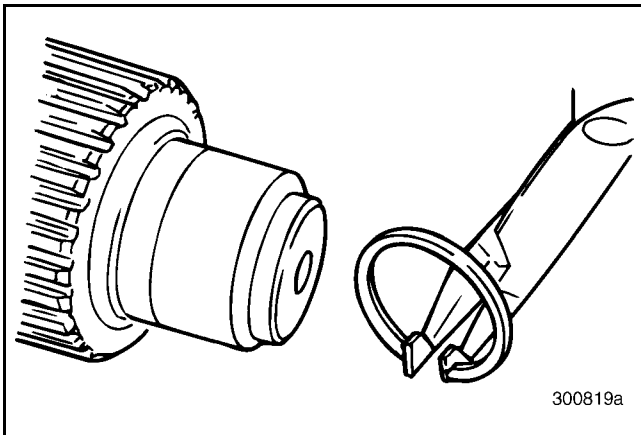

Figure 297 — Installing Inner Race Snap Ring

3. Install a **new** spigot bearing into the rear of the front mainshaft. Use a suitable driver and press that is coaxial with the shaft bore.

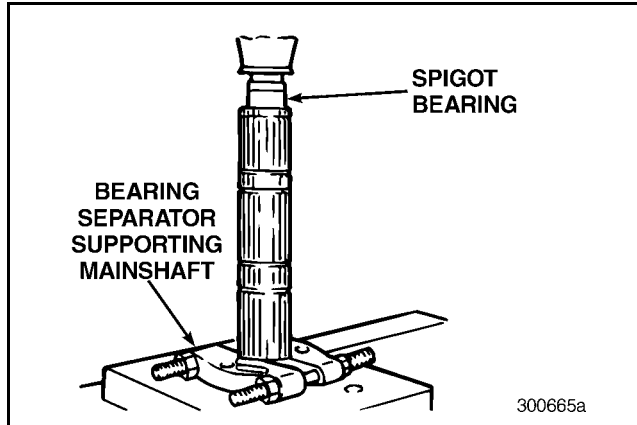

Figure 298 — Installing Spigot Bearing

NOTE

Drawn cup needle bearings (spigot bearings) have a specific direction that they must be installed. The radius end of the bearing is to be installed first. The flat end (the end with identification markings) faces against the angled shoulder of the pressing tool.



REPAIR INSTRUCTIONS

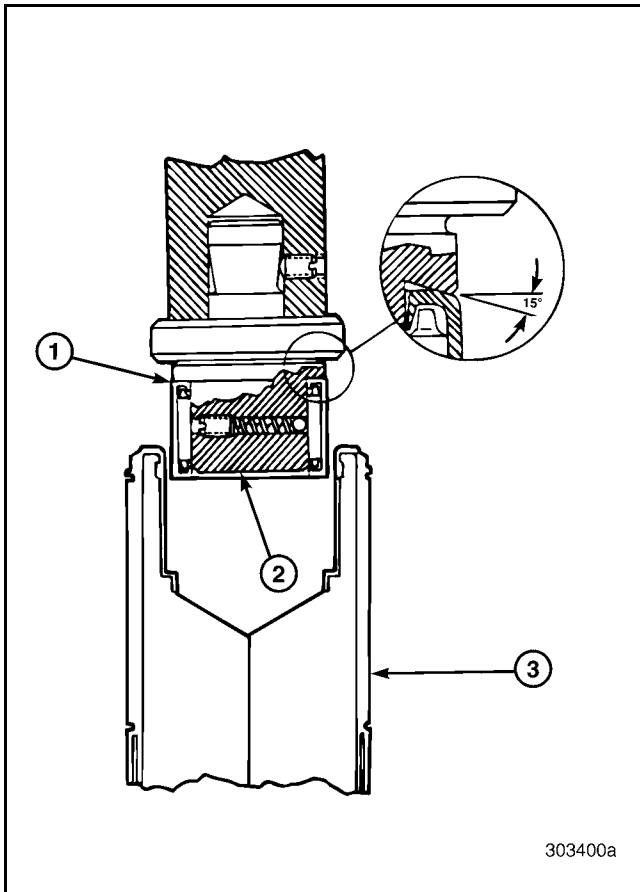

Figure 299 — Installation of Drawn Cup Bearings

- | | |
|-------------------------------|--------------------|
| 1. Stamped End of Bearing | 3. Front Mainshaft |
| 2. Press Tool Leader or Pilot | |

4. Install the front mainshaft spigot bearing retaining snap ring.

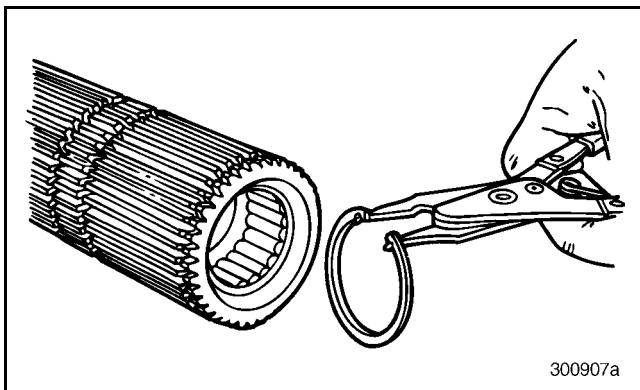

Figure 300 — Installing Spigot Bearing Snap Ring

5. Install the snap ring into the outer groove of the second (7th) speed gear, using suitable snap ring pliers.

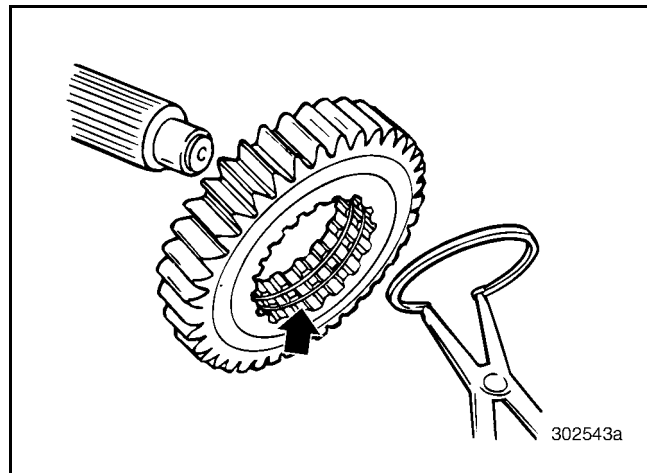

Figure 301 — Installing Snap Ring into Second Speed Gear

6. Working at the front of the mainshaft, install the second (7th) speed gear onto the shaft (clutch teeth face forward).

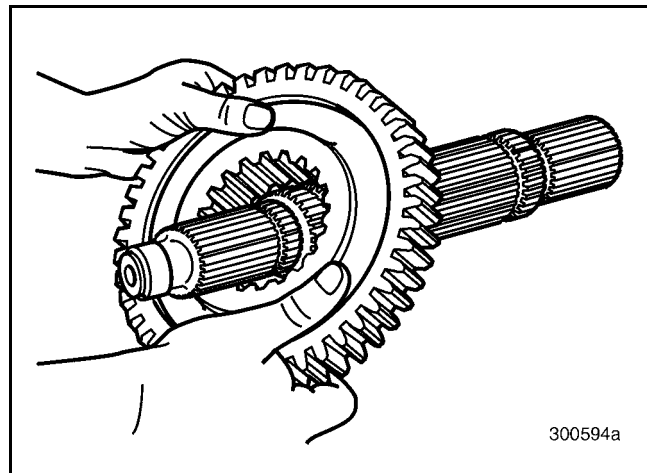

Figure 302 — Installing Second Speed Gear



REPAIR INSTRUCTIONS

7. Install the second (7th) speed gear external- and internal-toothed thrust washers over the mainshaft.

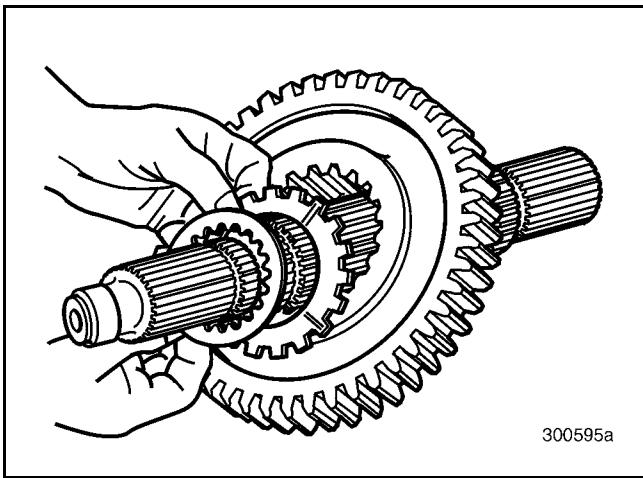

Figure 303 — Installing External- and Internal-Toothed Thrust Washers

8. Install the second (7th) speed gear snap ring into the third groove from the front of the shaft, using suitable snap ring pliers.

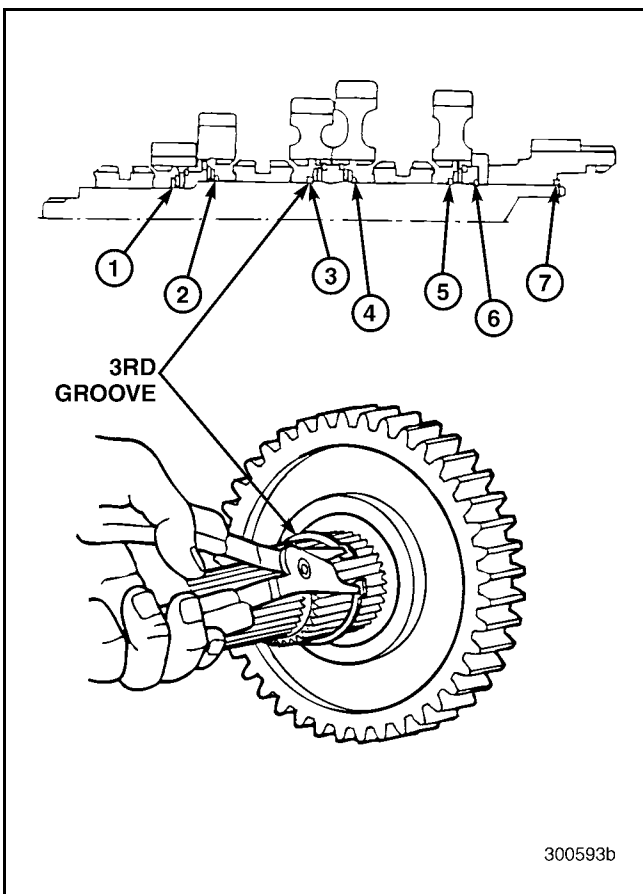

Figure 304 — Installing Second Speed Gear Snap Ring

9. Install the second/third sliding clutch onto the mainshaft.

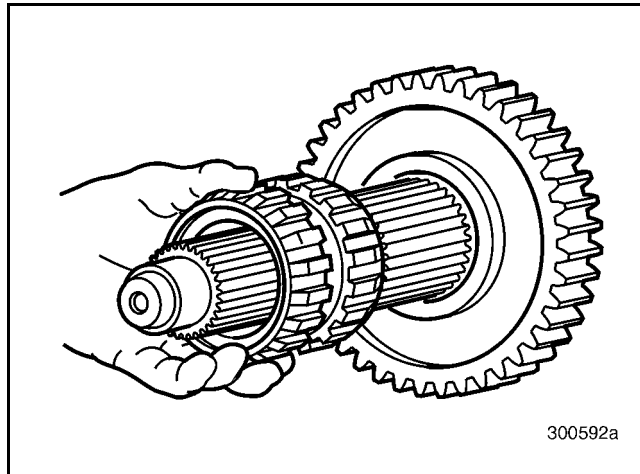

Figure 305 — Installing Second/Third Sliding Clutch

10. Install the third (8th) speed gear mainshaft snap ring into the second groove of the shaft, using suitable snap ring pliers.

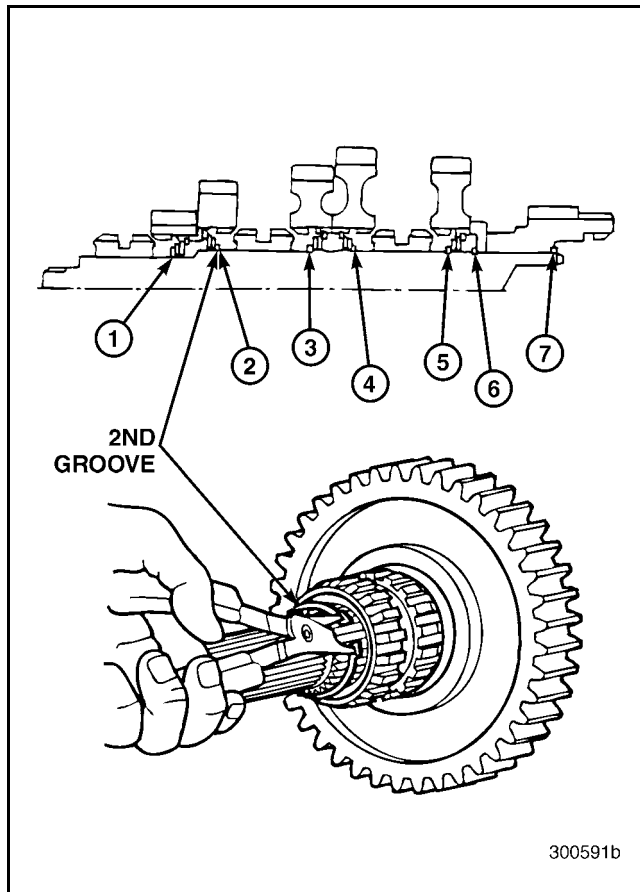

Figure 306 — Installing Third Speed Gear Mainshaft Snap Ring



REPAIR INSTRUCTIONS

11. Install the snap ring into the outer snap ring groove of the third (8th) speed gear, using suitable snap ring pliers.
12. Install the internal-toothed and external-toothed thrust washers, for the third (8th) speed gear, onto the mainshaft. The oil groove side of the external-toothed thrust washer faces rearward.

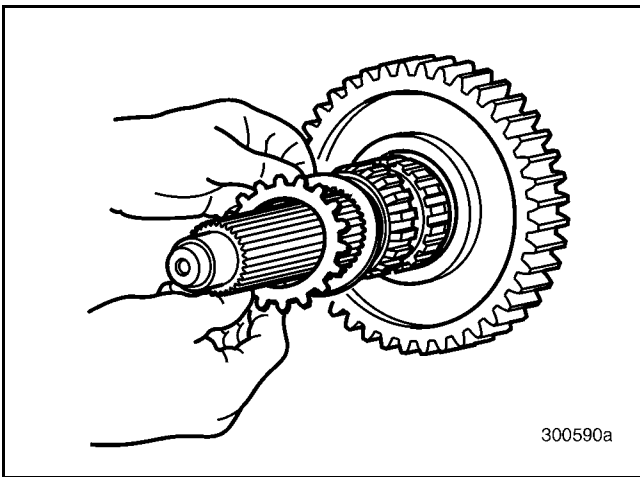

Figure 307 — Installing Internal- and External-Toothed Thrust Washers

13. Install the third (8th) speed gear onto the mainshaft. The clutch teeth on the gear face rearward.

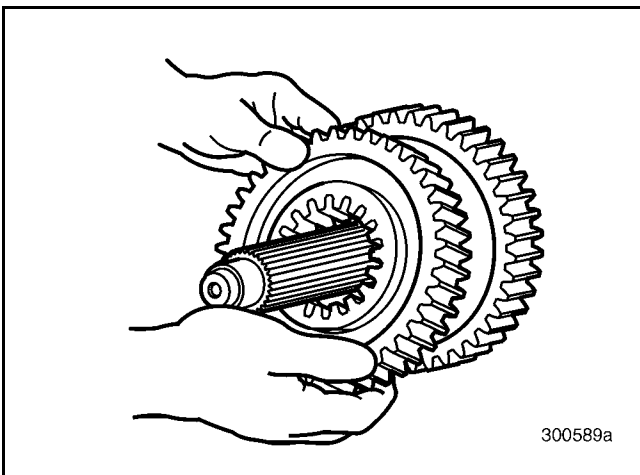

Figure 308 — Installing Third Speed Gear

14. Install the snap ring into the snap ring groove of the fifth (10th) speed gear, using suitable snap ring pliers.

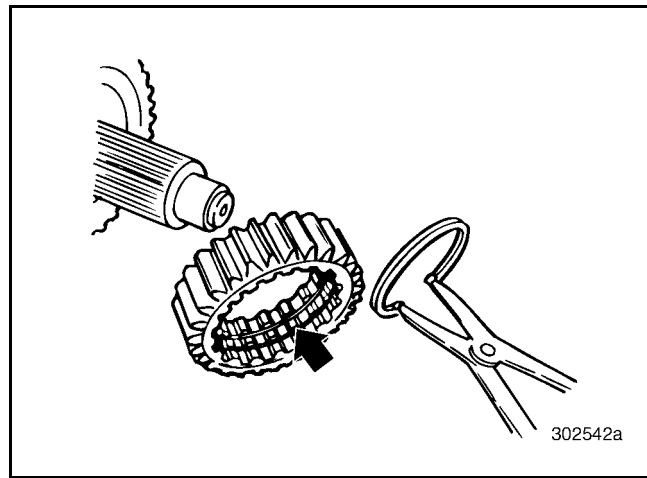

Figure 309 — Installing Snap Ring into Fifth Speed Gear

15. Install the fifth (10th) speed gear and the external-toothed and internal-toothed thrust washers onto the mainshaft with the clutch teeth of the gear facing forward.

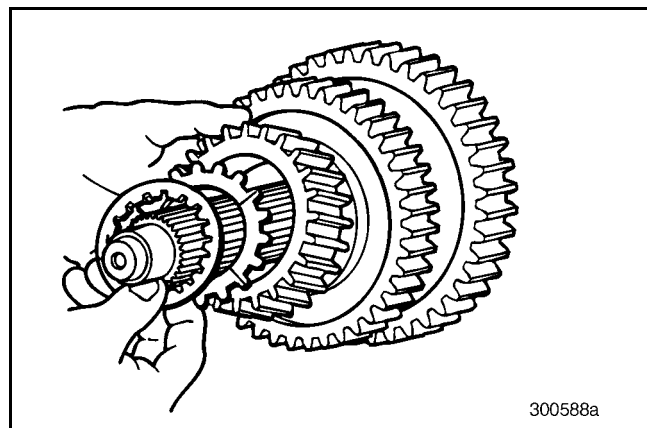

Figure 310 — Installing Fifth Speed Gear and External- and Internal-Toothed Thrust Washers



REPAIR INSTRUCTIONS

16. Install the snap ring on the mainshaft for the fifth (10th) speed gear. Install into first groove from the front.

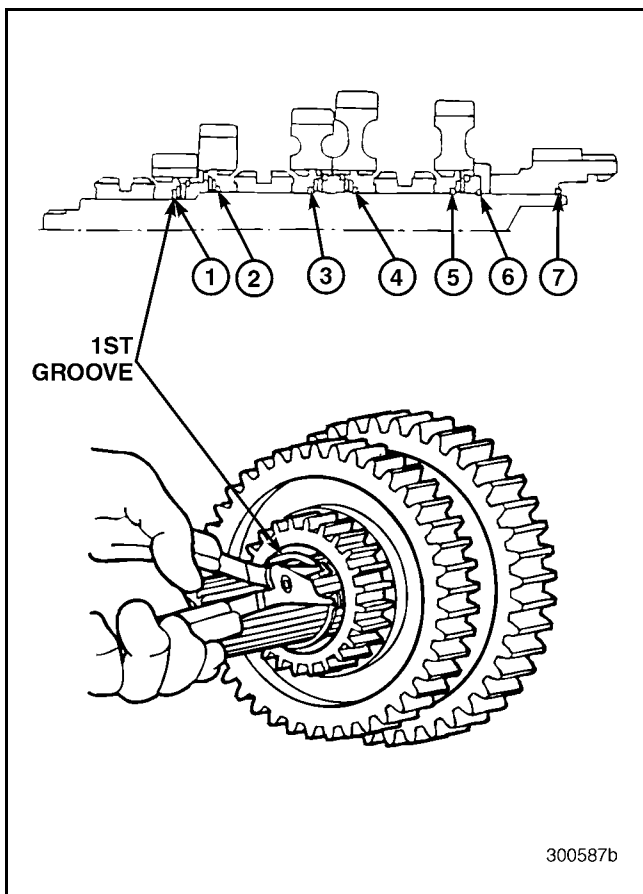

Figure 311 — Installing Fifth Speed Gear Mainshaft Snap Ring

17. Working at the rear of the mainshaft, install the snap ring into the snap ring groove of the first (6th) speed gear and then, install the gear onto the shaft with clutch teeth facing rearward.

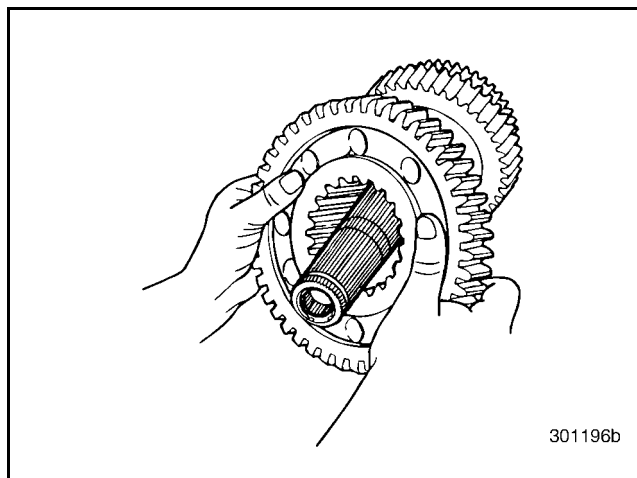

Figure 312 — Installing First Speed Gear

18. Install the external-toothed and internal-toothed thrust washers for the first (6th) speed gear onto the mainshaft.

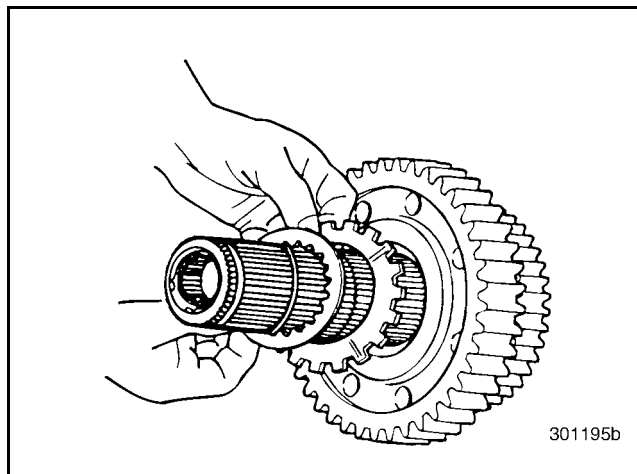

Figure 313 — Installing External- and Internal-Toothed Thrust Washers



REPAIR INSTRUCTIONS

19. Install the mainshaft snap ring for the first (6th) speed gear onto the shaft. Install into fourth groove from the front of the shaft.

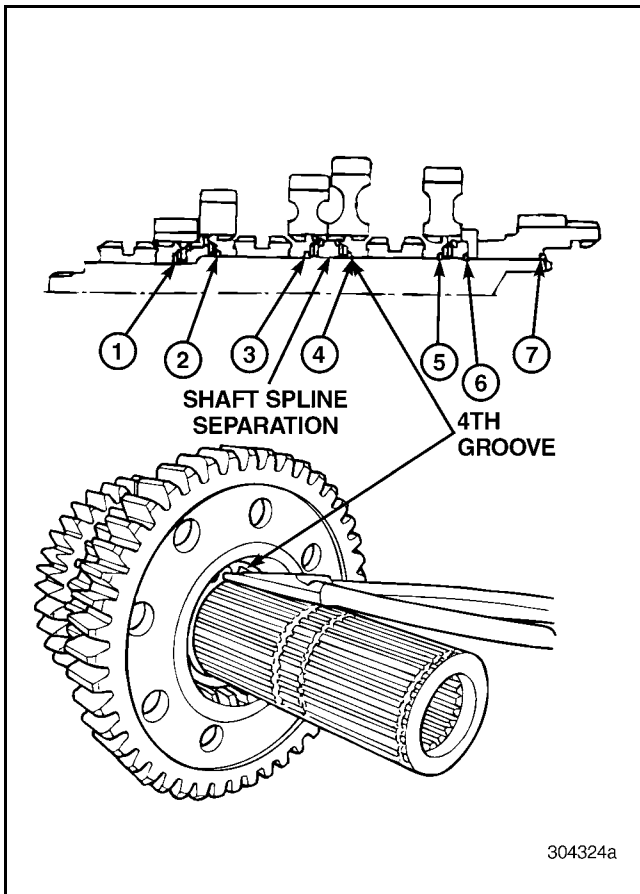

Figure 314 — Installing First Speed Gear Mainshaft Snap Ring

20. Install the first/reverse sliding clutch onto the mainshaft.

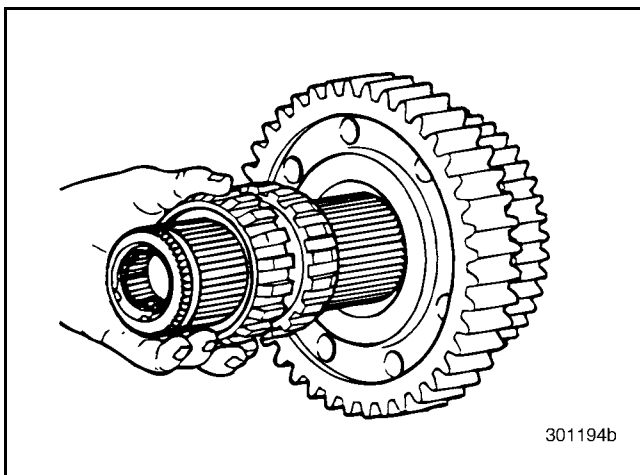

Figure 315 — Installing First/Reverse Sliding Clutch

21. Temporarily install the reverse speed gear onto the mainshaft over the first/reverse sliding clutch (clutch teeth face forward).

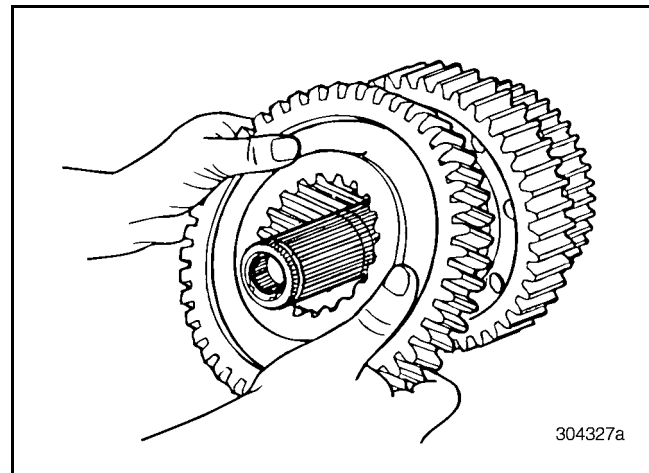

Figure 316 — Installing Reverse Speed Gear

22. Install the reverse speed gear mainshaft snap ring, using suitable snap ring pliers. Install into the fifth snap ring groove from the front (third from rear).

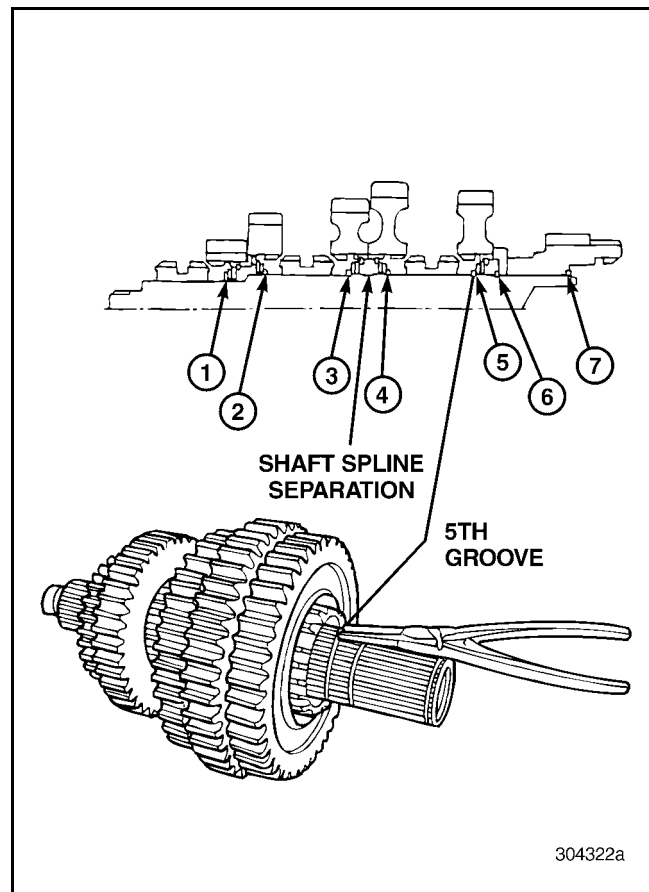

Figure 317 — Installing Reverse Gear Mainshaft Snap Ring



REPAIR INSTRUCTIONS

NOTE

The reverse speed gear thrust washers and remaining snap ring will be installed after the mainshaft has been installed into the case during transmission reassembly.

Main Drive Pinion Reassembly [322]

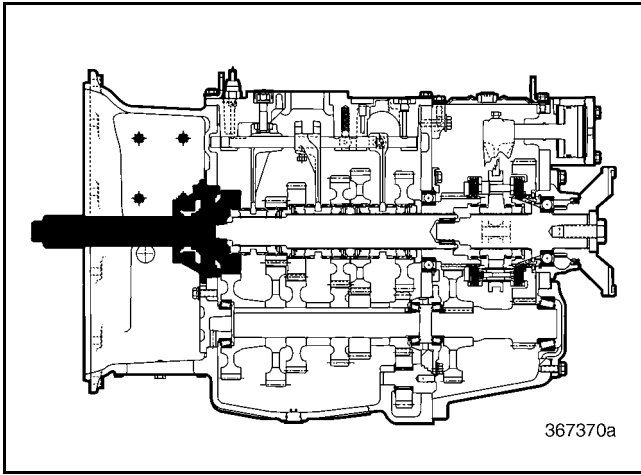

Figure 318 — Main Drive Pinion Component Locator

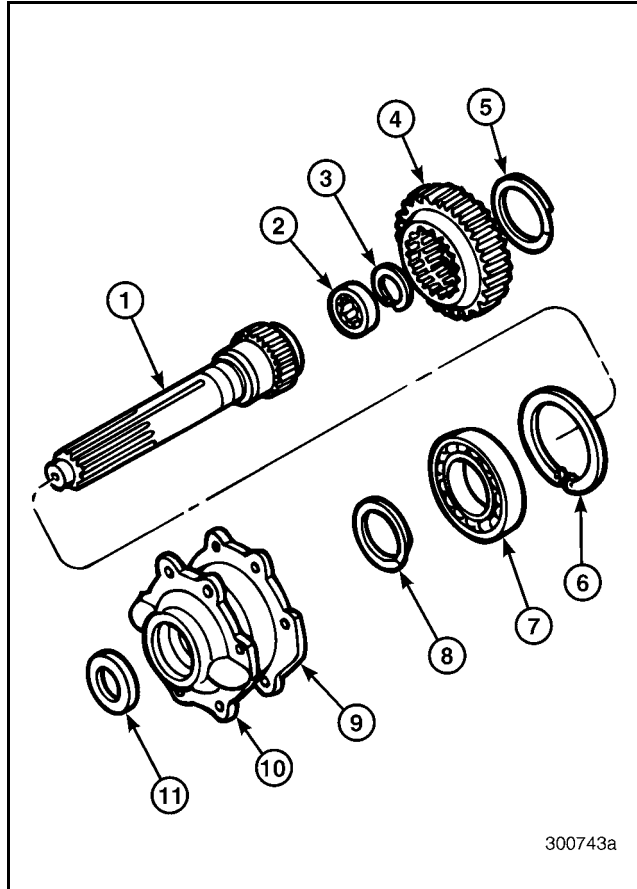

Figure 319 — Exploded View of Main Drive Pinion

- | | |
|----------------------------|--------------------------|
| 1. Main Drive Pinion Shaft | 7. Bearing |
| 2. Spigot Bearing | 8. Spiral Snap Ring |
| 3. Snap Ring | 9. Gasket |
| 4. Main Drive Pinion Gear | 10. Pinion Bearing Cover |
| 5. Spiral Snap Ring | 11. Oil Seal |
| 6. Snap Ring | |



REPAIR INSTRUCTIONS

1. Press the ball bearing onto the main drive pinion shaft. Support the inner race of the bearing while pressing.

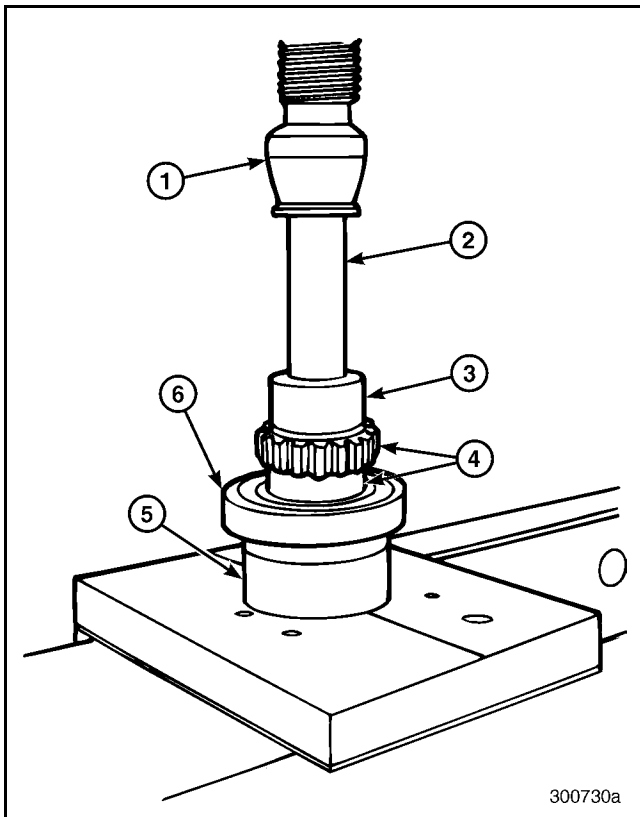

Figure 320 — Installing Main Drive Pinion Bearing

- | | |
|----------------|----------------------------|
| 1. Press | 4. Main Drive Pinion Shaft |
| 2. Spacer Tube | 5. Sleeve |
| 3. Driver | 6. Bearing |

2. To retain the ball bearing, install the spiral snap ring using a circular motion and, at the same time, pressing the snap ring tightly into the groove on the shaft.

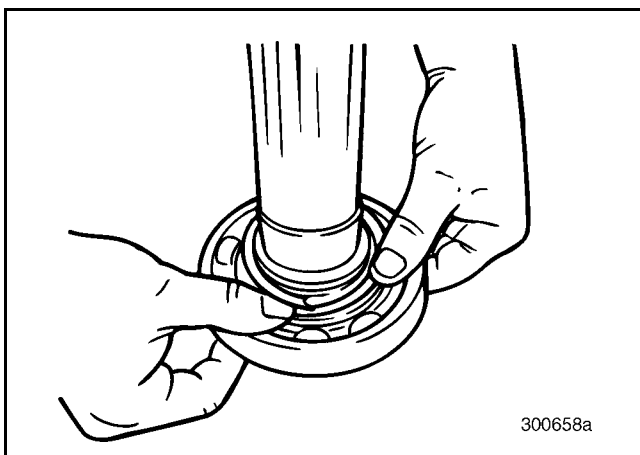

Figure 321 — Installing Spiral Snap Ring

3. Position a **new** oil seal in the main drive pinion bearing cover.

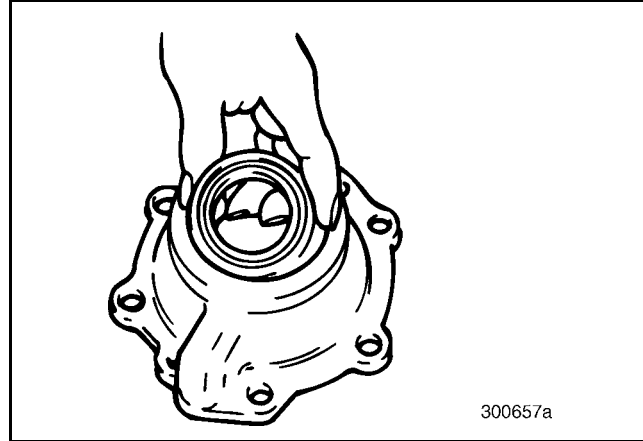

Figure 322 — Positioning Bearing Cover Oil Seal

4. Install the oil seal into the front of the main drive pinion bearing cover. Refer to "INSPECTION OF PARTS" on page 94 for tool use and installation instructions.

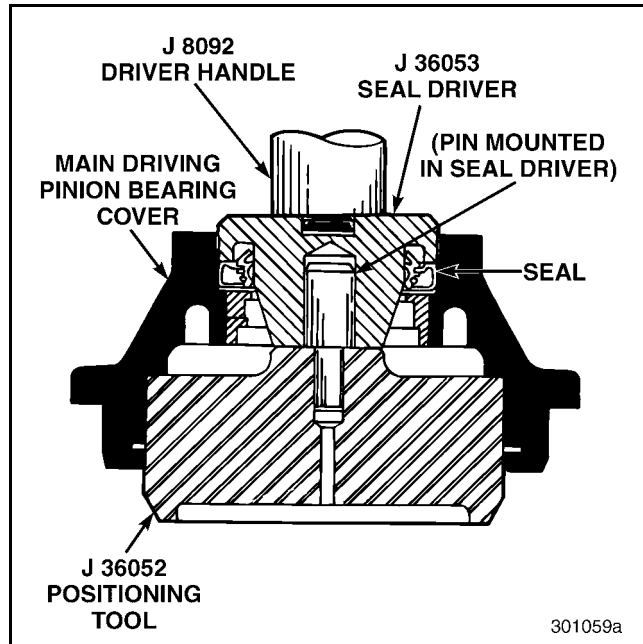

Figure 323 — Installing Bearing Cover Oil Seal



REPAIR INSTRUCTIONS

5. Press the main drive pinion shaft and bearing assembly into the main drive pinion bearing cover.

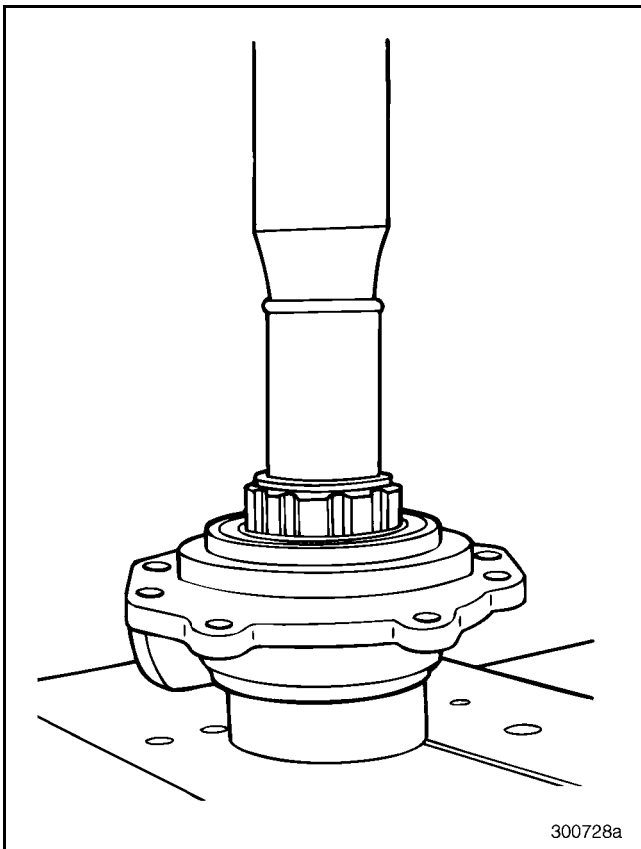

Figure 324 — Installing Main Drive Pinion Assembly into Drive Pinion Bearing Cover

6. Install the main drive pinion bearing snap ring, using suitable snap ring pliers.

WARNING

The large snap ring is very difficult to compress and may fly off the snap ring pliers, causing injury.

NOTE

One side of the large snap ring is bevelled and faces outward. The flat side of the snap ring is positioned against the bearing.

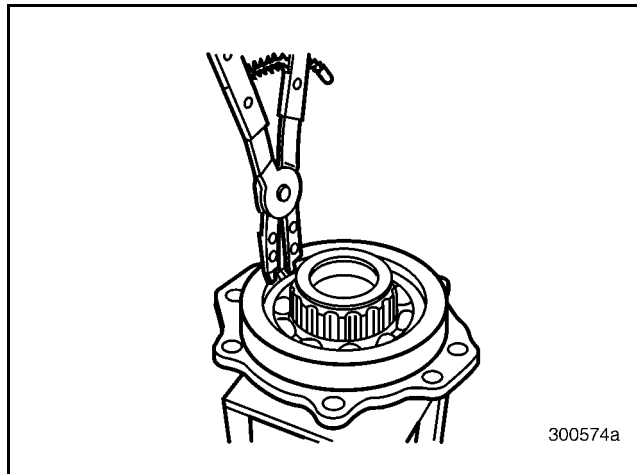

Figure 325 — Installing Snap Ring into Main Drive Pinion Bearing Cover

7. Install a **new** spigot bearing into the end of the main drive pinion shaft by hand, and then install the retaining snap ring.

NOTE

Drawn cup needle bearings (spigot bearings) have a specific direction that they must be installed. The radius end of the bearing is to be installed first. The flat end of the bearing faces out.

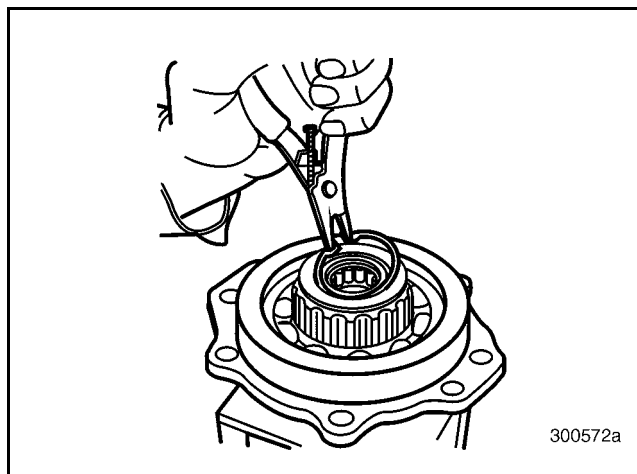

Figure 326 — Installing Spigot Bearing and Snap Ring



REPAIR INSTRUCTIONS

- Install the main drive pinion gear onto the pinion shaft. Install the spiral snap ring using a circular motion and, at the same time, pressing the snap ring tightly into the groove on the shaft.

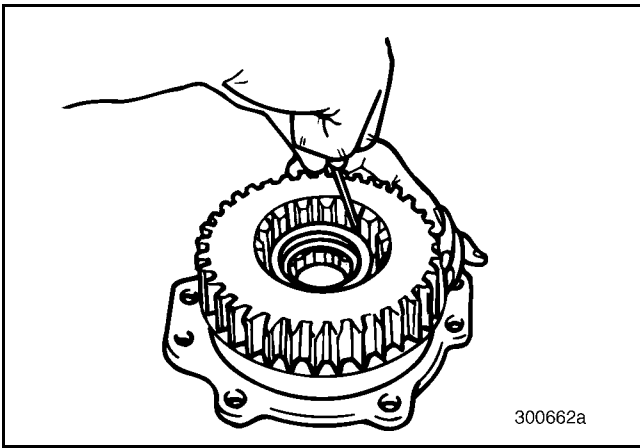

Figure 327 — Installing Main Drive Pinion Gear and Spiral Snap Ring

- Install a **new** bearing cover gasket, using sealant between the gasket and cover. Make sure the oil passage hole and capscrew holes in the gasket align with the cover holes.

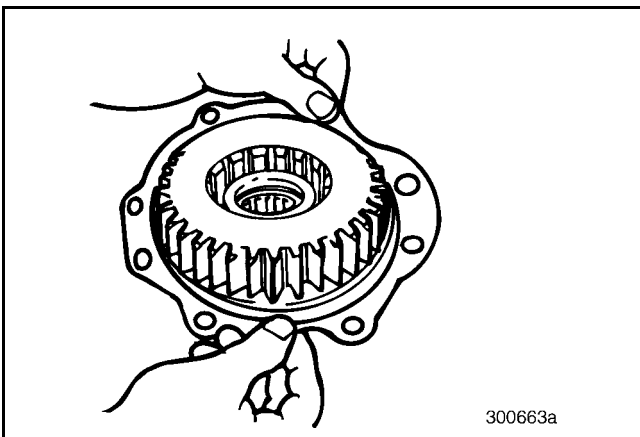

Figure 328 — Installing Main Drive Pinion Bearing Cover Gasket

Range Shift Valve [323]

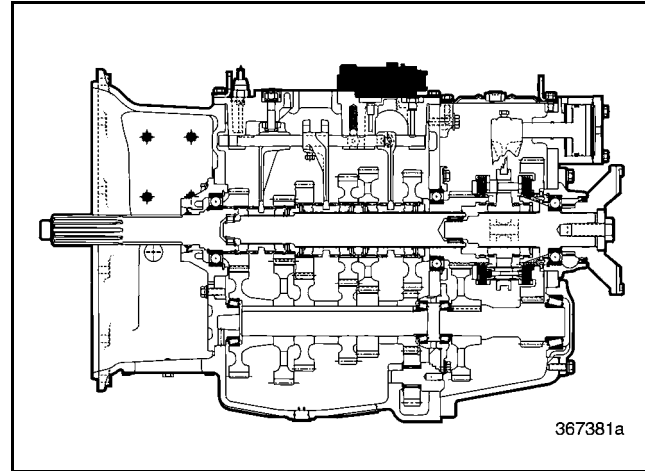

Figure 329 — Range Shift Valve Component Locator

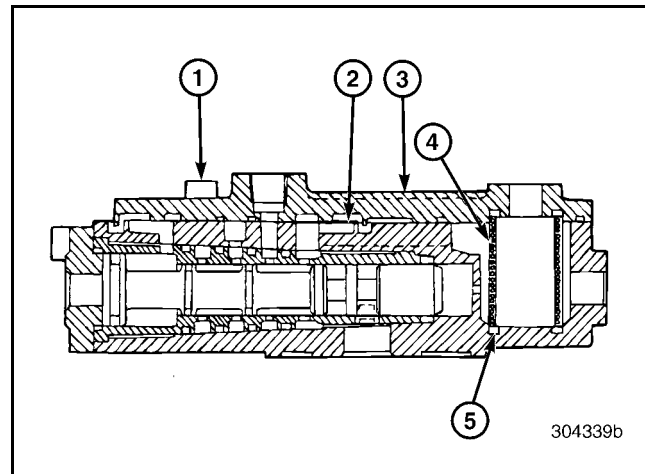

Figure 330 — Cutaway View of Range Shift Valve Assembly

- | | |
|-------------------|---------------------------|
| 1. 4 mm Screw | 4. Sintered Bronze Filter |
| 2. Top Cover Seal | 5. Silicon Rubber O-Ring |
| 3. Top Cover | |



REPAIR INSTRUCTIONS

1. Install the filter O-ring and bronze filter into the filter bore of the housing. Set the filter on top of the O-ring.

NOTE

Lightly lubricate the O-ring before installation. Over lubricating the O-ring may restrict the filter. Make sure to properly seat the O-ring.

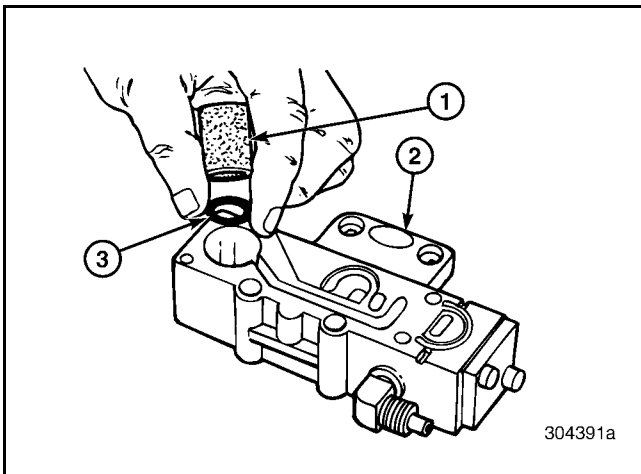

Figure 331 — Installing O-Ring and Filter

- | | |
|---------------------------|------------------|
| 1. Sintered Bronze Filter | 3. Filter O-Ring |
| 2. Valve Housing | |

2. Position a **new** top cover seal (if required) into the groove of the top cover. Lightly lubricate the seal before installation, and make sure all portions of the seal are properly located.

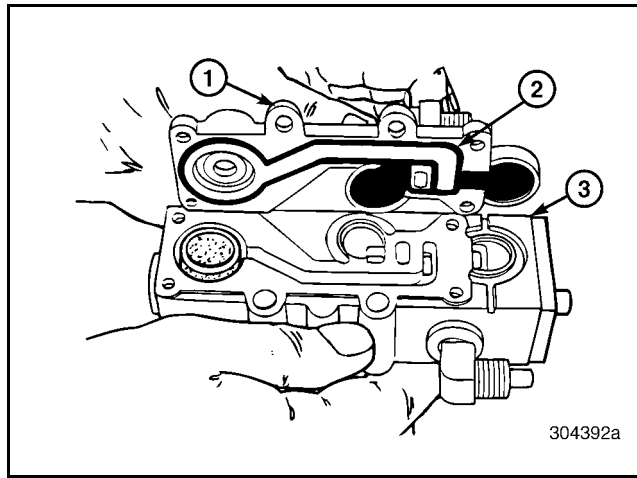

Figure 332 — Installing Top Cover Seal

- | | |
|----------------------|------------------|
| 1. Housing Top Cover | 3. Valve Housing |
| 2. Top Cover Seal | |

3. Install the top cover over the range shift valve body. Install the cover screws and tighten the screws to the specified torque.

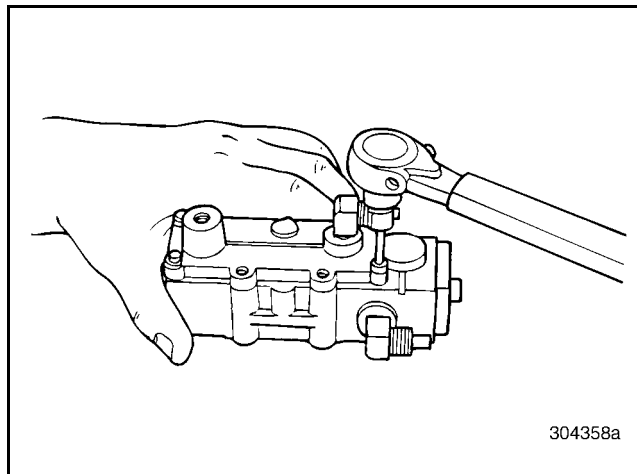

Figure 333 — Installing Top Cover

4. Set the assembly aside for later installation onto the main case shift cover.



REPAIR INSTRUCTIONS

Two-Position Range Shift Cylinder Reassembly [324]

NOTE

Installing the Teflon® seal into the shift rail bores requires a special insertion tool to expand the seal into the groove. This tool must be locally fabricated from a length of nylon or plastic stock, 7-5/8 inches (19.4 mm) long and 1-1/8 inches (2.9 mm) in diameter. Refer to Figure 336 for a machining illustration and dimensions.

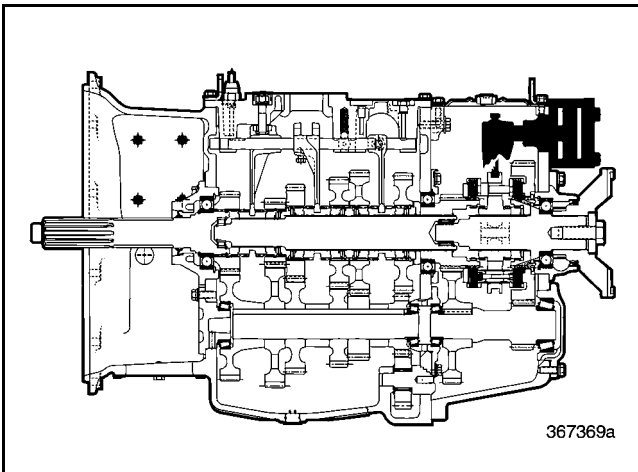

Figure 334 — Range Shift Cylinder Component Locator

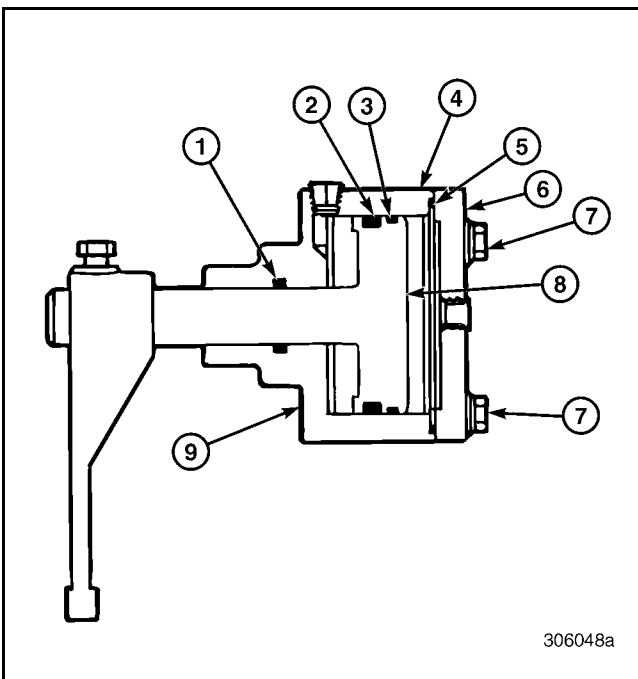

Figure 335 — Cutaway View of Two-Position Range Shift Cylinder

1. Shift Rail Seal	6. Cylinder Housing Cover
2. Piston Seal	7. Bolt
3. Shift Cylinder Wiper Ring	8. Piston/Shift Rail Assembly
4. Shift Cylinder Housing	9. Gasket
5. Housing-to-Cover O-Ring	



REPAIR INSTRUCTIONS

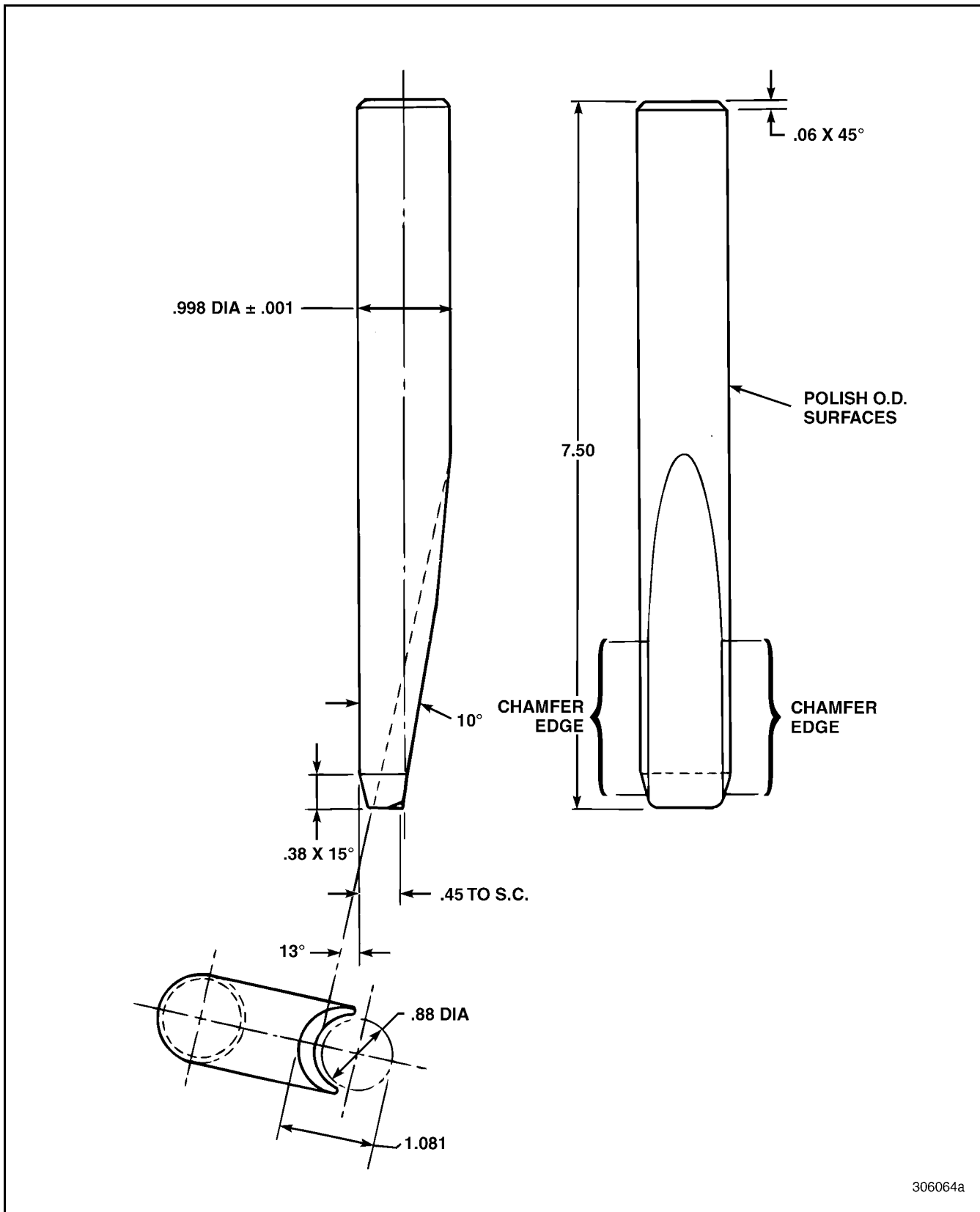

Figure 336 — Shift Rail Teflon® Seal Insertion Tool



REPAIR INSTRUCTIONS

1. Install a **new** O-ring into the groove in the shift rail bore.
2. Form the Teflon® seal into a kidney shape as shown in Figure 337.

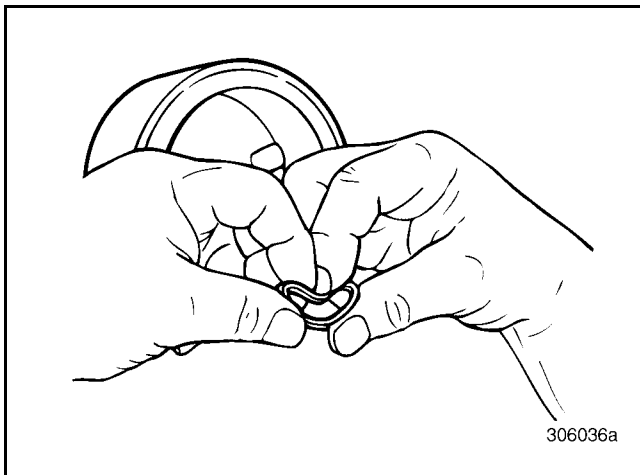

Figure 337 — Forming Seal

3. Insert the Teflon® seal into the cylinder bore and gently work the seal inside the bore and around the O-ring so that the seal lips seat over each side of the O-ring.

NOTE

Note that the back side of the Teflon® seal is contoured to the shape of the O-ring. It is important that the contour of the seal fits the O-ring and that the seal lips are not bent over. Failure to properly fit the seal around the O-ring results in damage to the seal during the next step of the installation process.

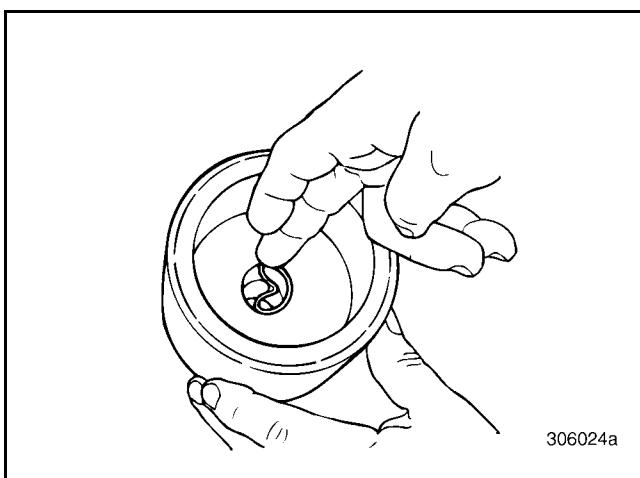

Figure 338 — Inserting Teflon® Seal into Shift Rail Bore

4. Align the relief of the insertion tool with the “V” fold of the seal. Gently insert the tool into the bore and push the tool all the way into the bore until the relief at the end of the tool is fully visible as shown in Figure 339 and Figure 340.

NOTE

Use care to avoid damaging the seal. For best results, gently twist the tool while it is being inserted. This aids in reforming the “V” fold of the Teflon® seal to the circumference of the shift rail bore.

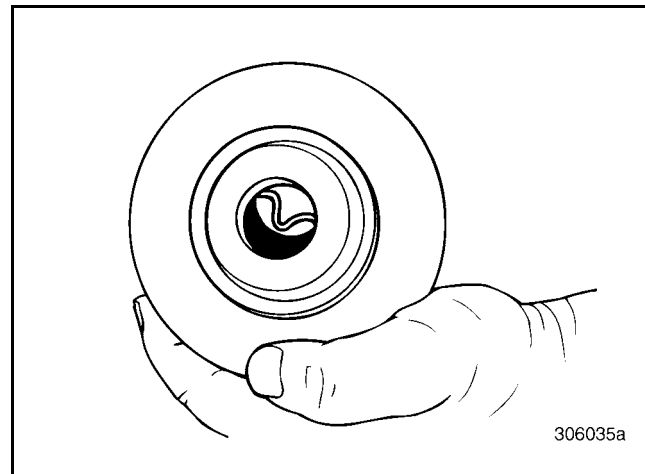

Figure 339 — Inserting Seal Insertion Tool

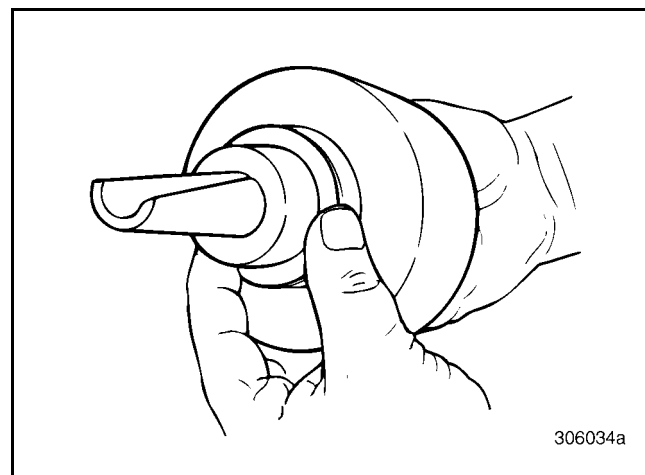

Figure 340 — Insertion Tool Fully Inserted



REPAIR INSTRUCTIONS

SERVICE HINT

After the tool has been fully inserted, leave the tool in place while the remaining cylinder rebuild procedures are performed. This allows the Teflon® seal to form to the circumference of the shift rail bore.

5. On the shift piston, install a **new** O-ring into the second groove of the piston.

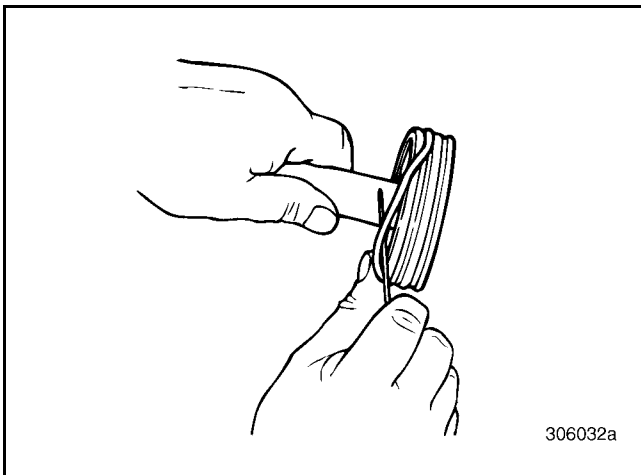

Figure 341 — Installing O-Ring into Second Groove of Piston

6. Carefully install the Teflon® seal over the O-ring in the second groove of the piston.

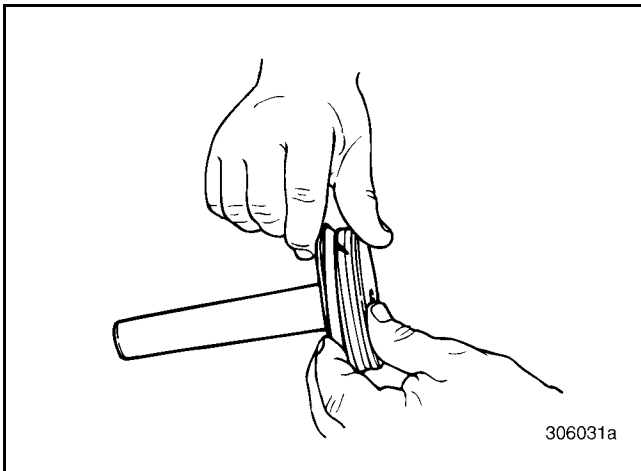

Figure 342 — Installing Teflon® Seal

CAUTION

Do not over-stretch the Teflon® seal. Be sure that the seal lips seat over each side of the O-ring.

7. Using a small engine ring compressor or other suitable type of ring compressor, compress the Teflon® seal to facilitate installation into the cylinder housing.

NOTE

If a small engine ring compressor or other suitable type of ring compressor is not available, a shielded hose clamp may be used. Use of any hose clamp other than a shielded hose clamp results in damage to the Teflon® seal.

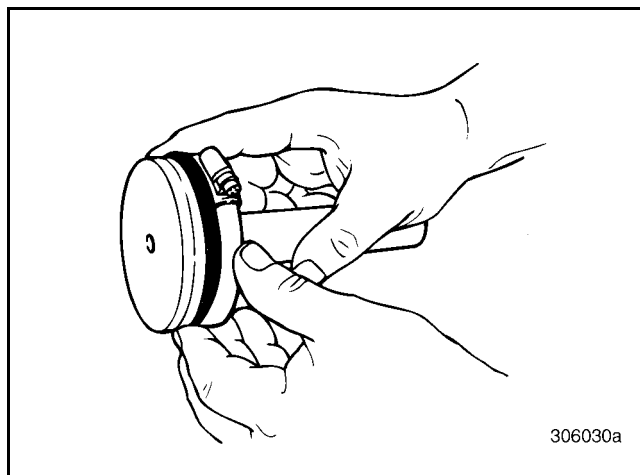

Figure 343 — Installing a Shielded Hose Clamp to Compress the Teflon® Seal

8. After installing the ring compressor, tighten sufficiently so that the piston can be installed into the assembly.

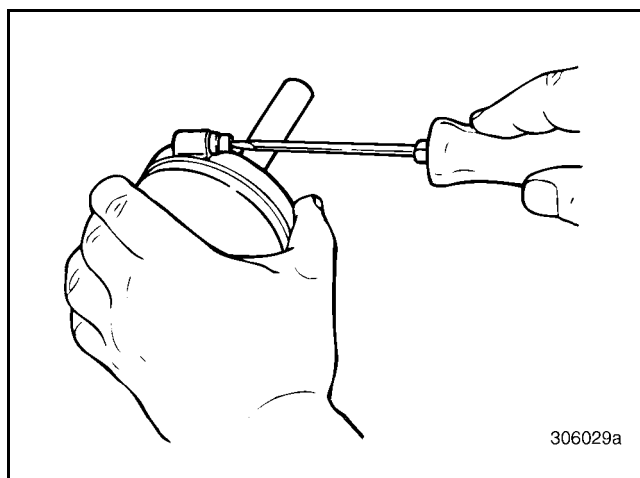

Figure 344 — Tighten Ring Compressor (Shielded Hose Clamp Shown)



REPAIR INSTRUCTIONS

NOTE

It is recommended that the piston assembly be allowed to sit for 15 minutes with the ring compressor (or shielded hose clamp) installed before proceeding with the next step. This will size the seal to the piston.

9. With the cylinder housing properly secured in a vise, install the piston assembly. Be sure to install the piston with the shift fork locking bolt hole in the rail facing the air line port in the cylinder housing as shown in Figure 345.

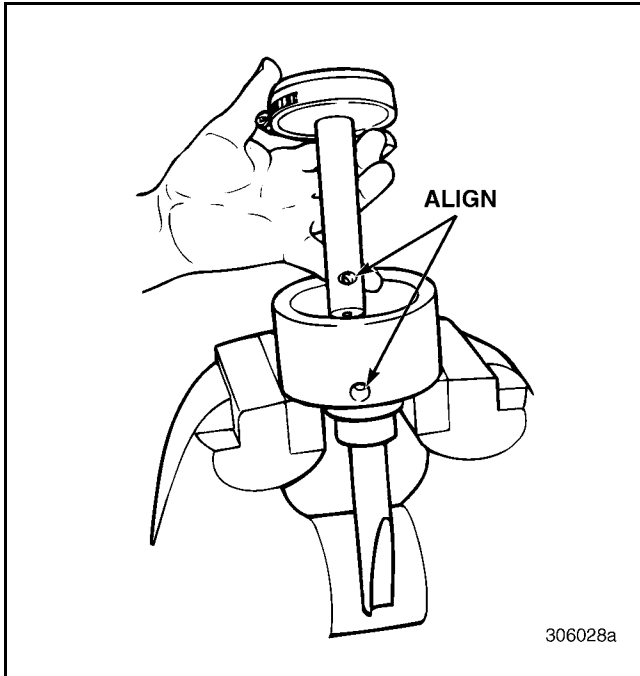

Figure 345 — Installing Piston Assembly

10. As the piston/shift rail is installed, the installation tool is pushed from the cylinder bore. Do not remove the installation tool prior to installing the piston/shift rail assembly.
11. Install the piston until the ring compressor rests on the edge of the cylinder housing and then, push the piston into the cylinder far enough so that the Teflon® seal just enters the bore. The first ring groove on the piston must remain above the cylinder housing so that the wiper ring can be installed.

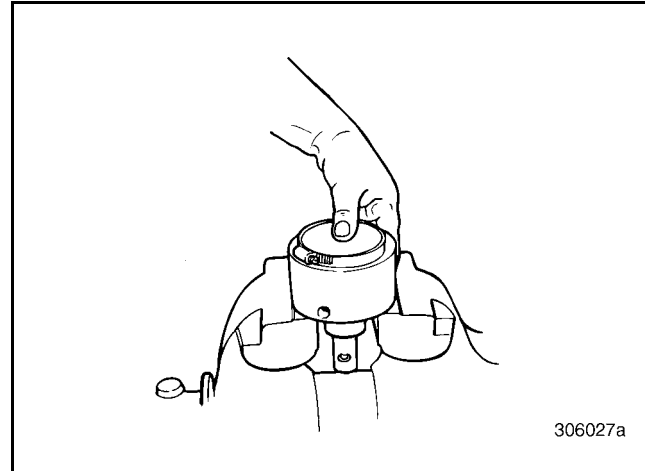

Figure 346 — Piston Assembly Installed in Cylinder Housing Bore

12. Remove the ring compressor or shielded clamp from the second ring area.
13. Install the wiper ring in the first piston ring groove.

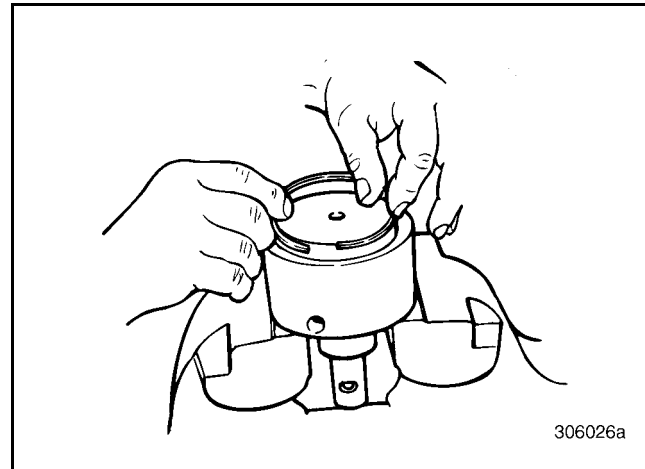

Figure 347 — Installing Wiper Ring

14. After installing the wiper ring, compress the wiper with fingers and gently tap the piston into the cylinder housing until the piston is fully inside the housing bore.



REPAIR INSTRUCTIONS

Main Case Shift Cover Reassembly [323]

1. Install the shift cover breather vent into the cover.

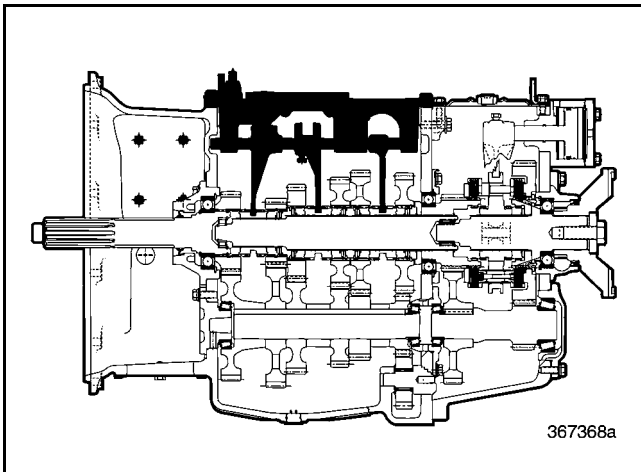

Figure 348 — Main Case Shift Cover Component Locator

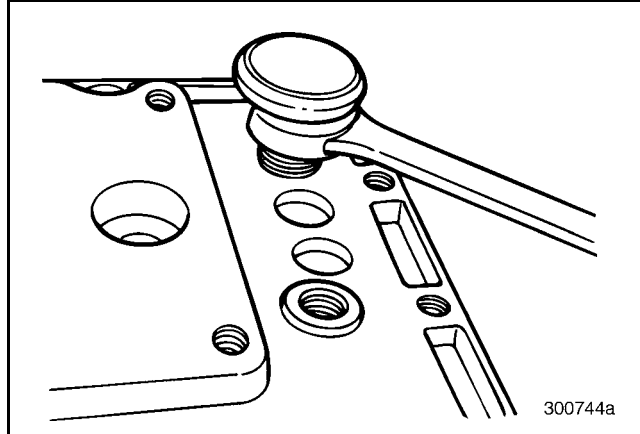
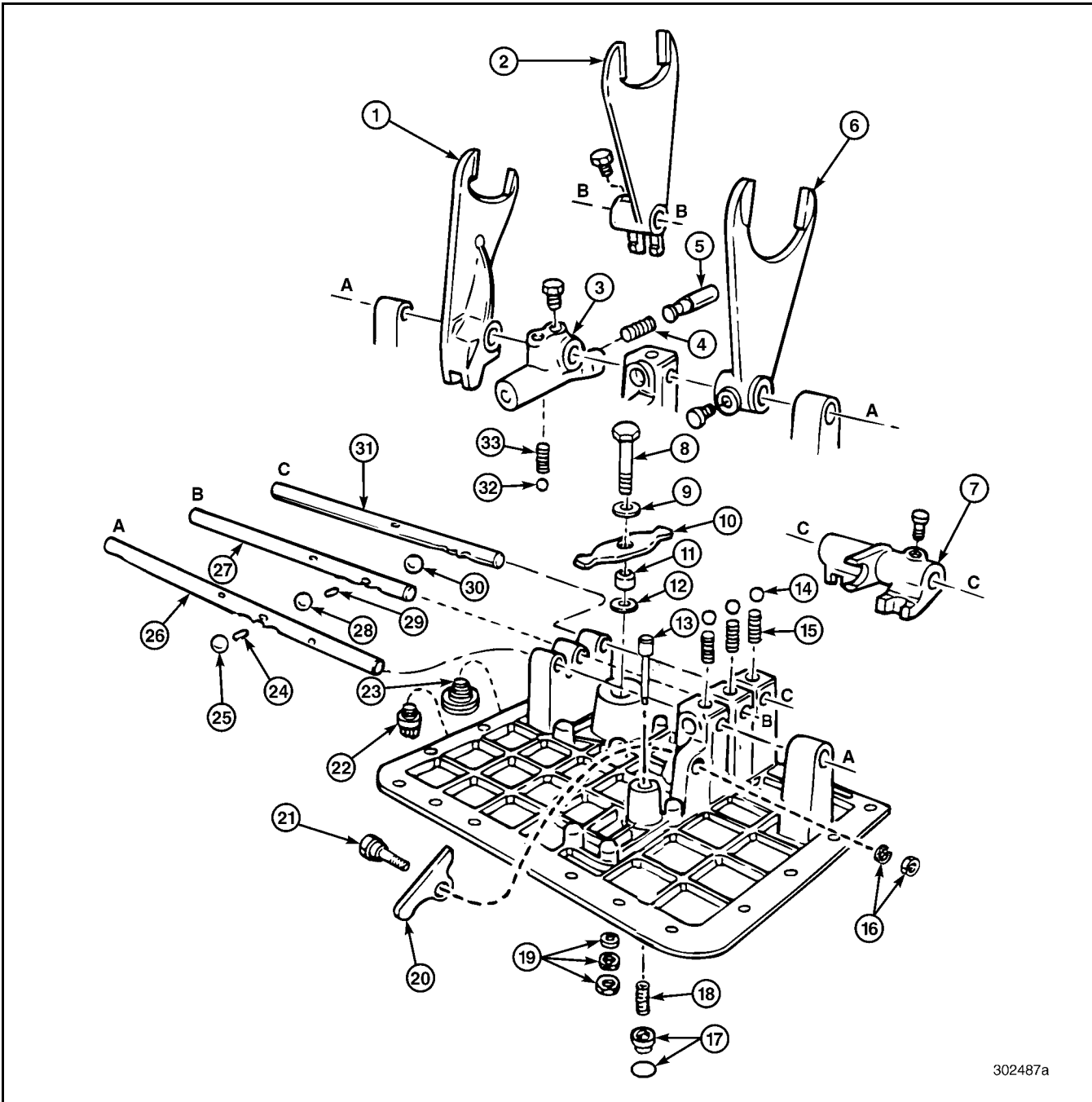

Figure 349 — Installing Breather Vent



REPAIR INSTRUCTIONS



302487a

Figure 350 — Exploded View of Main Case Shift Cover

1. 4th/5th Shift Fork	12. Washer	23. Breather
2. 2nd/3rd Shift Fork	13. Interlock Pin	24. Interlock Pin
3. 1st/Reverse Shifter	14. Poppet Ball	25. Interlock Ball
4. Shifter Body Spring (Interlock)	15. Poppet Ball Spring	26. 1st/Reverse Shift Rail
5. Shifter Body Plunger (Interlock)	16. Interlock Rocker Hardware	27. 2nd/3rd Shift Rail
6. 1st/Reverse Shift Fork	17. Interlock Sleeve and O-Ring	28. Interlock Ball
7. 4th/5th Shifter	18. Interlock Spring	29. Interlock Pin
8. 4th/5th Rocker Pin	19. 4th/5th Rocker Pin Hardware	30. Interlock Ball
9. Washer	20. Interlock Rocker	31. 4th/5th Shift Rail
10. 4th/5th Rocker Arm	21. Interlock Rocker Bolt	32. 1st/Reverse Shifter Ball
11. Bushing	22. Pipe Plug	33. 1st/Reverse Shifter Spring



REPAIR INSTRUCTIONS

2. Install the fourth/fifth rocker pin and rocker arm. Be sure to position the washer, bushing and washer on the rocker pin as illustrated. The bottom washer is positioned between the rocker arm and main case shift cover.

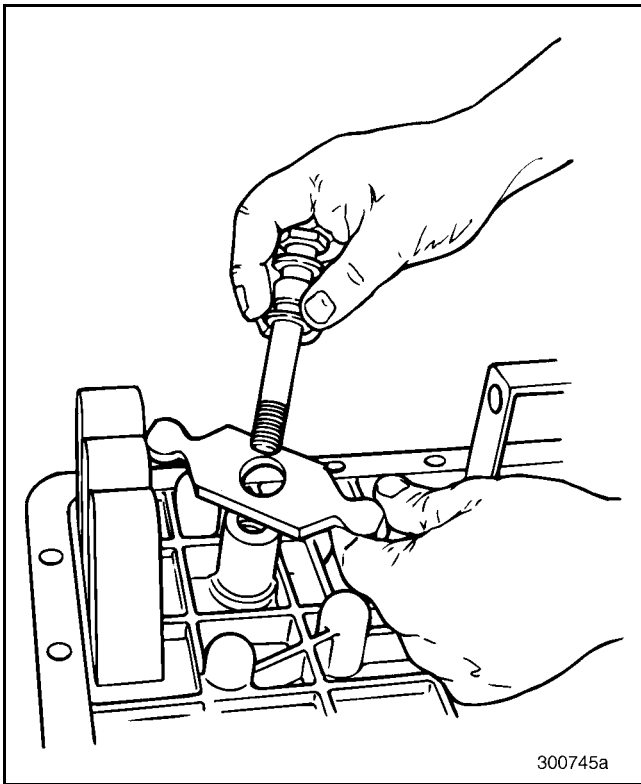

Figure 351 — Installing Fourth/Fifth Rocker Pin and Rocker Arm

3. Install the fourth/fifth pin lock washer, flat washer and nut. Tighten nut to the specified torque.

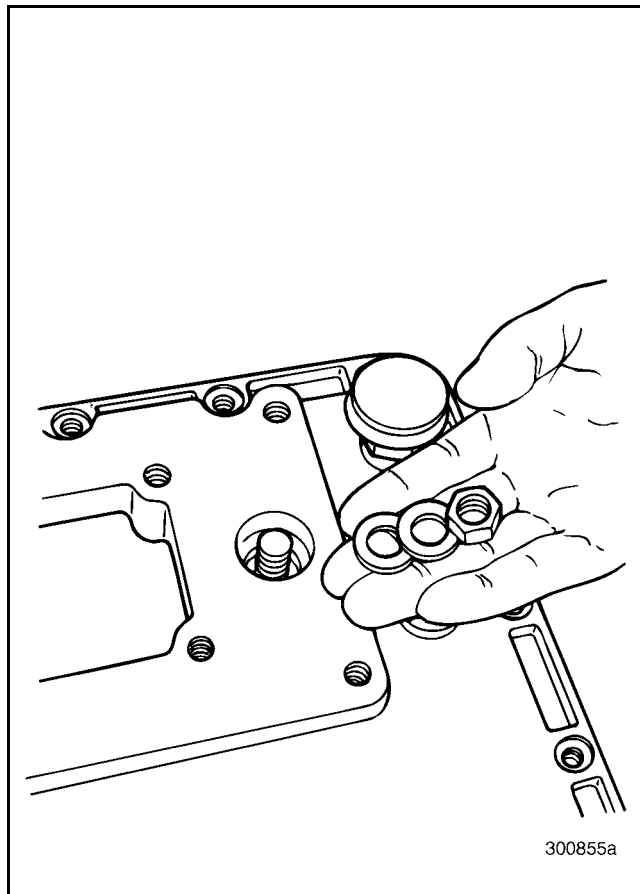

Figure 352 — Installing Washers and Nut

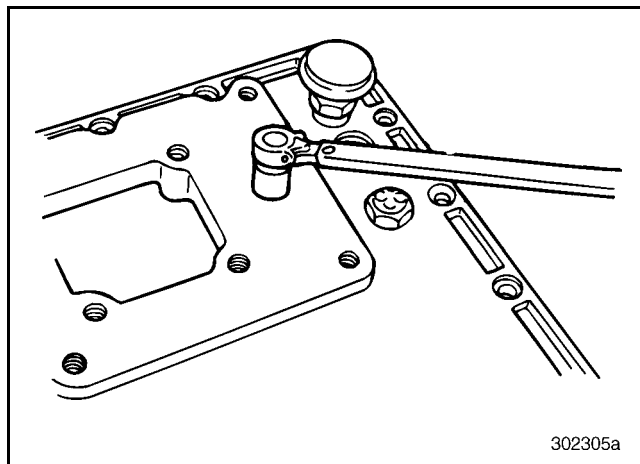

Figure 353 — Tightening Nut



REPAIR INSTRUCTIONS

4. Install the reverse light switch rod into the shift cover.

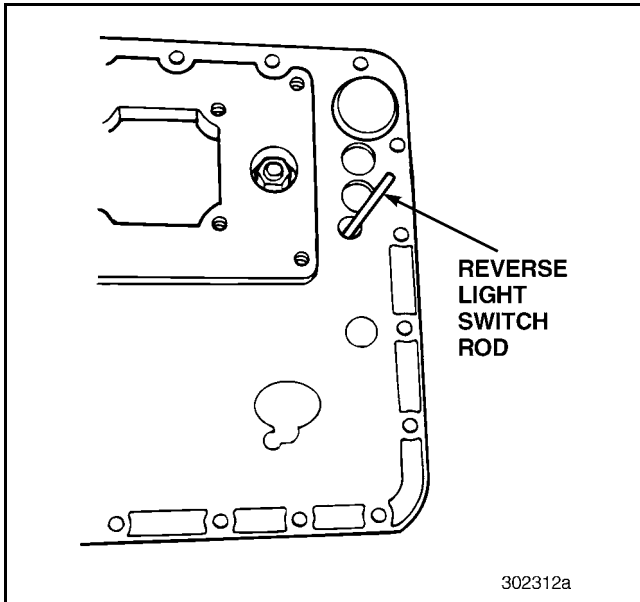

Figure 354 — Installing Reverse Light Switch Rod

5. Install the reverse light switch into the shift cover.

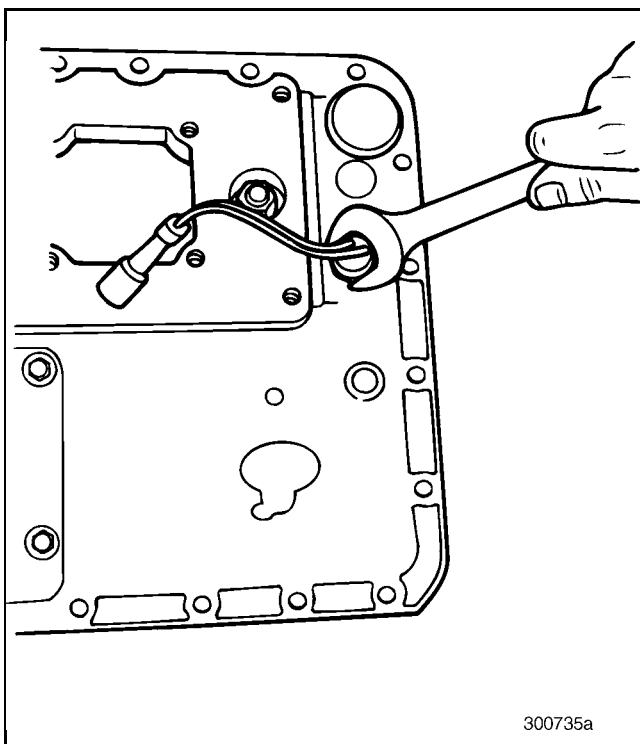

Figure 355 — Installing Reverse Light Switch

6. Install the poppet ball and spring for the fourth/fifth shift rail.

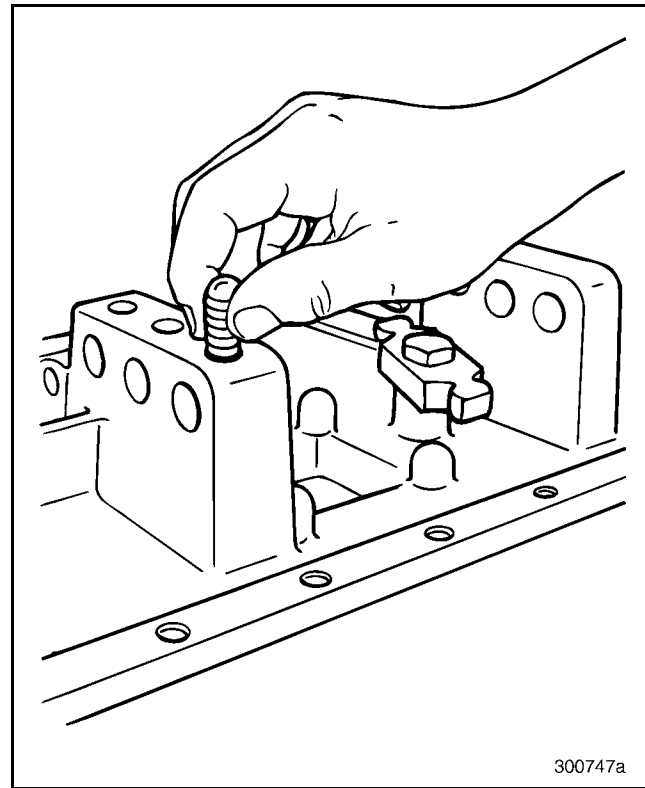

Figure 356 — Installing Poppet Ball and Spring

7. Slide the fourth/fifth shift rail into the cover. At the same time, install the fourth/fifth shifter onto the shift rail.

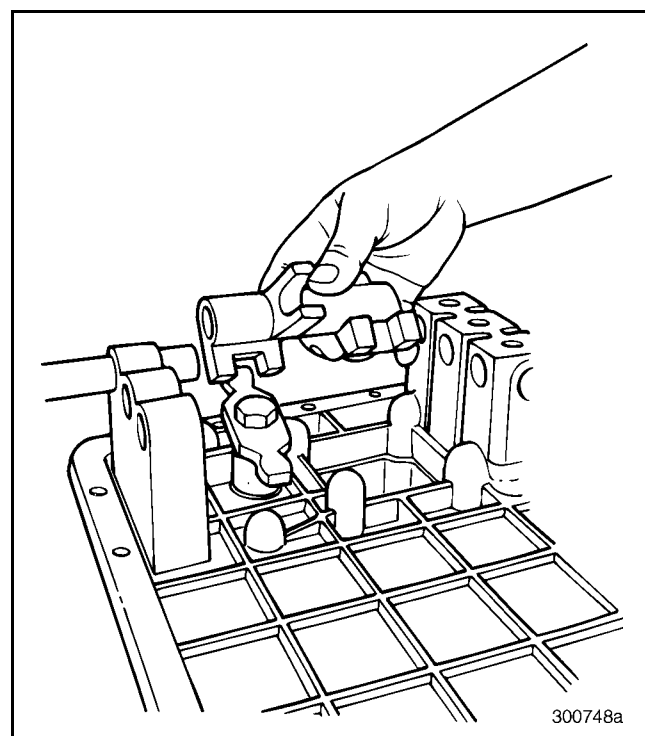

Figure 357 — Installing Shift Rail and Shifter



REPAIR INSTRUCTIONS

8. Press the poppet ball down while sliding the fourth/fifth shift rail over the ball. A hollow tube works well to press down the ball.

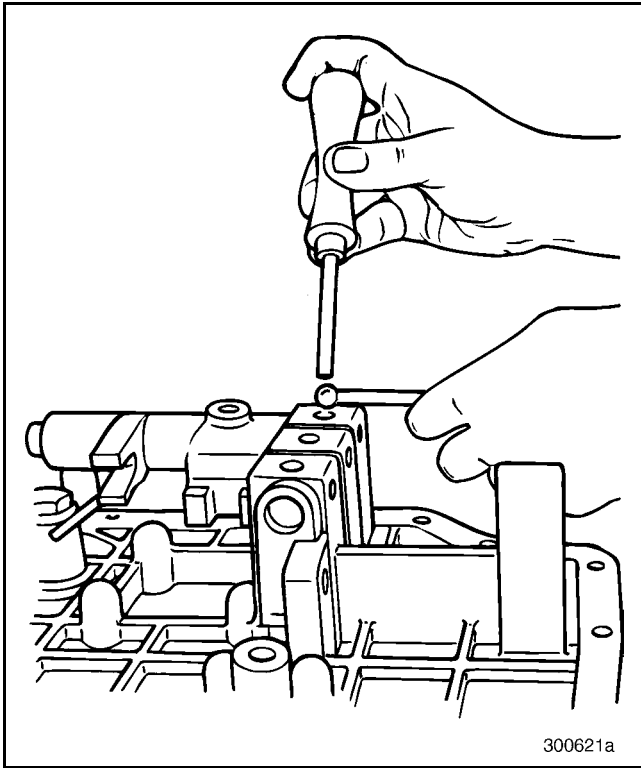

Figure 358 — Pushing Poppet Ball Down

9. Align the setscrew in the fourth/fifth shifter with the notch in the shift rail. Tighten the setscrew to the specified torque.

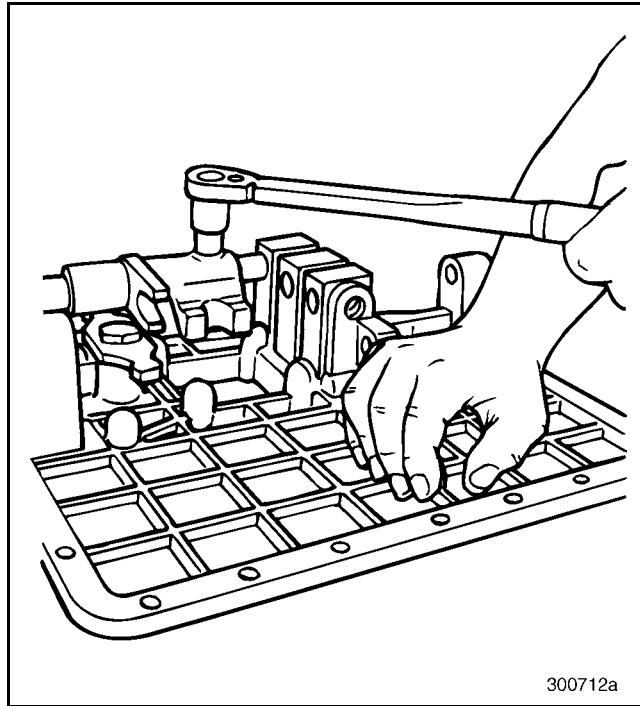

Figure 359 — Tightening Setscrew

10. Slide the second/third shift rail into the shift cover. At the same time, install the second/third shift fork onto the shift rail.

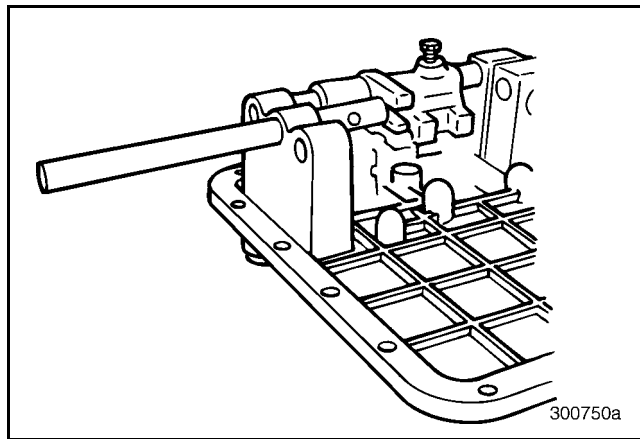

Figure 360 — Installing Second/Third Shift Rail



REPAIR INSTRUCTIONS

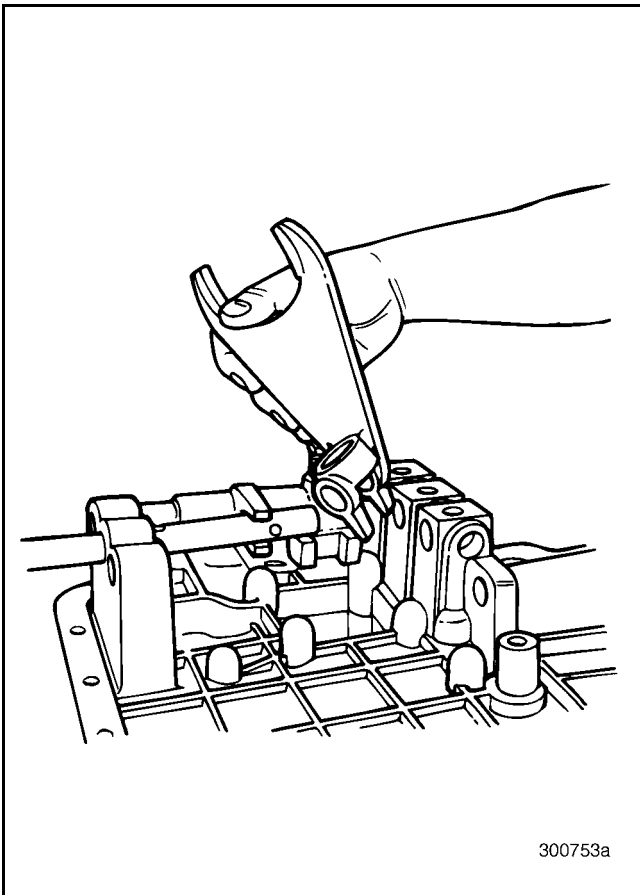

Figure 361 — Installing Second/Third Shift Fork

11. Install the interlock pin into the second/third shift rail.

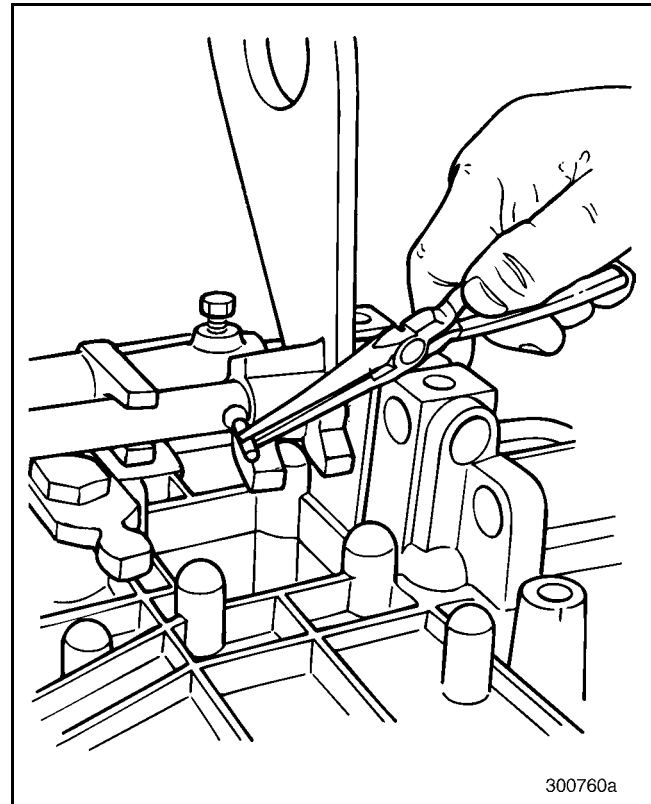

Figure 362 — Installing Pin into Second/Third Shift Rail



REPAIR INSTRUCTIONS

12. Install the interlock ball between the second/third shift rail and the fourth/fifth shift rail.

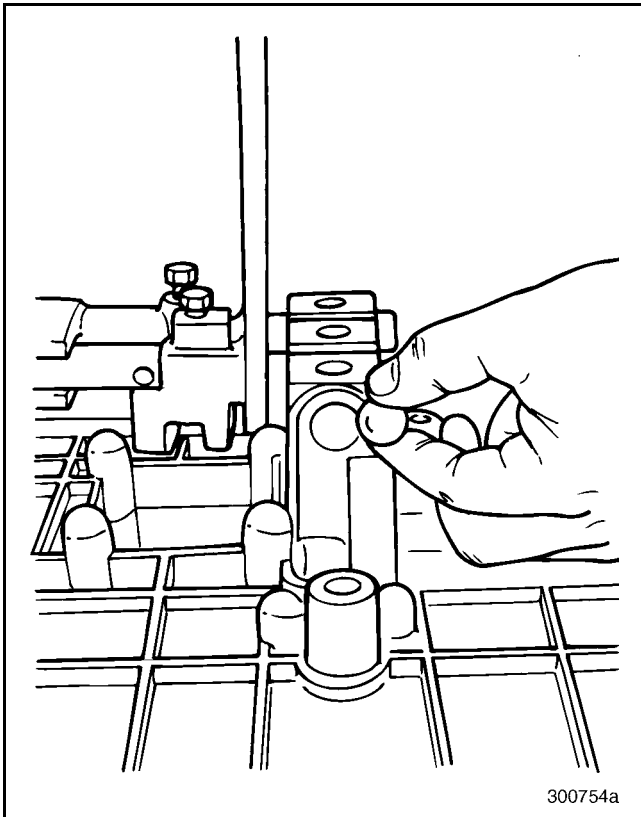

Figure 363 — Installing Interlock Ball Between Rails

13. Install the poppet ball and spring for the second/third shift rail.

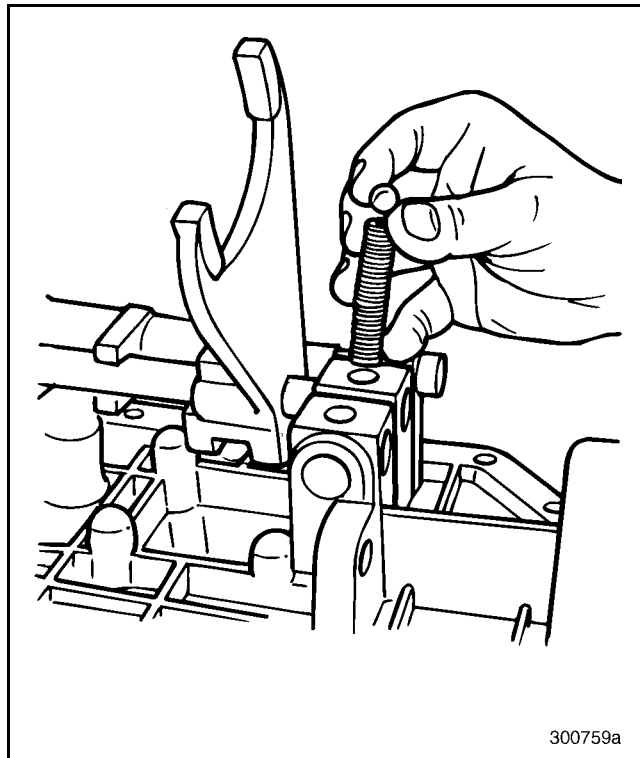

Figure 364 — Installing Poppet Ball and Spring

14. Press the poppet ball down while sliding the second/third shift rail over the ball. A hollow tube works well to press down the ball.

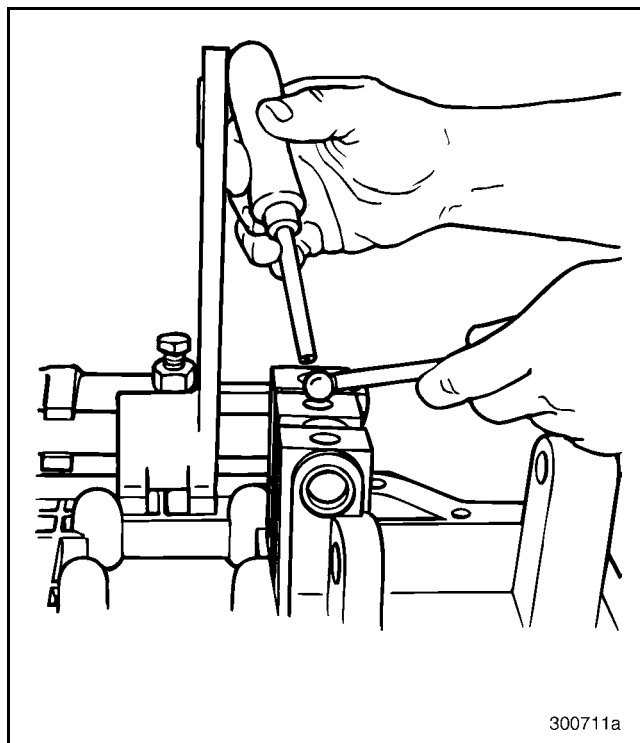

Figure 365 — Pressing Poppet Ball Down



REPAIR INSTRUCTIONS

15. Align the setscrew in the second/third shift fork with the notch in the shift rail. Tighten the setscrew to the specified torque.

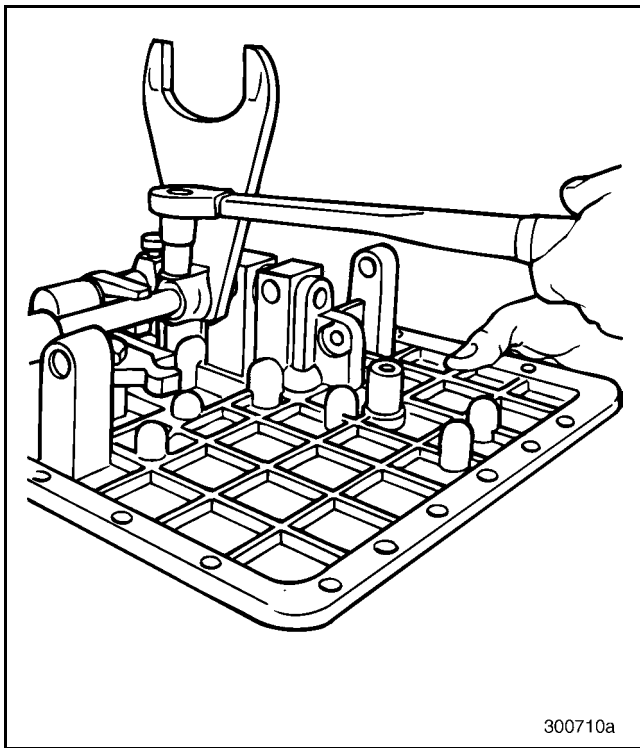

Figure 366 — Tightening Setscrew

16. Slide the first/reverse shift rail into the shift cover. At the same time, install the fourth/fifth shift fork onto the shift rail.

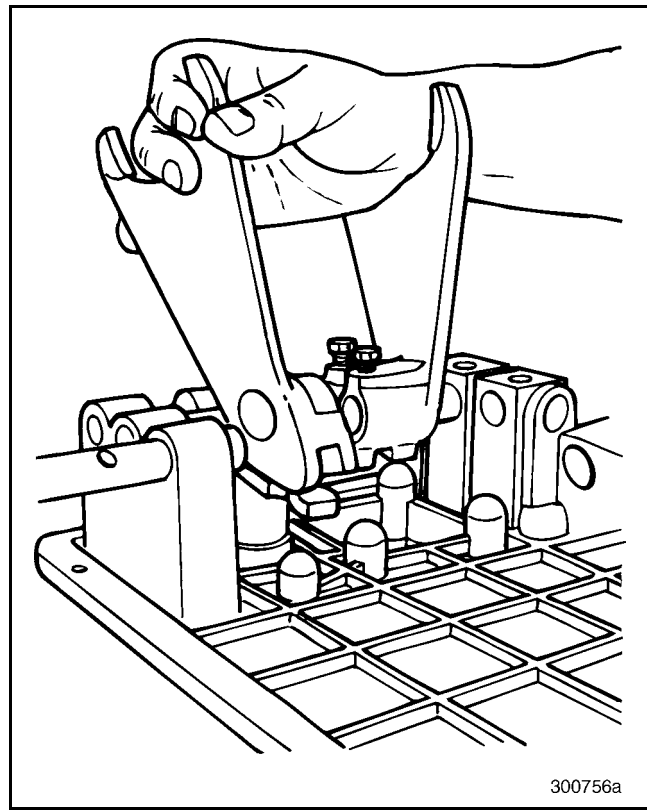

Figure 367 — Installing Fourth/Fifth Shift Fork

17. Install the poppet ball and spring into the first/reverse shifter, followed by the spring and plunger. Depress the poppet ball and spring into the shifter to allow the spring and plunger to pass. The poppet ball rests in the radius of the plunger.

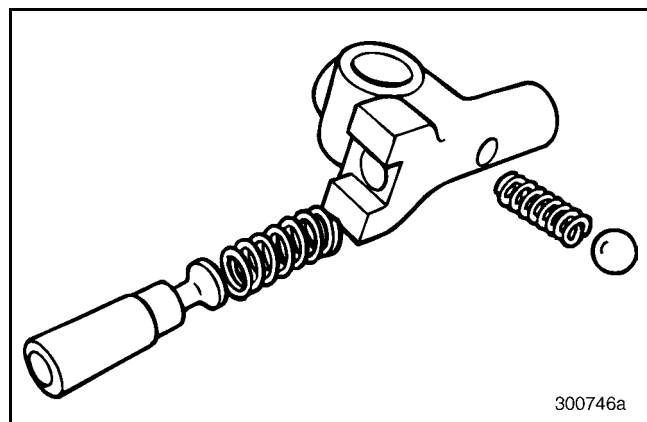

Figure 368 — Assembling First/Reverse Shifter



REPAIR INSTRUCTIONS

18. Install the first/reverse shifter onto the shift rail, behind the fourth/fifth shift fork.

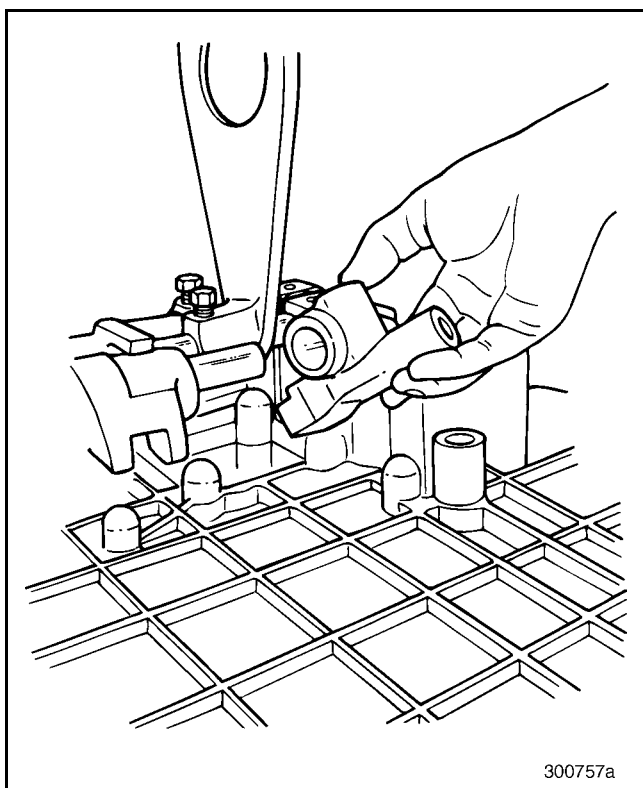

Figure 369 — Installing First/Reverse Shifter

19. Install the interlock ball between the first/reverse shift rail and the second/third shift rail.

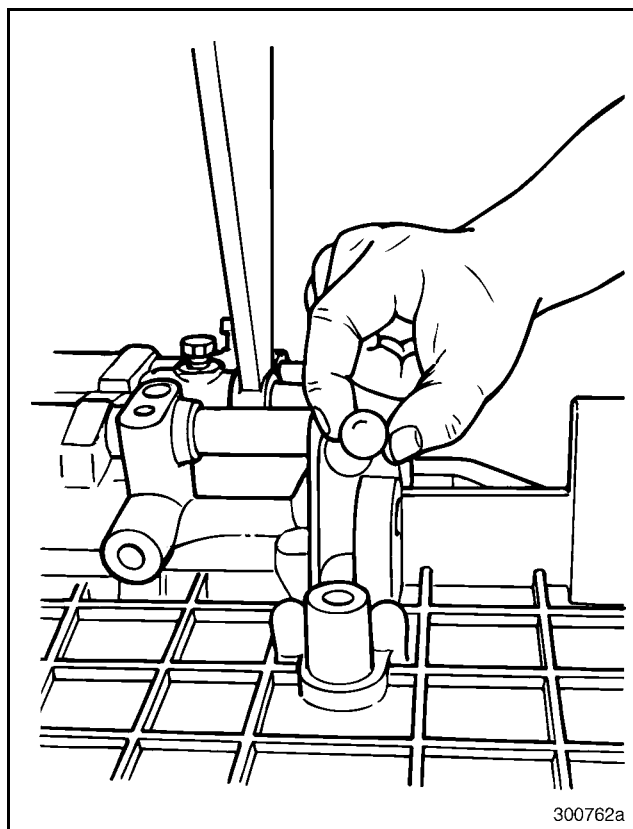

Figure 370 — Installing Interlock Ball



REPAIR INSTRUCTIONS

20. Install the poppet ball and spring for the first/reverse shift rail.

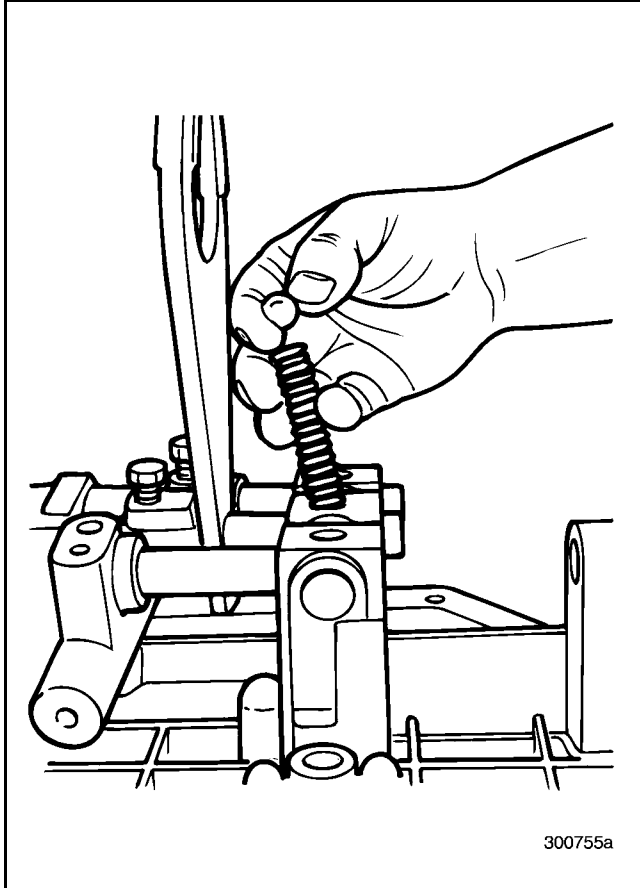

Figure 371 — Installing Poppet Ball and Spring

21. Press the poppet ball down while sliding the first/reverse shift rail over the ball. A hollow tube works well to press down the ball.

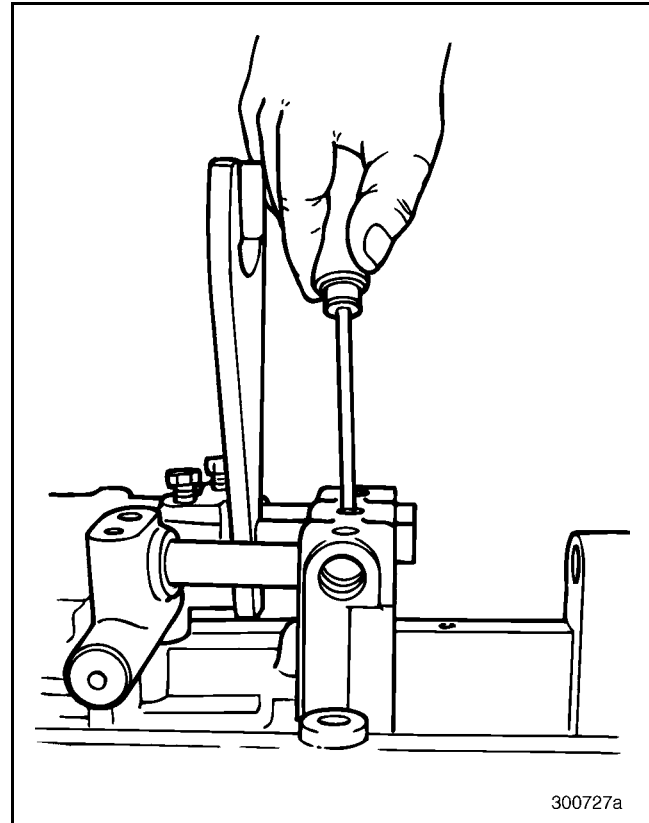

Figure 372 — Pushing Poppet Ball Down



REPAIR INSTRUCTIONS

22. Install the first/reverse shift fork onto the first/reverse shift rail.

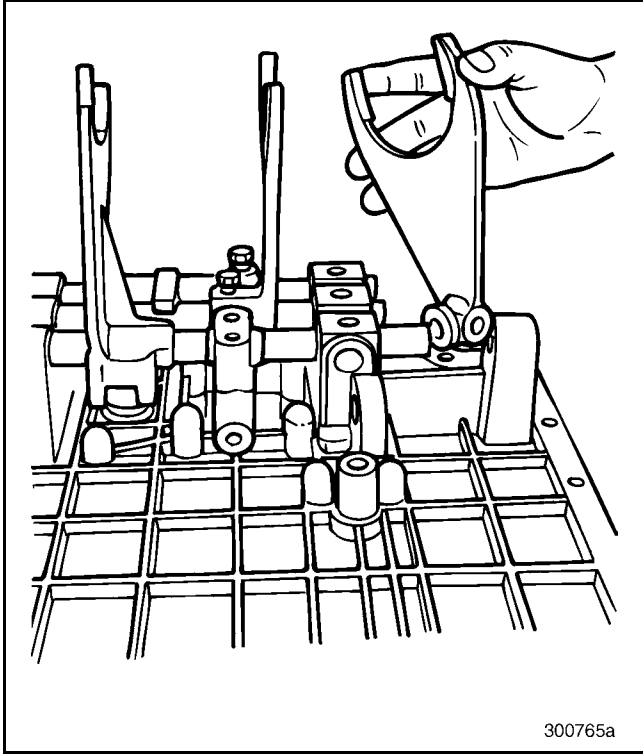

Figure 373 — Installing First/Reverse Shift Fork

23. Continue sliding the first/reverse shift rail as shown and then, install the interlock pin into the rail.

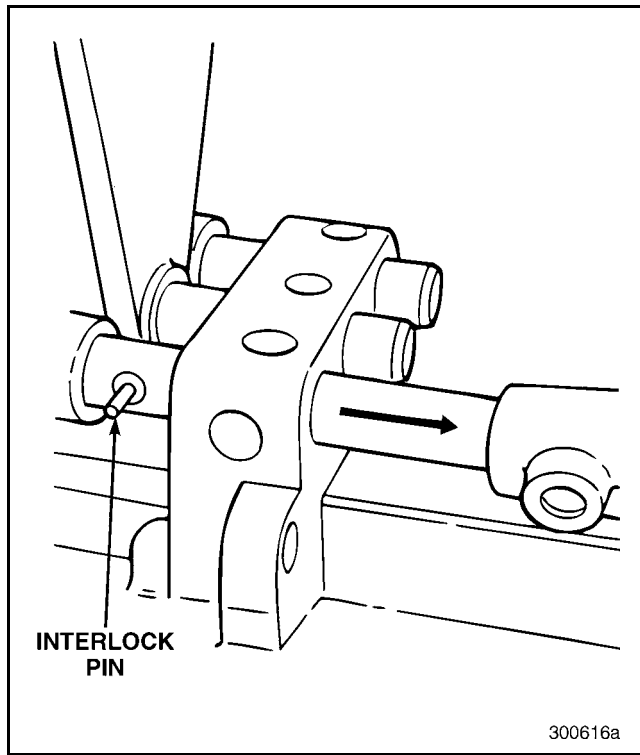

Figure 374 — Sliding First/Reverse Shift Rail

24. Finish sliding the shift rail through the fork and into position.

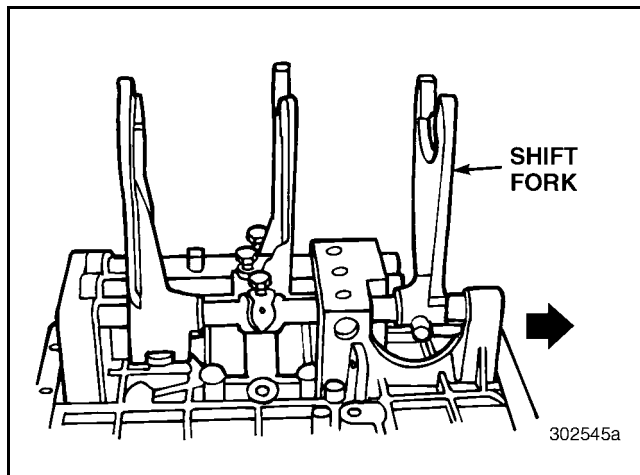

Figure 375 — Shift Rail in Position



REPAIR INSTRUCTIONS

25. Align the setscrew in the first/reverse shifter with the notch in the shift rail. Tighten the setscrew to specified torque.

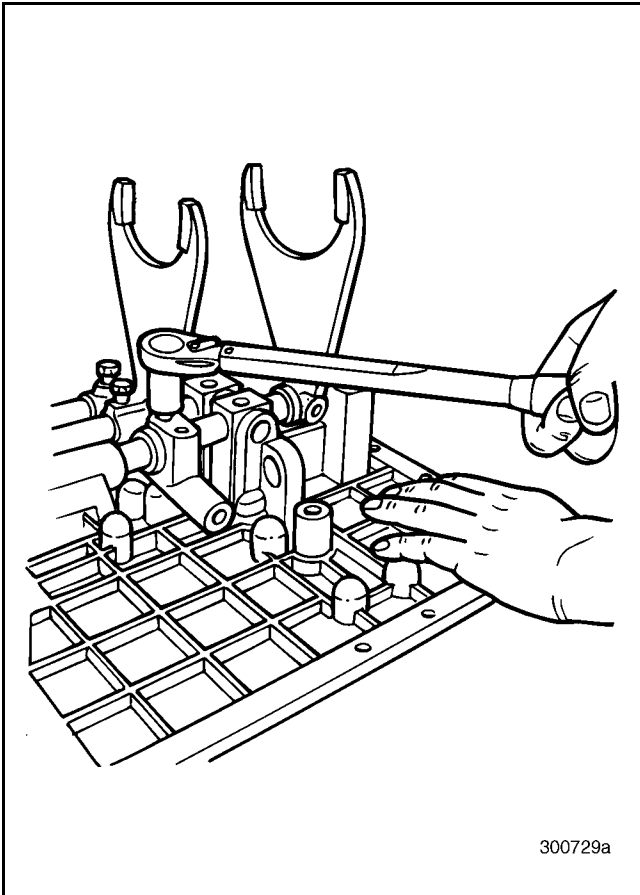

Figure 376 — Tightening Setscrew

26. Align the setscrew in the first/reverse shift fork with the notch in the shift rail. Tighten the setscrew to the specified torque.

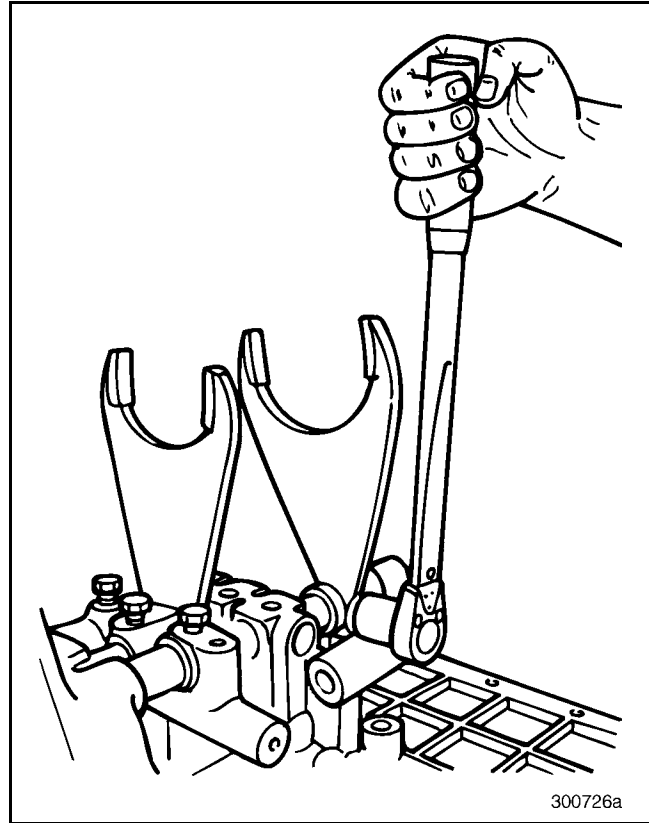

Figure 377 — Tightening Setscrew

27. Install the interlock ball into the opening next to the interlock rocker location of the cover.

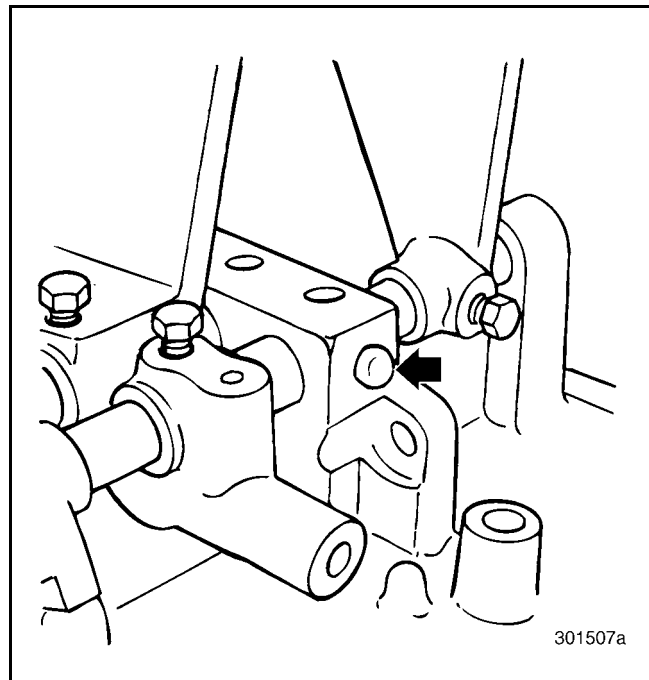

Figure 378 — Installing Interlock Ball into Cover



REPAIR INSTRUCTIONS

28. Install the interlock rocker and bolt into the cover.

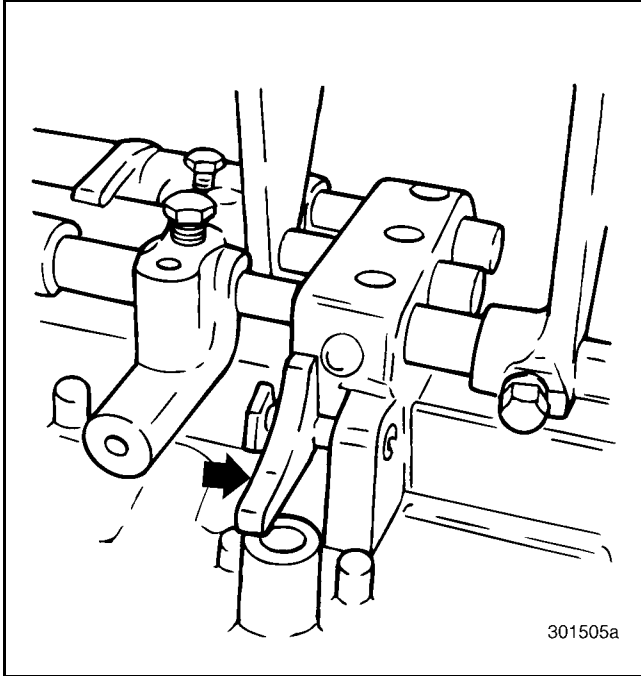

Figure 379 — Installing Interlock Rocker and Bolt

29. Install the nut and washers onto the interlock rocker bolt. Tighten to the specified torque.

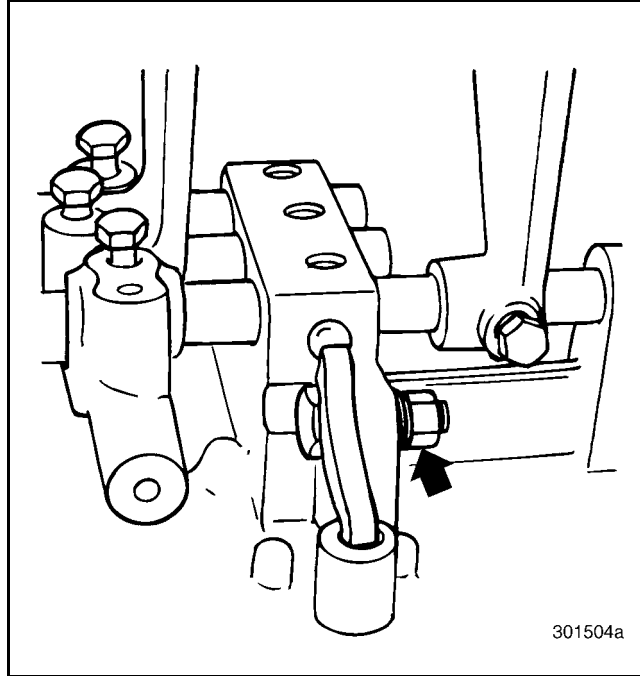

Figure 380 — Installing Nut and Washers



REPAIR INSTRUCTIONS

TRANSMISSION REASSEMBLY PROCEDURES

[320]

SERVICE HINT

Locate the stamped letter "O" on the front of each front countershaft fifth (10th) speed gear that aligns with the keyway. Paint the **front** of the corresponding gear tooth with white paint for greater visibility when timing the countershafts later. Do this for each of the three front countershafts.

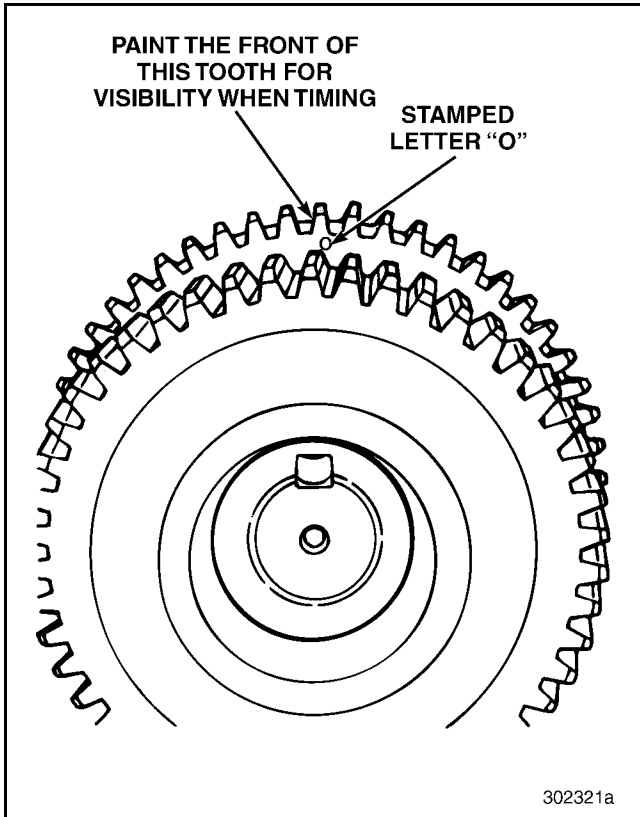

Figure 381 — Gear Tooth Marked for Timing

SERVICE HINT

Locate the three gear tooth spaces on the mainshaft fifth (10th) speed gear, stamped with the letter "O". Paint the front of each tooth **space** with white paint for greater visibility when timing the countershafts later. If there are no stamped letters, count the number of gear teeth (result should be divisible by three). Place a white paint mark on any tooth space. Then, count around one-third of the total spaces and place the second white mark. Finally, count around one-third of the total spaces again and place the third white mark. The three marks should now be evenly spaced around the gear.

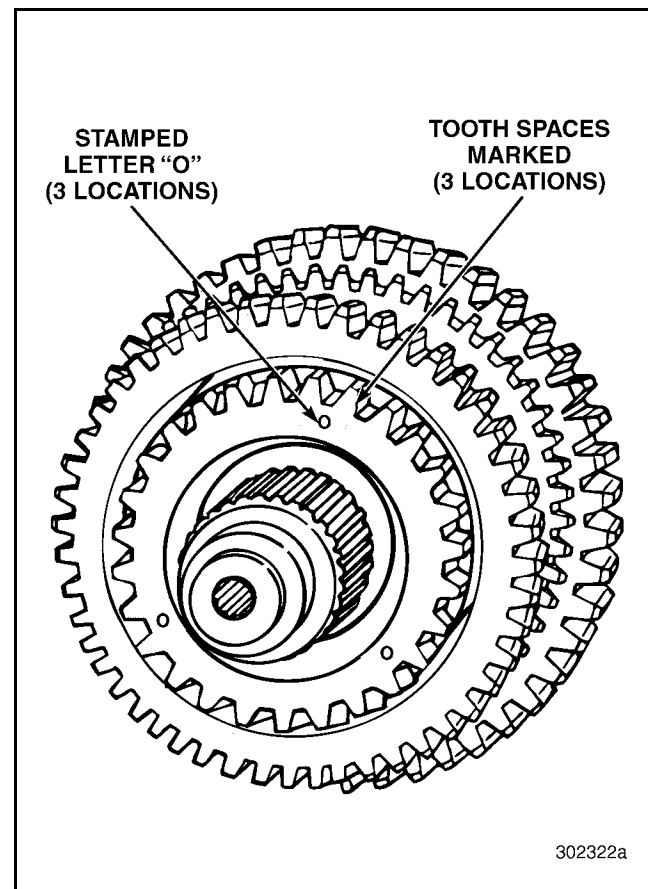

Figure 382 — Gear Tooth Spaces Marked for Timing



REPAIR INSTRUCTIONS

1. Install the No. 1 (upper right, when viewed from front) and No. 3 (lower) front countershaft front bearing covers and capscrews. Make sure **new** O-rings are in place. Tighten the capscrews to the specified torque.

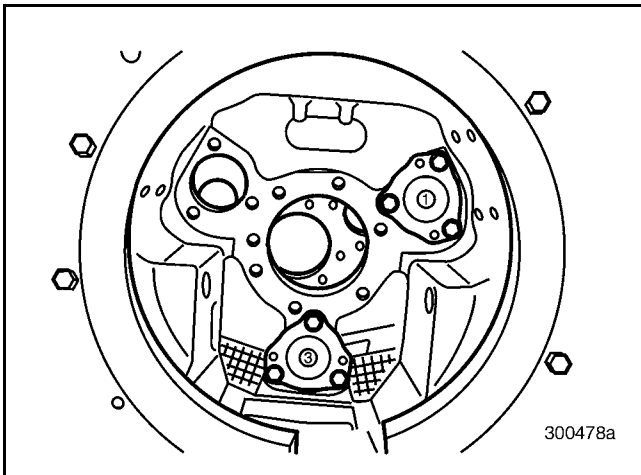

Figure 383 — No. 1 and No. 3 Front Countershaft Front Bearing Covers Installed

2. With the main case in a vertical position, front end down, install the No. 3 (lower) front countershaft into the main transmission case.

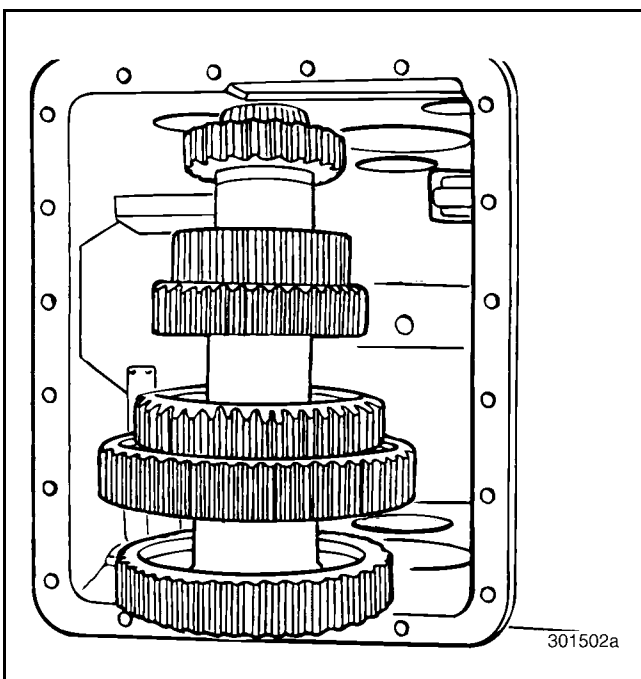

Figure 384 — Installing Lower No. 3 Countershaft into Main Case

3. Center the countershaft over the front bearing.
4. Temporarily position a shim pack over one of the front countershaft rear bearing cover openings. Mark the overhang of the shim pack at the reverse idler shaft opening of the case. This helps position the reverse idler shaft and prevents bearing cover interference with the shaft. Mark all idler shaft openings.

NOTE

The bearing cover fits into the flat on the idler shaft to retain the shaft and prevent it from rotating.

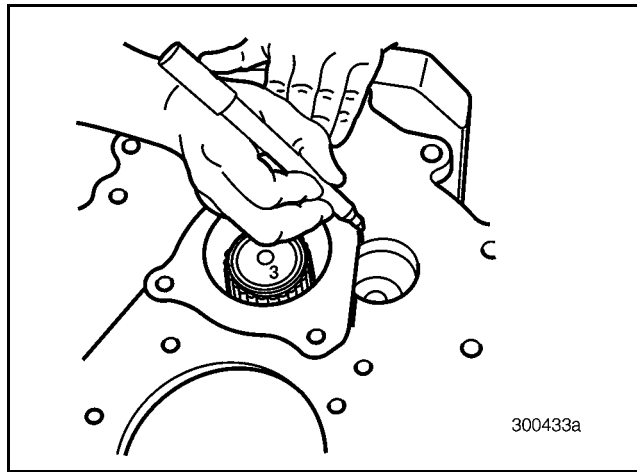

Figure 385 — Marking Idler Shaft Opening



REPAIR INSTRUCTIONS

5. Install the No. 3 (lower) reverse idler shaft into the opening provided next to the installed countershaft. As the reverse idler shaft is inserted into the case, install the reverse idler gear and thrust washer onto the shaft. The thrust washer fits on the small end of the shaft with the oil grooves of the thrust washer facing the idler gear when installed.

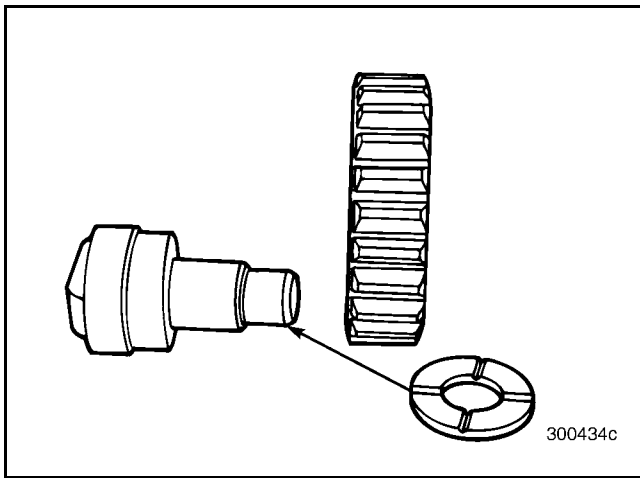

Figure 386 — Order of Reverse Idler Components

6. Align the flat on the end of the reverse idler shaft (next to No. 3 countershaft) with the mark made along the edge of the shim pack.

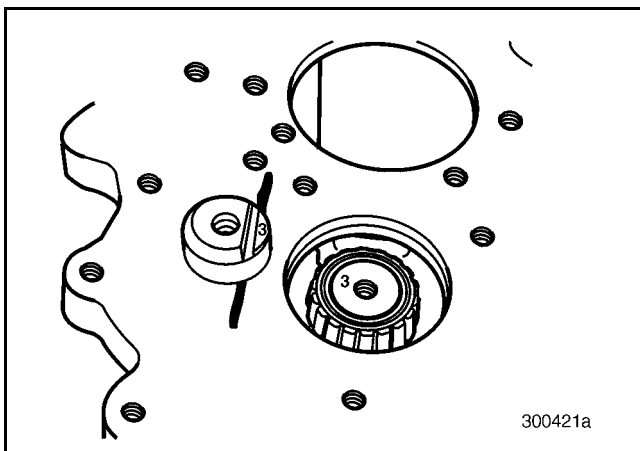

Figure 387 — Aligning Reverse Idler Shaft with Marks

7. Using a brass hammer, tap the reverse idler shaft (next to No. 3 countershaft) into the case until it bottoms (flat on idler shaft flush with case). Be sure to maintain mark alignment.

CAUTION

Make sure that the thrust washer is aligned correctly with the idler shaft while tapping the idler shaft into place. If not aligned, damage to the thrust washer may result.

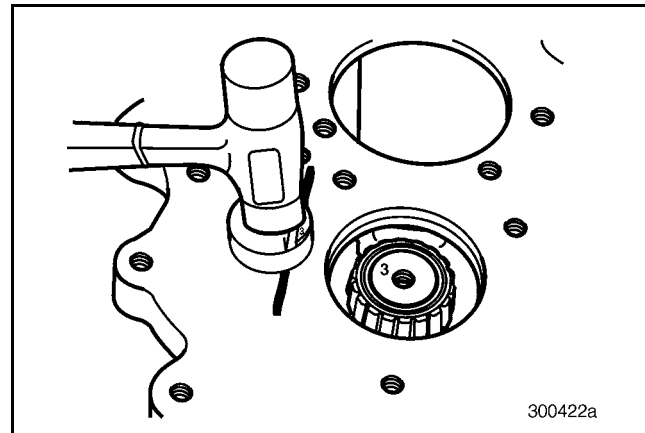

Figure 388 — Tapping Reverse Idler Shaft into Place

SETTING FRONT COUNTERSHAFT BEARING PRELOAD

8. Place the transmission in the vertical position (rear end up). Install enough shims under the No. 3 (lower) front countershaft rear bearing cover to produce measurable countershaft end play. Then install the cover and tighten the capscrews to 36–54 lb-ft (49–73 N•m) torque. Measure end play of the countershaft, using a dial indicator.

NOTE

Use a pry bar to move the countershaft up and down while measuring end play on the dial indicator.



REPAIR INSTRUCTIONS

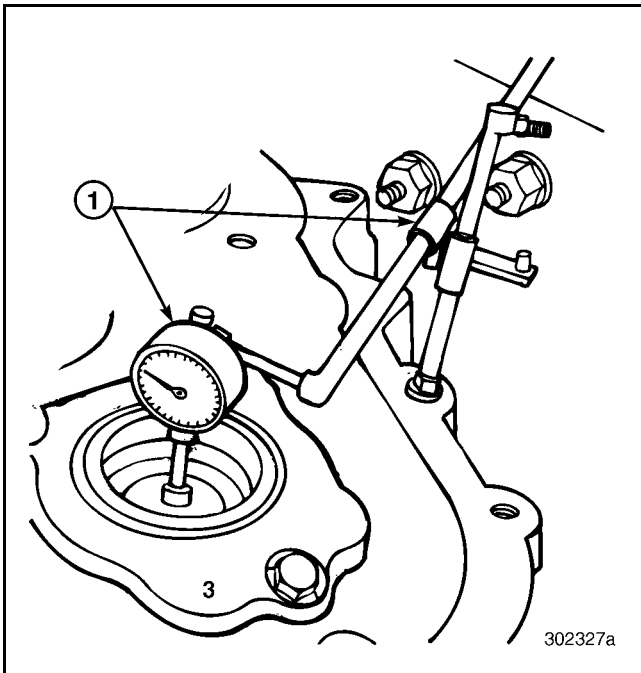

Figure 389 — Measuring Countershaft End Play

1. Dial Indicator Set J 05959-A

9. For the No. 3 (lower) countershaft, measured end play determines the thickness of shims that must be removed from the shim pack to get zero end play. Then, remove additional shim thickness to get the required 0.003 to 0.007 inch preload.

Example:

- a. Begin the procedure using enough shims under the cover to produce measurable end play.
- b. Measure countershaft end play. (For this example, end play is 0.100 inch.)
- c. Remove 0.100-inch shims from the shim pack to get zero end play.
- d. Remove (subtract) additional 0.003 to 0.007 inch shims from the pack to get the specified preload.
- e. Total shim thickness removed from the shim pack, to get 0.003 to 0.007 inch preload, must be 0.103 to 0.107 inch.

NOTE

Preload is negative end play or “crush.” It cannot be measured directly. Shim thickness must be carefully determined, as described, to obtain the correct preload on the bearings.

10. After determining the correct shim thickness, install the shim pack onto the front countershaft rear cover.

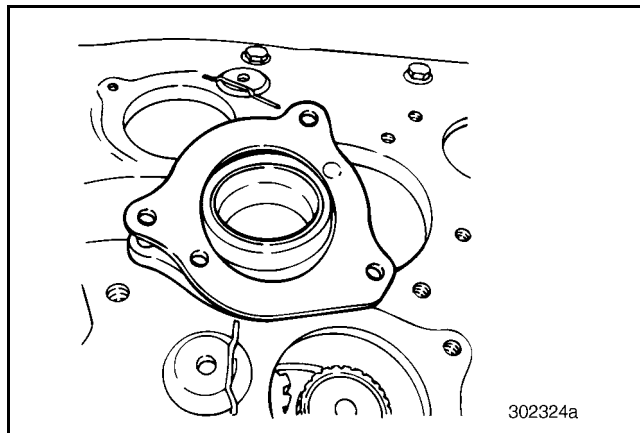

Figure 390 — Installing Shim Pack

11. Install the No. 3 (lower) front countershaft rear bearing cover by aligning and lightly tapping the cover in place. Install the capscrews and tighten to 36–54 lb-ft (49–73 N•m) torque.

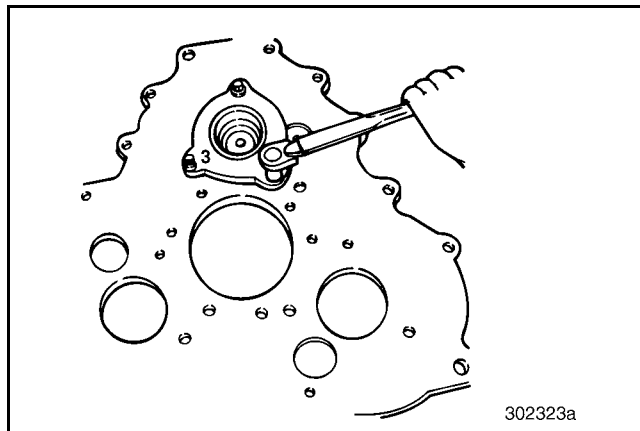

Figure 391 — Installing Countershaft Rear Bearing Cover



REPAIR INSTRUCTIONS

12. Tip the No. 1 (upper left, when viewed from the rear) front countershaft into position as described earlier for the No. 3 (lower) countershaft.
13. Install the reverse idler shaft, gear and thrust washer (next to No. 1 countershaft) as described in the steps for the lower reverse idler shaft and gear installation.
14. Pry the No. 1 (upper left) countershaft to the outside, using a suitable pry bar. Block the rear end of the countershaft off center, using a folded rag.

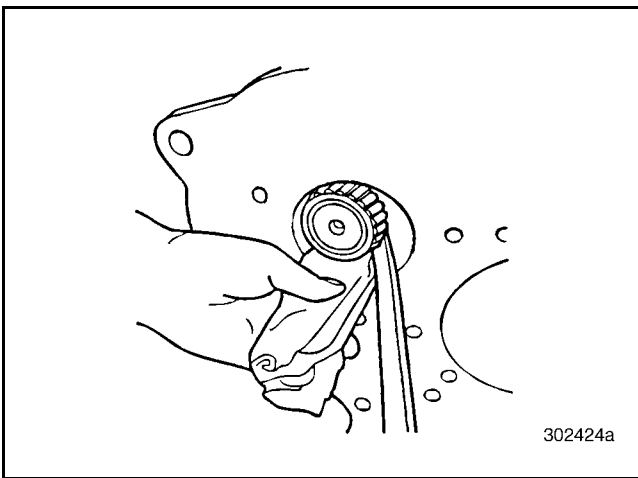

Figure 392 — Moving and Blocking No. 1 (Upper Left) Countershaft Away from Mainshaft

15. Install the mainshaft into the case.

NOTE

Before the mainshaft is installed, slide the first/reverse sliding clutch forward until it fully engages the first speed gear. Slide the reverse speed gear forward until it fully engages the sliding clutch.

WARNING

The reverse gear is not secured to the shaft and can fall off if not careful.

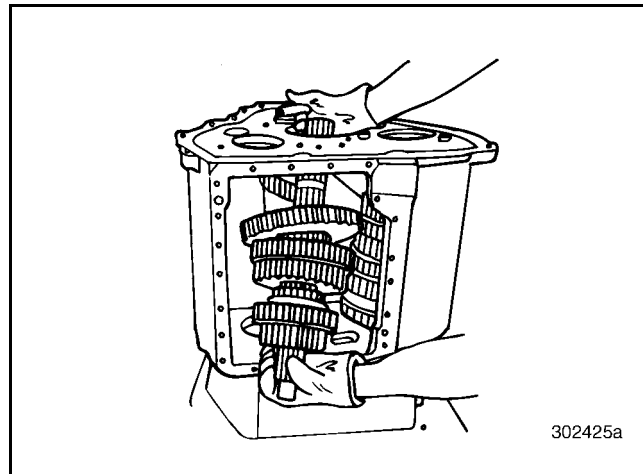

Figure 393 — Installing Mainshaft into Case

16. Place the transmission in a horizontal position.
17. Move the reverse gear and first/reverse sliding clutch to normal positions.
18. Position the mainshaft, No. 3 (lower) countershaft and No. 1 (upper right, when viewed from the front) countershaft so that the timing marks on the gears are aligned. Roll the shafts into place and make sure gear timing is correct.

SERVICE HINT

Timing the shafts is easier if the transmission is in a horizontal position, rotated 15 degrees clockwise, as viewed from the front of the transmission case.

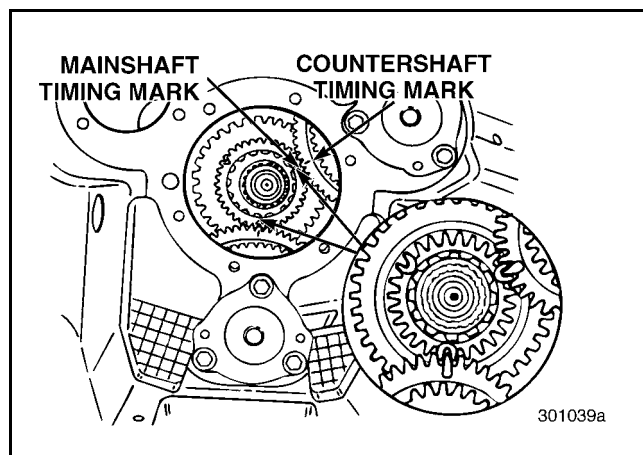

Figure 394 — Timing Gears with Mainshaft in Place



REPAIR INSTRUCTIONS

19. Install the remaining reverse idler shaft, gear and thrust washer (next to No. 2 countershaft) as described in the steps for the lower (No. 3) reverse idler shaft and gear. Move the reverse speed gear on the mainshaft as far forward as possible. When installing the reverse idler shaft and gear, make sure that the thrust washer is held in place.

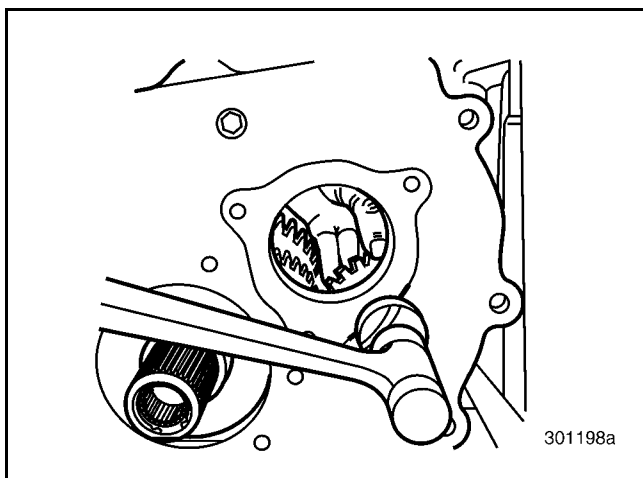

Figure 395 — Installing No. 2 Reverse Idler Shaft and Gear

20. Shift the first/reverse sliding clutch and reverse gear rearward, to allow the gear teeth on the reverse speed gear to engage all three reverse idler gears. Temporarily install a folded rag between the first and reverse speed gears to hold them in place.

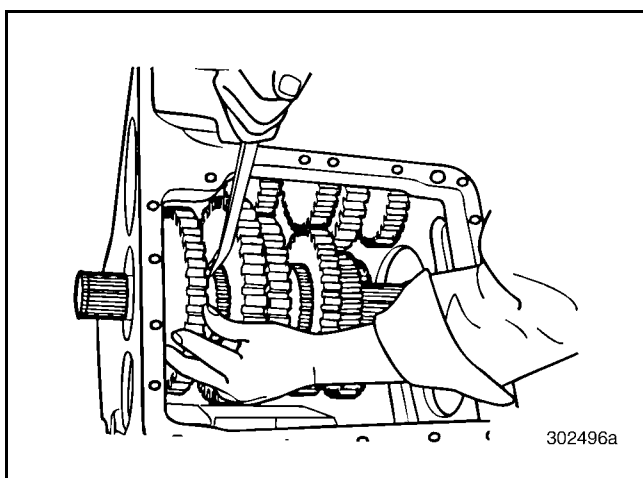

Figure 396 — Sliding First/Reverse Sliding Clutch and Reverse Speed Gear to Engage Gear Teeth

21. Install the No. 1 (upper left) countershaft rear bearing cover. Determine shim pack thickness for proper bearing preload adjustment, as described earlier for the No. 3 lower countershaft. Tighten the rear cover capscrews to the specified torque.
22. Working through the opening at the rear of the case, install the reverse speed gear mainshaft snap ring onto the shaft, if not already done. Install into third groove from rear of shaft.

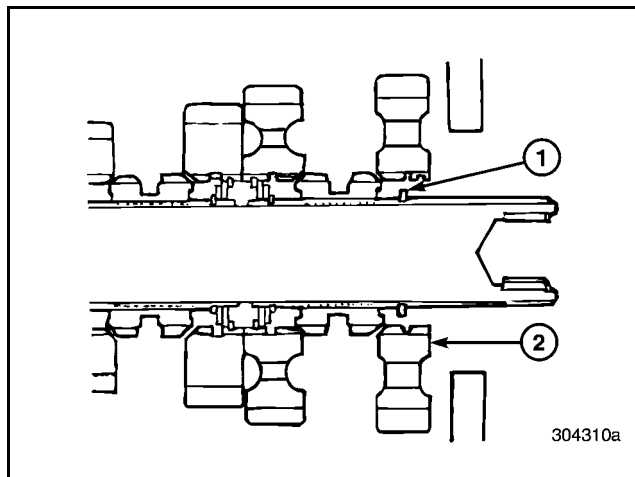

Figure 397 — Installing Reverse Gear Mainshaft Snap Ring

1. Snap Ring	2. Reverse Gear
--------------	-----------------

23. Install the internal-toothed and external-toothed thrust washers onto the mainshaft. The grooves on the external thrust washer face forward.

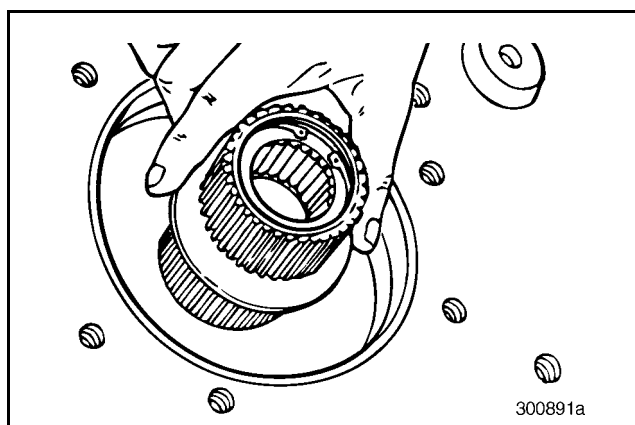

Figure 398 — Installing Internal-Toothed Thrust Washer



REPAIR INSTRUCTIONS

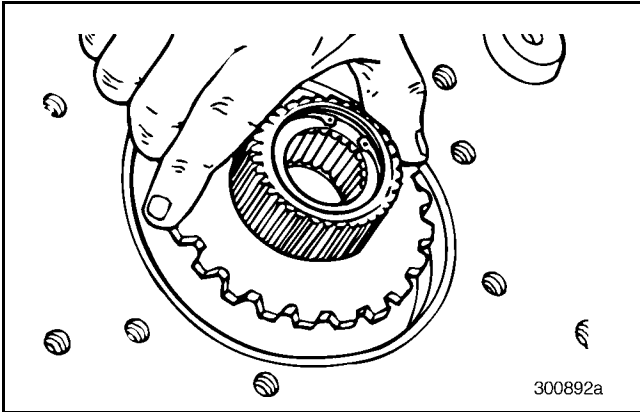

Figure 399 — Installing External-Toothed Thrust Washer

24. Install the snap ring on the inside of the reverse gear, using suitable snap ring pliers.

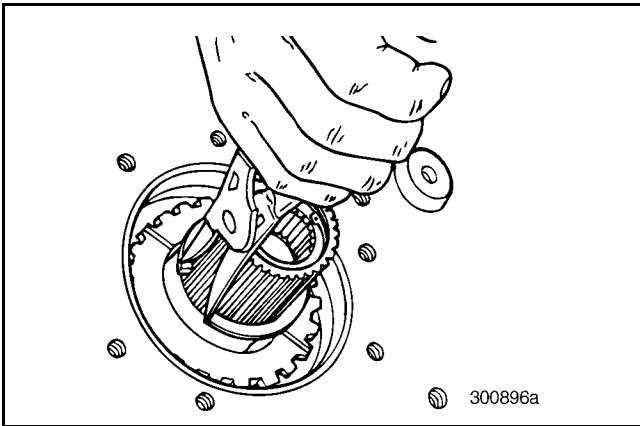

Figure 400 — Installing Reverse Gear Snap Ring

25. Install the remaining No. 2 (upper right) countershaft. Align the timing marks on the countershaft with the mainshaft. All three countershafts and mainshaft timing marks should be aligned at this point.

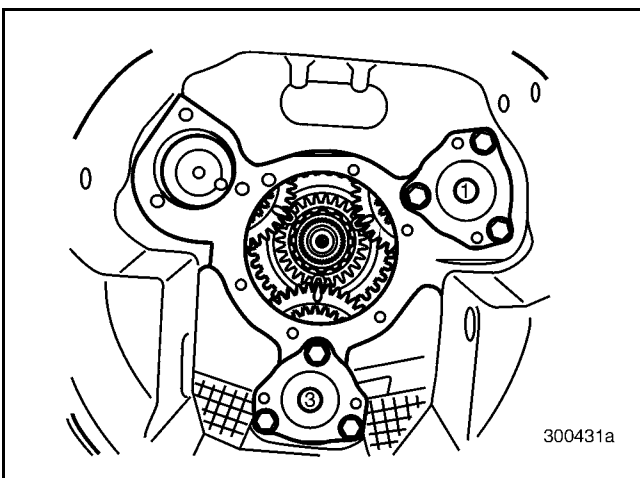

Figure 401 — Gear Timing Marks Aligned

26. Install the No. 2 (upper left, when viewed from front) countershaft front bearing cover. Pull up on the countershaft with one hand and wiggle or tap the cover into place. Tighten the cover capscrews to the specified torque.

NOTE

Do not attempt to pull any bearing cover in place, using the bearing cover capscrews. Damage to the bearings or bearing cover may result. Make sure all components are properly in place before tightening the capscrews.

27. Install the No. 2 (upper right) countershaft rear bearing cover. Determine shim pack thickness for proper bearing preload adjustment, as described earlier for the No. 3 lower countershaft. Tighten the rear cover capscrews to the specified torque.
28. Place the transmission in a vertical position, rear end up.
29. Install the mainshaft snap ring (located just behind the reverse speed gear and before the spacer) onto the mainshaft, using suitable snap ring pliers. Install into second groove from rear of shaft.

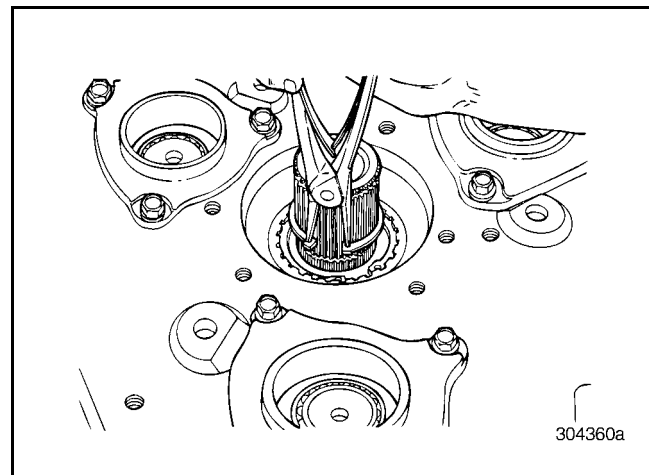

Figure 402 — Installing Spacer Snap Ring onto Mainshaft



REPAIR INSTRUCTIONS

30. Install the front mainshaft rear bearing thrust spacer onto the mainshaft, over the last snap ring. Ensure that the oil grooves face forward.

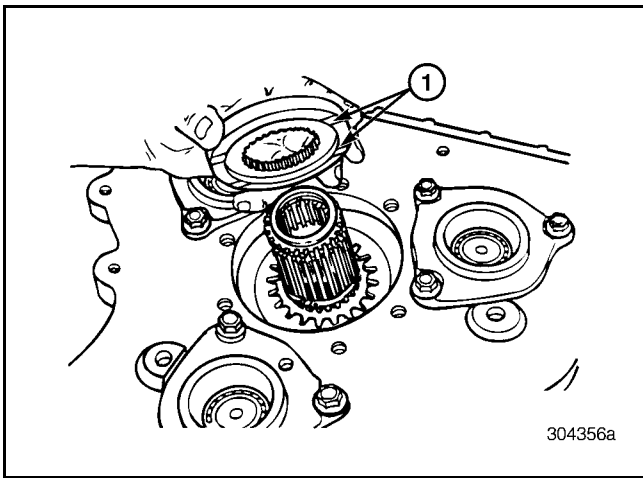

Figure 403 — Installing Spacer

1. Spacer Oil Grooves

31. Install the compound main drive gear and bearing assembly onto the front mainshaft.

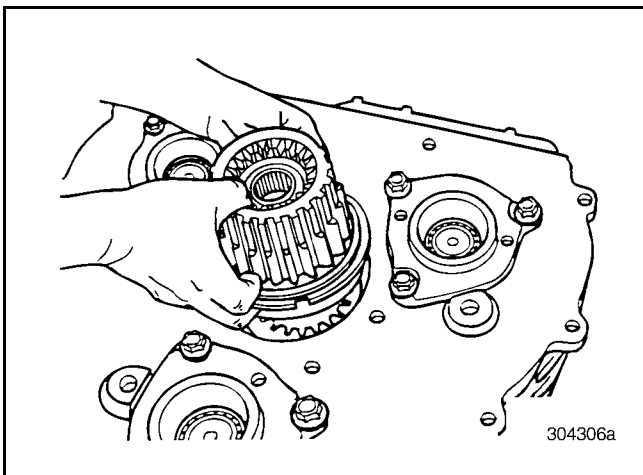

Figure 404 — Installing Rear Compound Main Drive Gear and Bearing Assembly

32. Install the snap ring securing the compound main drive gear to the front mainshaft.

SERVICE HINT

Using a pry bar, move the mainshaft rearward while holding the main drive gear. This allows extra room for the snap ring to seat in the mainshaft groove.

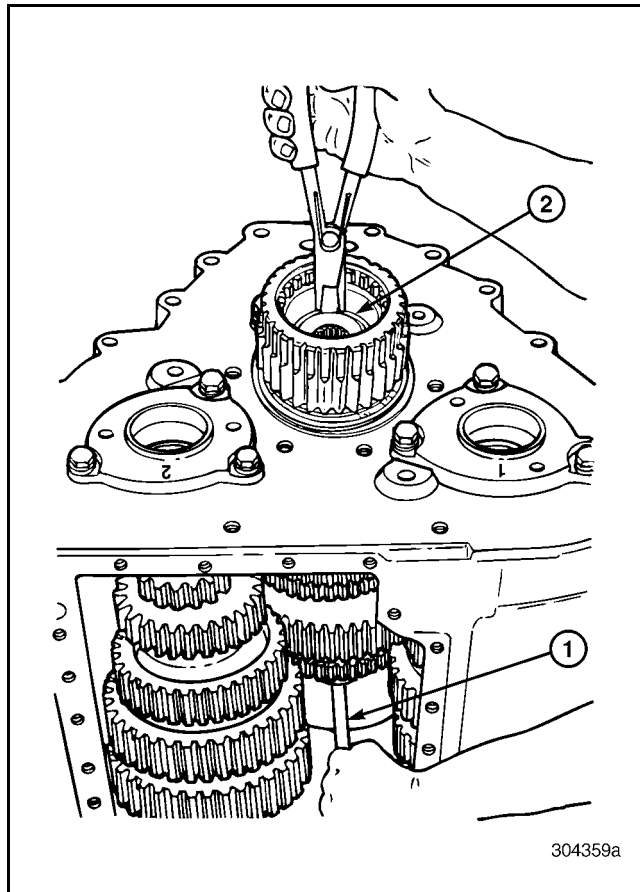

Figure 405 — Installing Main Drive Gear Snap Ring

1. Pry on End of Mainshaft 2. Install Snap Ring into Mainshaft Groove

33. Move the mainshaft forward in the case as far as possible. Install the compound main drive gear bearing cover (retaining plate).

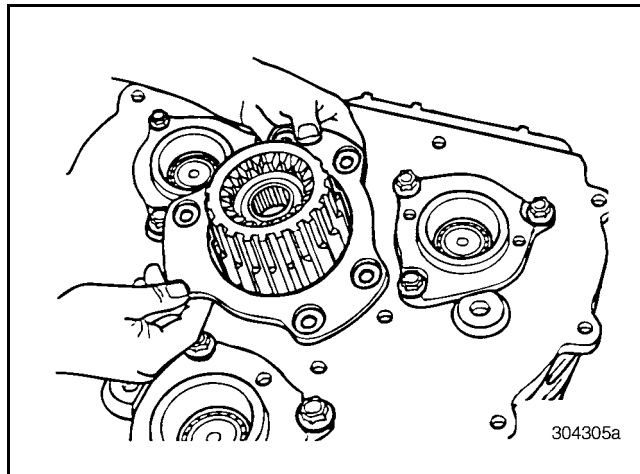

Figure 406 — Installing Compound Main Drive Gear Retaining Plate



REPAIR INSTRUCTIONS

34. Install the compound main drive gear bearing cover (retaining plate) capscrews and tighten to the specified torque.

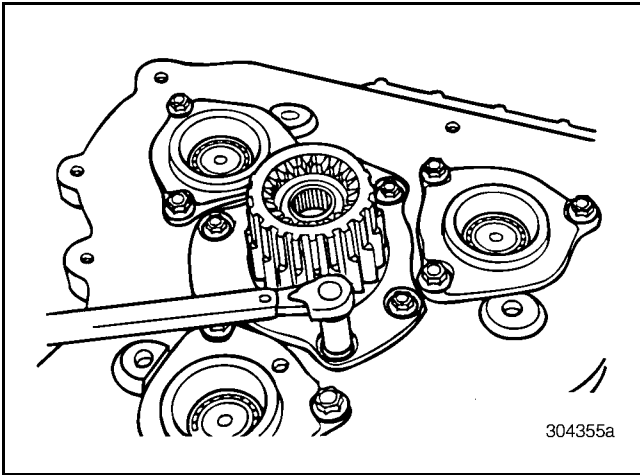

Figure 407 — Tightening Compound Main Drive Gear Retaining Plate Capscrews

35. Return the transmission to a horizontal position.
36. Working at the front of the mainshaft, install the remaining sliding clutch.

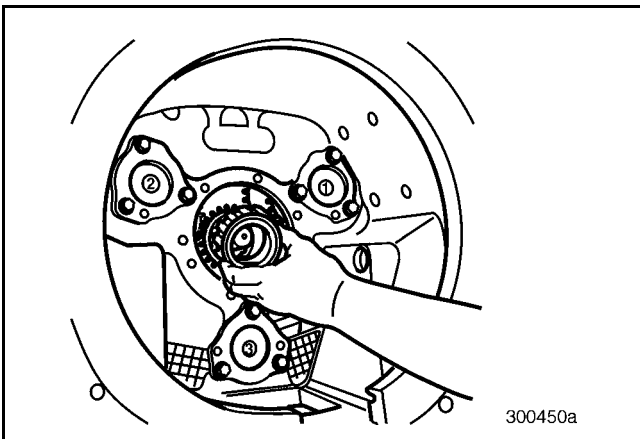

Figure 408 — Sliding Clutch and Countershaft Bearing Covers Installed

37. Install the main drive pinion bearing cover gasket. Make sure the rubber sealing material on the gasket is facing the bearing cover.

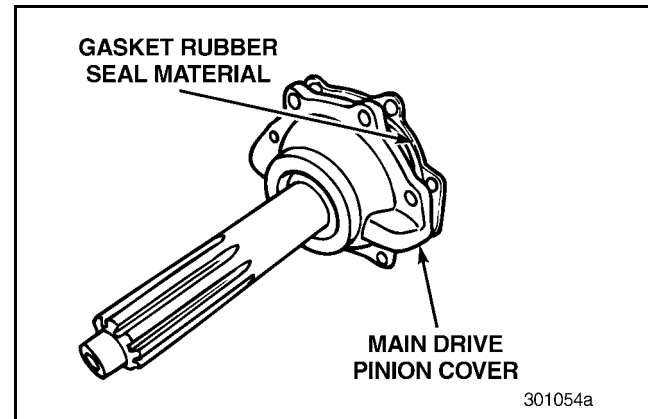

Figure 409 — Installing Cover Gasket with Sealing Material Facing Cover

38. Align the main drive pinion bearing cover gasket. Make sure the hole in the cover gasket aligns with the oil passageway in the bearing cover.

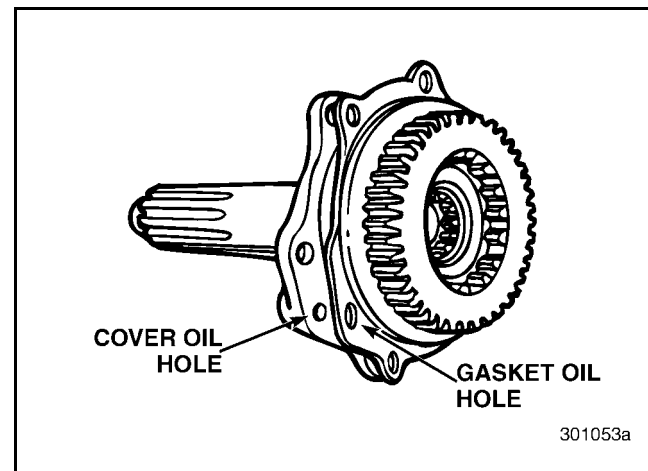

Figure 410 — Aligning Cover and Gasket Oil Holes



REPAIR INSTRUCTIONS

39. Before installing the main drive pinion assembly, make sure to align the oil passage hole in the cover with the oil passage hole in the case.

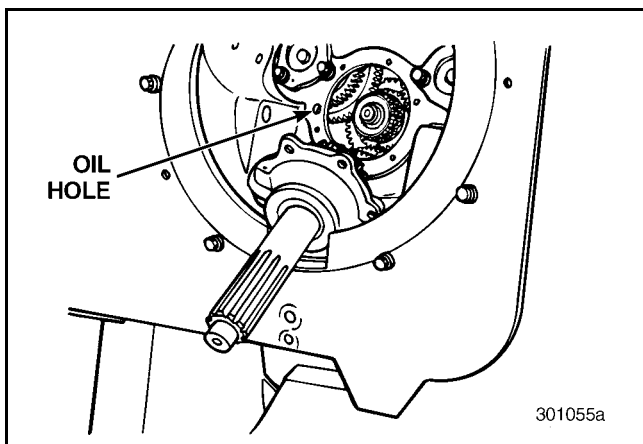

Figure 411 — Aligning Pinion Cover Oil Hole with Hole in Case

CAUTION

Make sure the oil passages in the gasket, cover and case are aligned.

40. Install the main drive pinion assembly onto the front of the case.

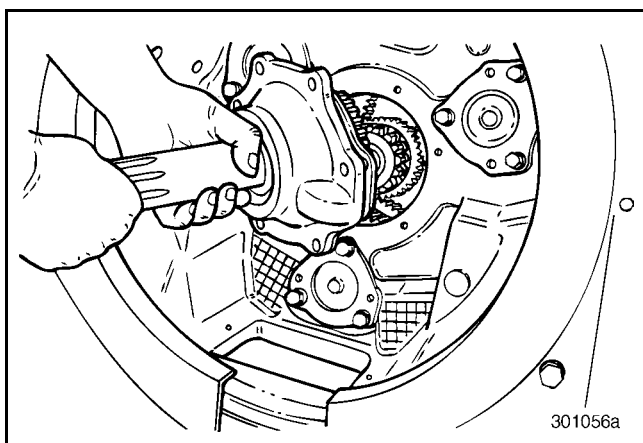

Figure 412 — Installing Main Drive Pinion

41. Install the main drive pinion bearing cover capscrews and tighten to the specified torque.

NOTE

Main drive pinions for these transmissions are designed with the equivalent of three degrees (0.069–0.071 inch or 1.753–1.803 mm) of backlash between the shaft splines and the mating splines of the main drive pinion gear. This amount of backlash was designed to eliminate a rattling noise that can occur when the engine is idling with the clutch engaged.

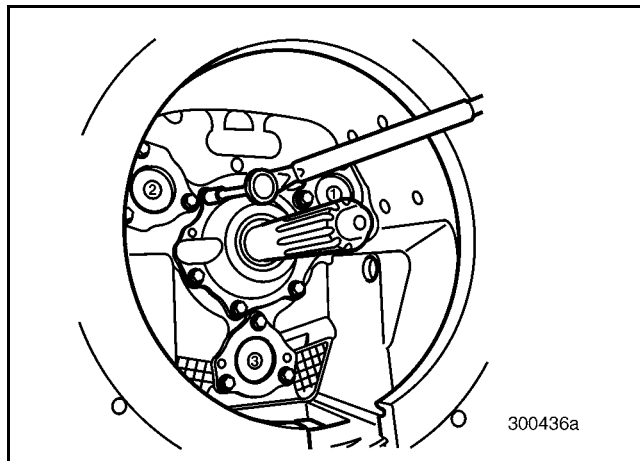

Figure 413 — Tightening Main Drive Pinion Bearing Cover Capscrews



REPAIR INSTRUCTIONS

42. Place the transmission in a vertical position, rear end up. Locate the stamped letter O on the rear face of the compound main drive gear at three tooth spaces 120 degrees apart. If there are no stamped letters, count the number of teeth (result should be divisible by three). Paint three white marks, each 120 degrees apart, on the rear face of the gear, on the tooth spaces.

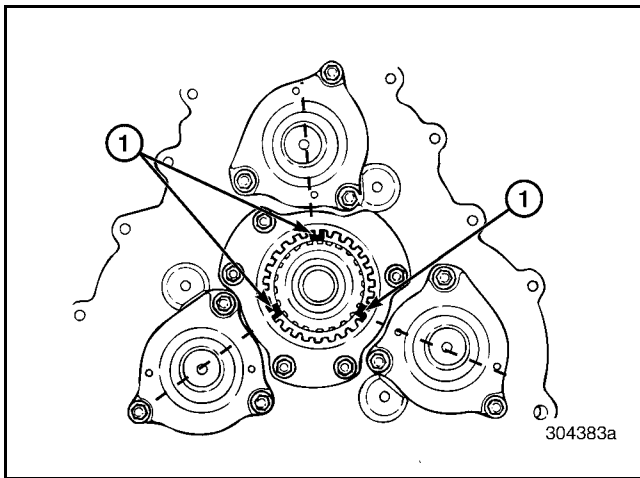

Figure 414 — Marking Compound Main Drive Gear

1. Gear Timing Marks

43. Rotate transmission mainshaft to align the three timing marks on the compound main drive gear with the approximate center lines of the three front countershafts.
44. Locate the stamped letter O on the rear face of each rear countershaft main drive gear. If there is no stamped letter, mark the gear tooth on each countershaft that is directly in line with the keyway between the gear and the countershaft. Also locate the stamped letter, or mark the teeth on the countershaft Lo-range gear and the Lo-range gear of the rear mainshaft assembly.

45. Position each of the three rear countershafts on the cup of its mating front countershaft rear bearing cover.

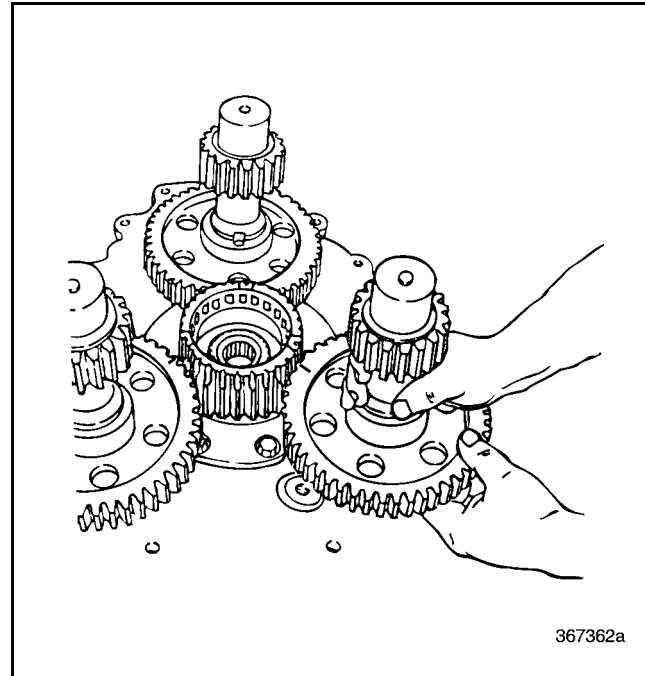

Figure 415 — Installing Rear Countershafts



REPAIR INSTRUCTIONS

NOTE

Due to the relatively small size of the rear countershaft Lo gear, it is necessary that each rear countershaft rear bearing not be installed until after mainshaft installation. If installed, the rear countershaft bearings overhang the rear mainshaft Lo gear as shown in Figure 416. Ensure that the rear countershaft rear bearings are not installed at this time.

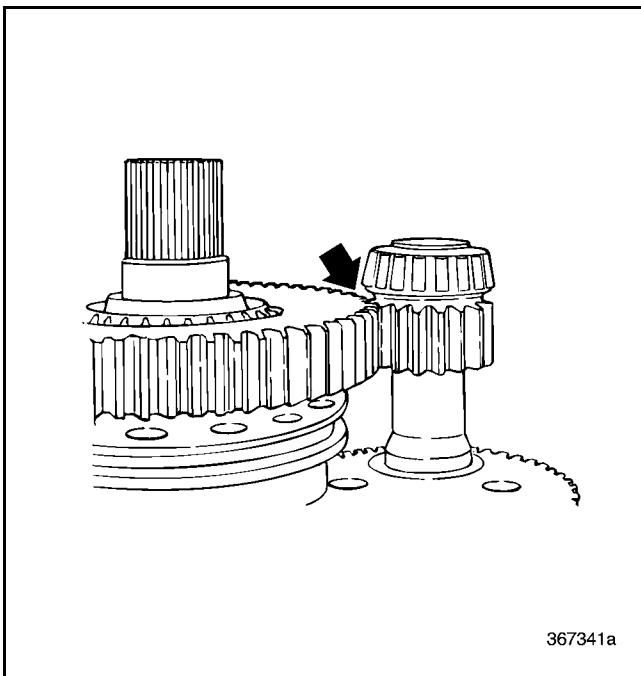

Figure 416 — Rear Countershaft Bearing Overhang

46. Align the countershaft timing marks with the timing marks on the compound main drive gear.

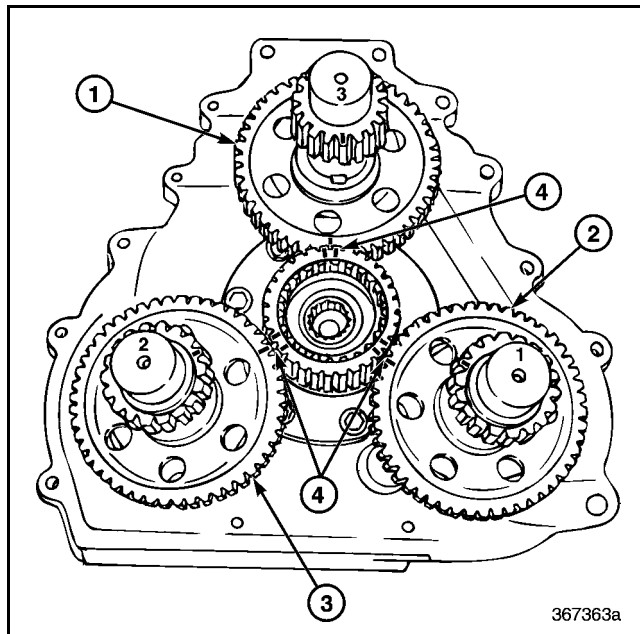

Figure 417 — Rear Countershaft and Main Drive Gear Timing Marks Aligned

- | | |
|------------------------------------|---|
| 1. Lower Countershaft (No. 3) | 3. Upper Right Countershaft (No. 2) |
| 2. Upper Left Countershaft (No. 1) | 4. Main Drive Gear-to-Countershaft Timing Marks |



REPAIR INSTRUCTIONS

47. Install the main drive gear backing plate onto the main drive gear.

NOTE

If backing plate has "R" or "Rear" stamped on one face, install that face toward the rear of the transmission. If there are no markings, install the face with sharp corner edges toward the front of the transmission.

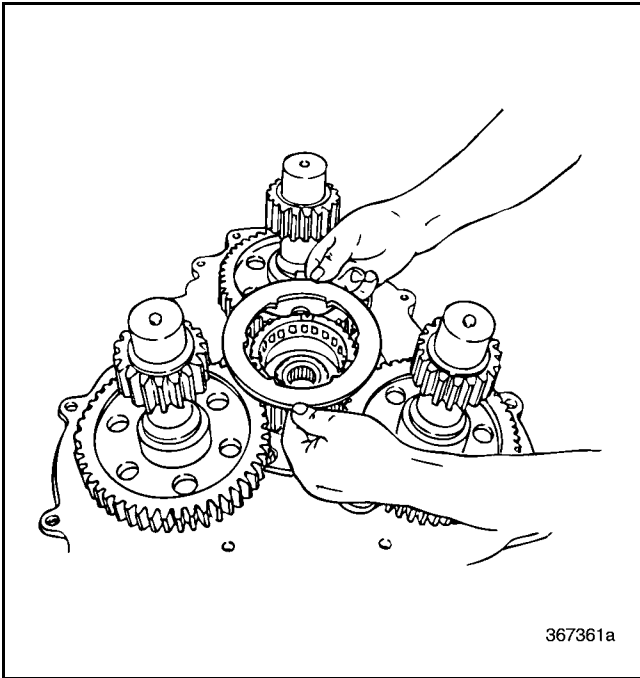

Figure 418 — Installing Main Drive Gear Backing Plate

48. Install the first synchronizer friction disc, followed by the first reaction disc. Be sure to oil both sides of each disc, using a liberal amount of gear oil.

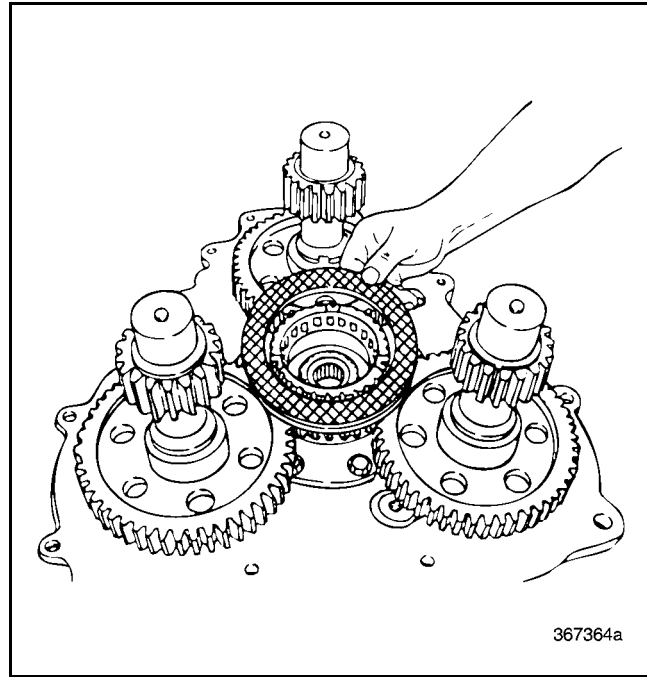

Figure 419 — Installing Synchronizer Friction Disc

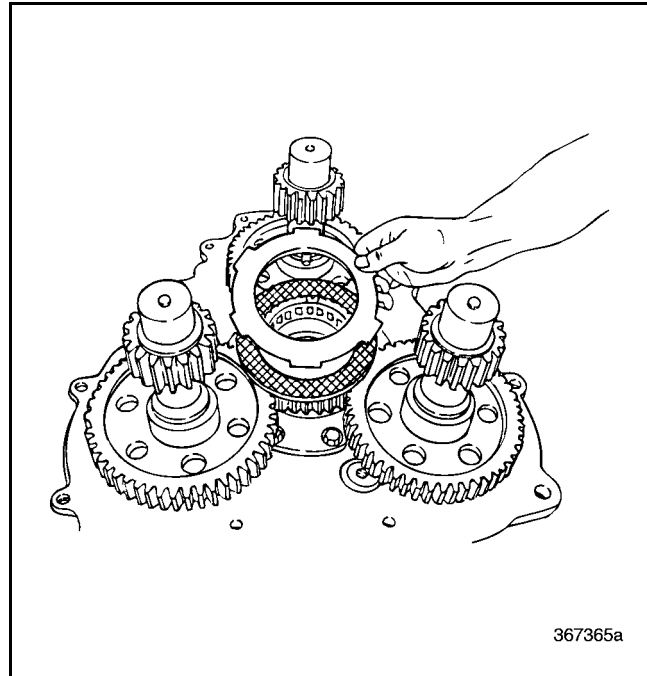

Figure 420 — Installing Synchronizer Reaction Disc



REPAIR INSTRUCTIONS

49. Continue installing the synchronizer discs, alternating types, until four of each have been installed. Apply gear oil to all friction discs during installation.
50. Align the tangs of the reaction discs with each other so that the synchronizer clutch housing slots can slide over these tangs.

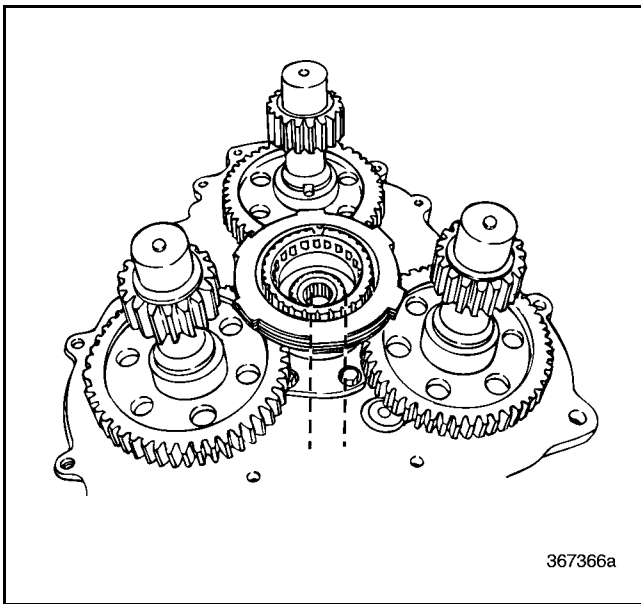

Figure 421 — Reaction Discs Aligned

51. Install the rear mainshaft and synchronizer assembly onto the main drive gear with disc pack. Ensure synchronizer clutch housing aligns with all four reaction discs.

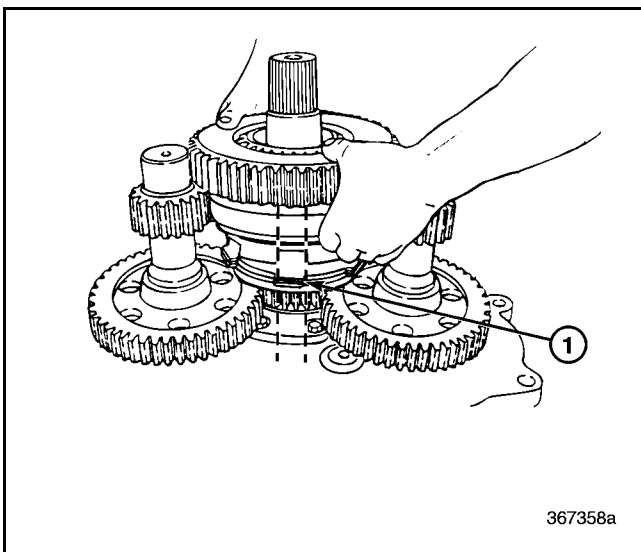

Figure 422 — Installing Rear Mainshaft and Synchronizer

1. Align Tangs with Clutch Housing

52. Check that the timing mark on each countershaft Lo-range gear aligns with the timing marks on the Lo-range gear of the rear mainshaft.
53. Install the rear bearing cones on all three rear countershafts using a suitable driver and hammer. Apply only enough force to drive the rear bearing cone on, over-driving the cone may cause damage to the forward bearing.

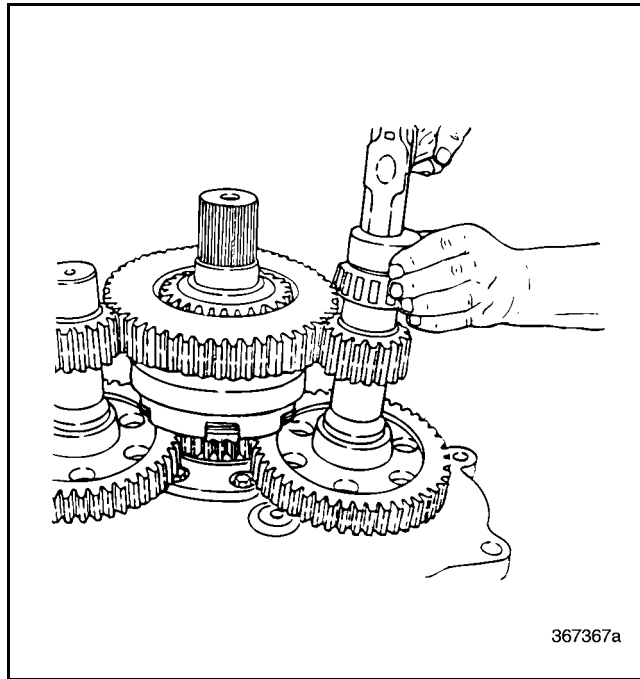

Figure 423 — Installing Countershaft Rear Bearing Cone



REPAIR INSTRUCTIONS

54. Install a **new** gasket on the gasket surface of the main case.

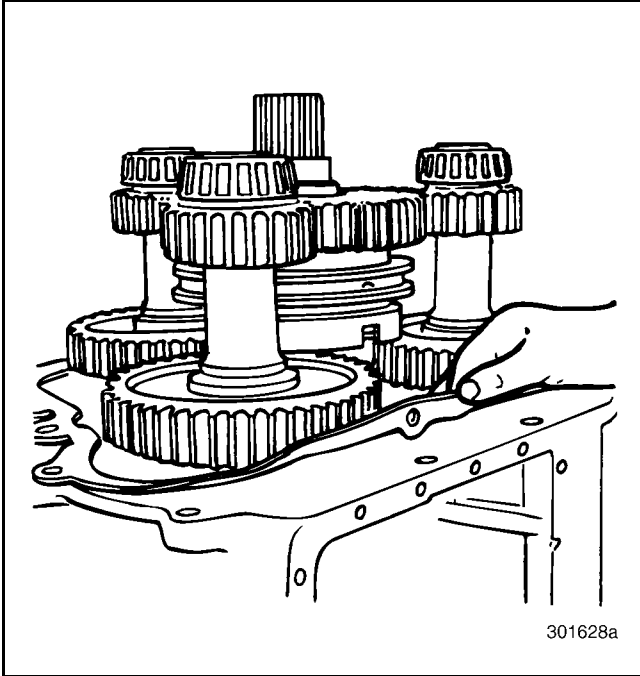

Figure 424 — Installing Rear Case Gasket

55. Install the rear case on the main case.

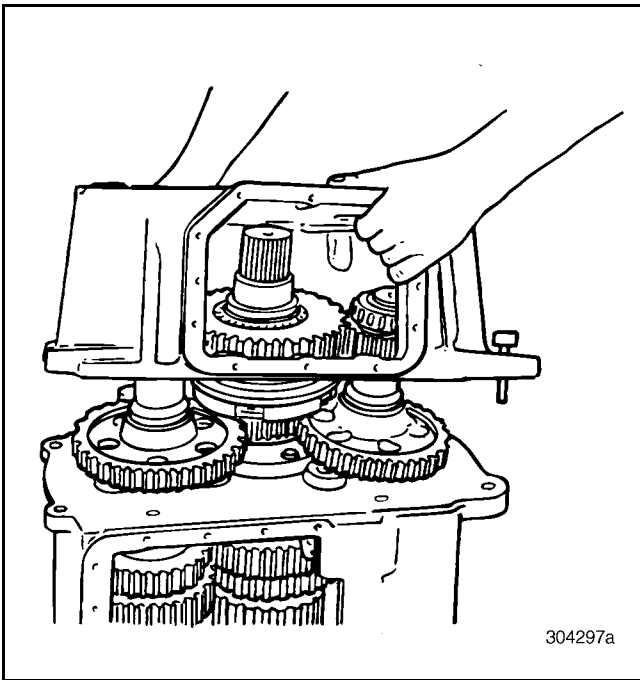

Figure 425 — Installing Rear Case

56. Install the rear case dowel bolts and nuts and tighten them to the specified torque.
57. Install the inner and outer (case-to-case) capscrews to secure the rear case to the main case. There are two inner capscrews located just inside the rear compound cover. Tighten the inner and outer case-to-case capscrews to the specified torque.

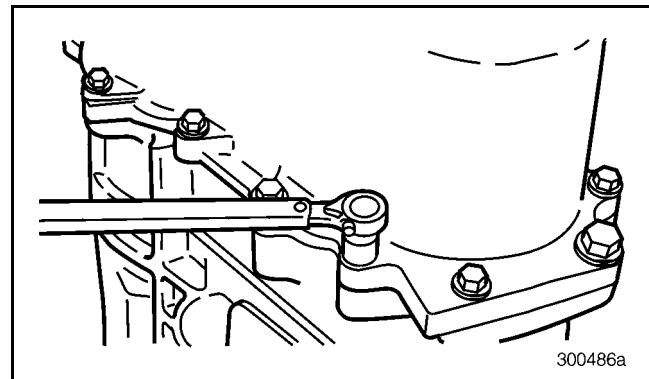

Figure 426 — Tightening Outer Case-to-Case Capscrews

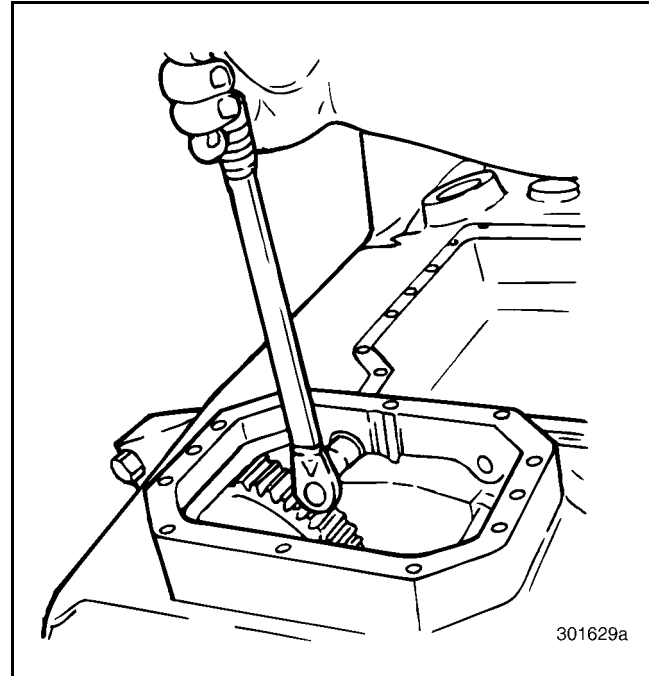

Figure 427 — Tightening Inner Case-to-Case Capscrews



REPAIR INSTRUCTIONS

58. Install a **new** gasket onto the rear mainshaft bearing cover, if not already done. Note the location of the lubrication hole.
59. Install the rear mainshaft bearing cover assembly to the rear case and secure with capscrews. Tighten the capscrews to the specified torque.

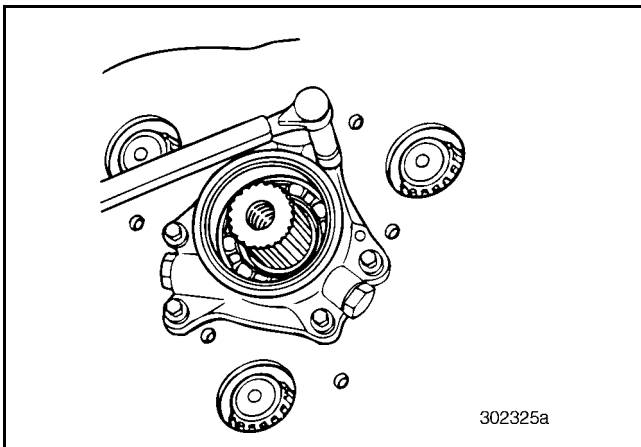

Figure 428 — Installing Rear Mainshaft Bearing Cover Assembly and Tightening Capscrews

60. Install the rear countershaft bearing covers.
61. Determine the shim pack thickness for each rear countershaft bearing preload adjustment, using the procedure described in the example that follows.
62. Working at the rear of the rear countershafts, temporarily install the rear countershaft bearing covers, leaving the capscrews loose. Do not install shim packs or O-rings at this time. Measure the space between the bearing cover and transmission case using two feeler gauge sets. Take at least two more measurements to average the results.

NOTE

A more accurate measurement can be obtained if the transmission is in a vertical position and each bearing cover is handheld firmly against the countershaft rear bearings.

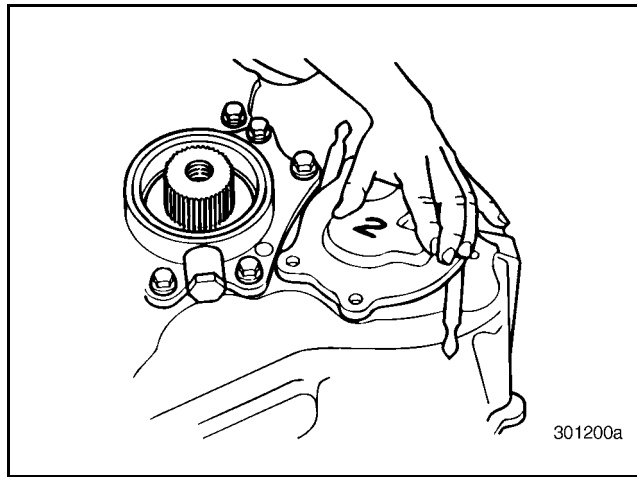

Figure 429 — Measuring to Determine Shim Pack Thickness

63. For each countershaft, remove the bearing cover and add enough shims to bring the space under the bearing cover to zero. Then remove enough shim thickness to get the required 0.002 to 0.006 inch preload.

Example:

- a. Begin the procedure using no shims or O-rings under the cover.
- b. Measure the space under the cover. For this example, the space is 0.100 inch.
- c. A 0.100-inch shim pack is needed to fill the measured space.
- d. Remove (subtract) 0.002 to 0.006 inch shims from the pack to get the specified preload.
- e. To obtain the required 0.002 to 0.006 inch preload, final shim pack thickness must be 0.094 to 0.098 inch, for this example.

NOTE

Preload is negative end play or "crush." It cannot be measured directly. Shim thickness must be determined carefully, as described, to obtain the correct preload on the bearings.



REPAIR INSTRUCTIONS

64. When all shim packs have been determined, install the rear countershaft bearing covers, shim packs, O-rings and cover capscrews. Tighten the capscrews to the specified torque. Use **new** O-rings when installing the covers.

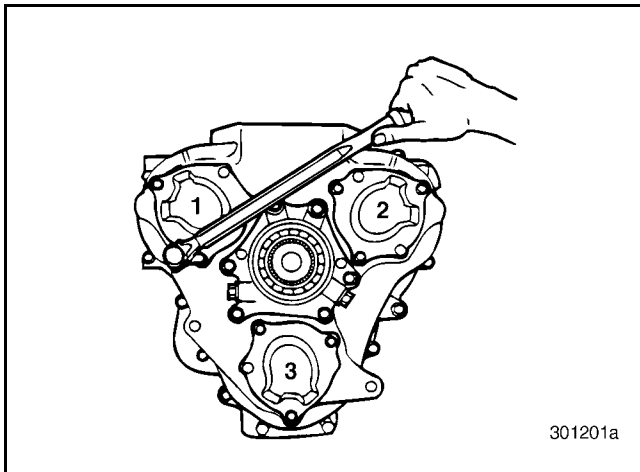

Figure 430 — Tightening Rear Countershaft Bearing Cover Capscrews

65. Return the transmission to a horizontal position.
66. Install the drive yoke, clamp plate and retaining capscrew onto the rear mainshaft.

SERVICE HINT

To install the drive yoke clamp plate and capscrew, place at least two gears in both the main case and the rear case into engagement. This is done to lock the gearing and prevent it from rotating while tightening the yoke capscrew.

67. Reach into the rear case top opening and verify that the synchronizer assembly sliding clutch is engaged.
68. Reach into the main case top opening and move at least two sliding clutches into engagement. This locks up the gearing to prevent it from turning while tightening the drive yoke capscrew.

69. Tighten the drive yoke capscrew to the specified torque. When finished, make sure all gear sliding clutches and the compound sliding clutch are returned to the normal neutral position.

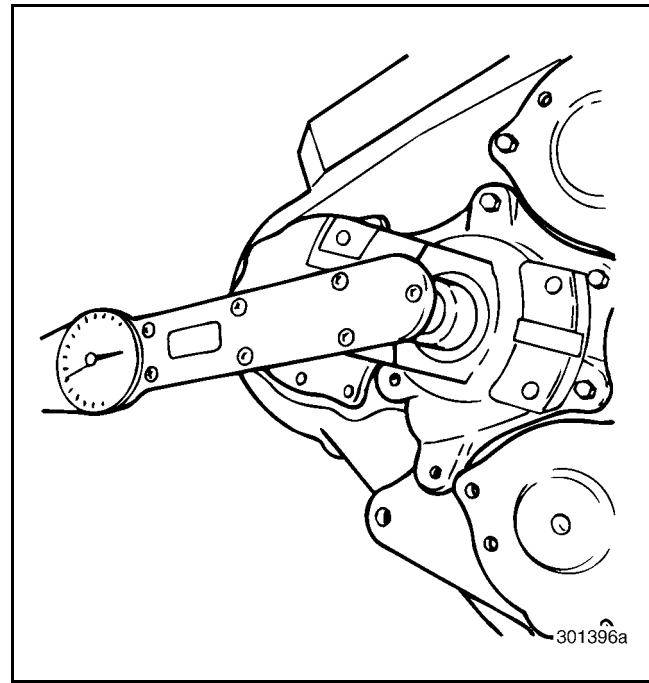

Figure 431 — Torquing Clamp Plate Capscrew

70. Position the range shift fork in the rear case with the tips of the fork inserted into the groove of the sliding clutch. The shift fork is marked with an "R." Install the fork with the "R" facing the rear of the transmission. When properly installed, the wider portion at the top of the fork is facing the rear of the transmission.

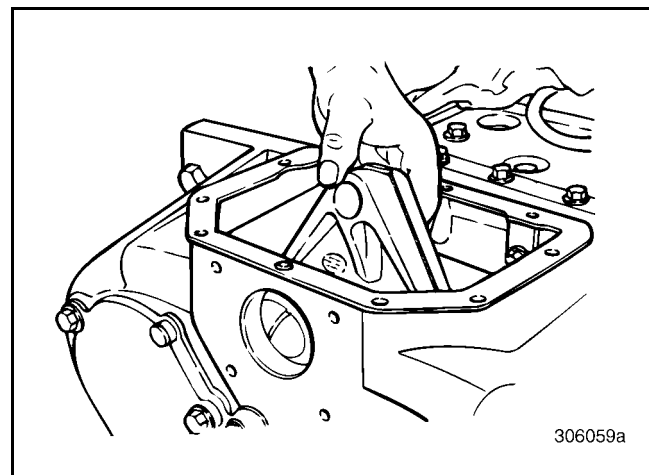

Figure 432 — Installing Range Shift Fork



REPAIR INSTRUCTIONS

71. Install a **new** gasket for the range shift cylinder housing onto the cylinder housing assembly. The red silicone bead on the gasket must face the transmission case.

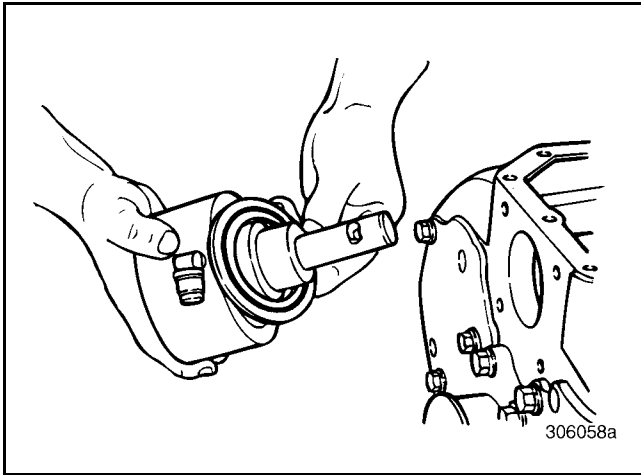

Figure 433 — Installing Shift Cylinder Gasket

72. Install the shift cylinder onto the rear case with the shift rail entering the shift fork bore. Make sure that the shift fork locking bolt hole in the rail is facing up.

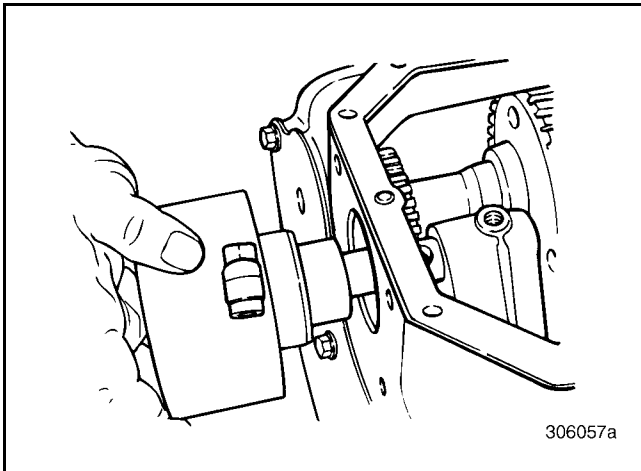

Figure 434 — Installing Shift Cylinder Assembly

73. After the cylinder has seated against the rear case, use a light plastic mallet to tap the piston further into the cylinder until the locking bolt hole in the shift rail aligns with the hole in the shift fork.

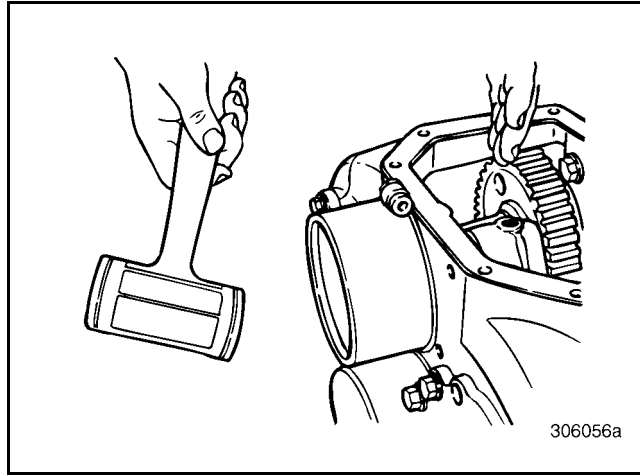

Figure 435 — Tapping Piston into Place to Align Locking Bolt Hole

74. Once the locking bolt holes are in alignment, install the bolt and tighten to specifications.

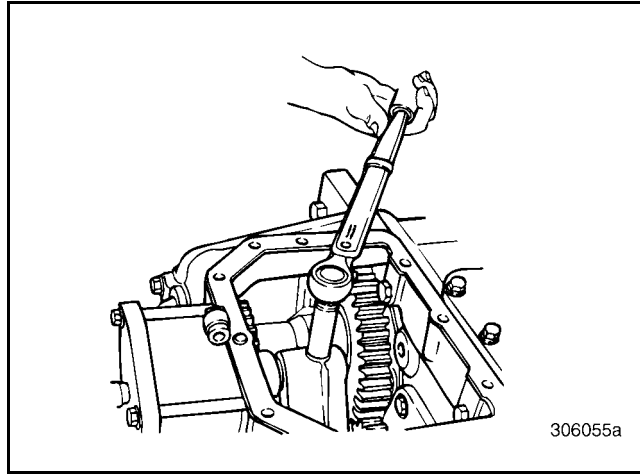

Figure 436 — Installing Shift Fork Locking Bolt



REPAIR INSTRUCTIONS

75. Apply a small amount of MACK O-ring lubricant (part No. 243SX41) to the circumference of the shift cylinder housing.

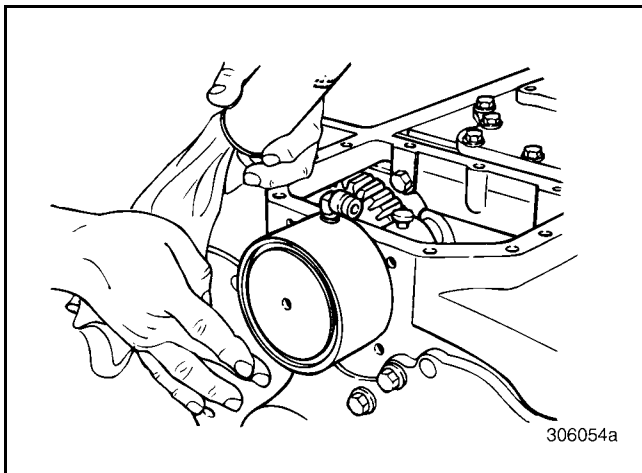

Figure 437 — Applying O-Ring Lubricant to Shift Cylinder

76. Install a **new** O-ring for the shift cylinder end cover.

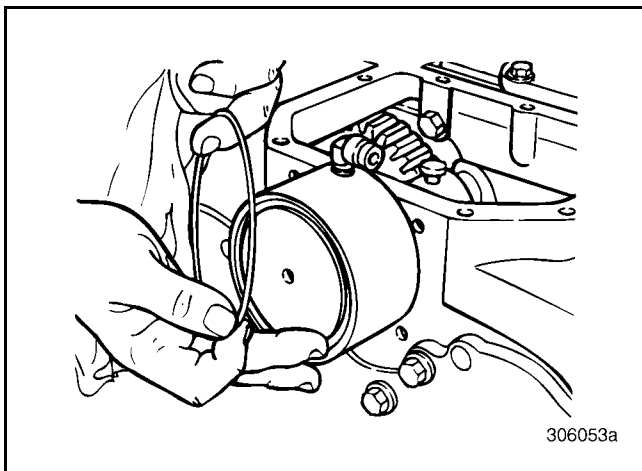

Figure 438 — Installing Cylinder End Cover O-Ring

77. Install the cylinder housing end cover and the four bolts that secure the housing assembly to the transmission rear case. Tighten the bolts to specifications.

NOTE

Do not overtighten the four long capscrews that hold the range shift cylinder cover to the rear case. Overtightening can cause the rear cover to bend.

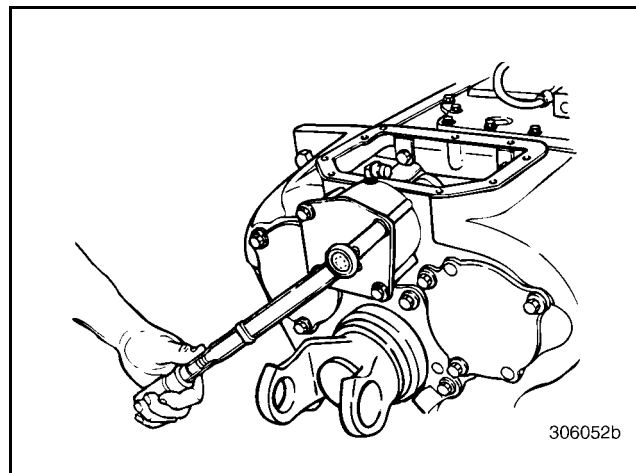

Figure 439 — Installing End Cover and Tightening Bolts

78. Clean the gasket or sealant surface of the rear case top cover and cover opening on the transmission.
79. Apply a 1/8- to 3/16-inch (0.125 to 0.1875 mm) continuous bead of Dow-Corning Silastic® 732 RTV sealant (part No. 342SX32), or equivalent, to the edges of the transmission rear cover opening. Encircle all capscrew holes as shown.

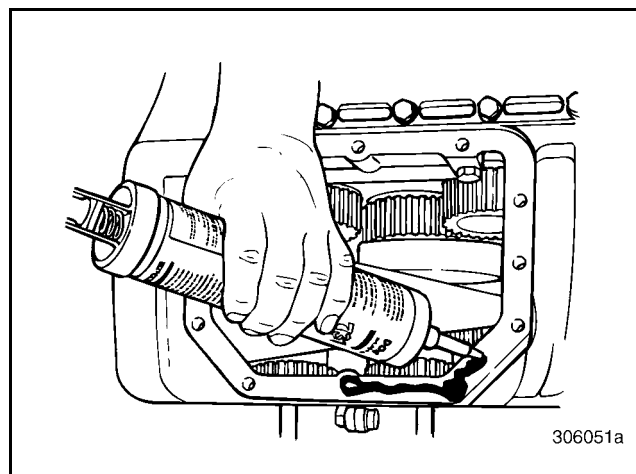

Figure 440 — Applying RTV Sealant



REPAIR INSTRUCTIONS

80. Position the rear case top cover over the previously installed RTV and align cover with rear case opening.

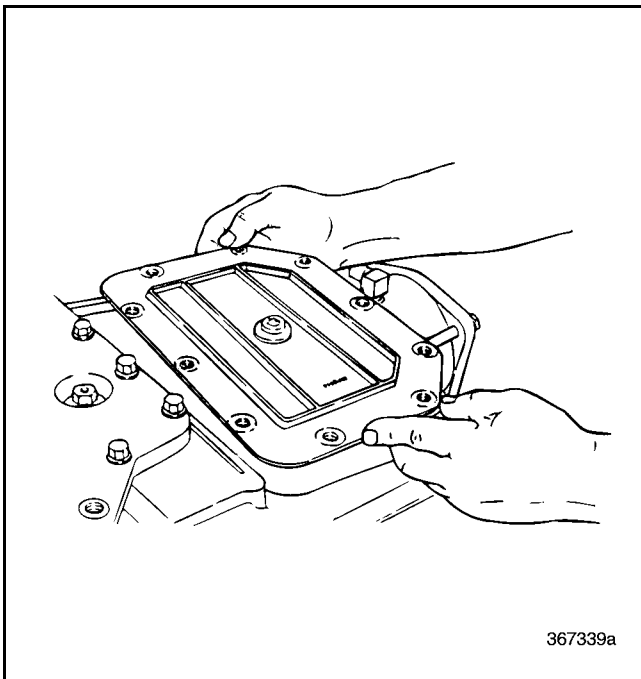

Figure 441 — Rear Cover Installation

81. Install the single short capscrew over the range shift cylinder at the center of the rear cover. If an incorrect capscrew is installed in this location, the capscrew will bottom prematurely and allow a transmission fluid leak.

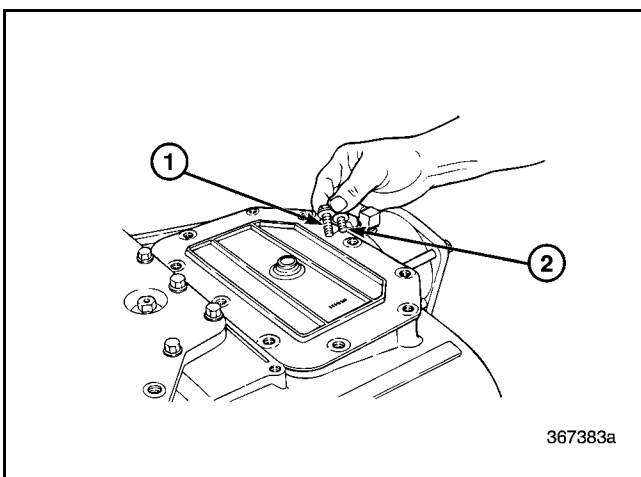

Figure 442 — Install Single Short Capscrew at Center Location

1. Cover Side Capscrew Locations

2. Cover Center Capscrew Location

82. Install the lift bracket and the longest cover capscrews at the right rear corner of the top cover, then install the remainder of the cover screws. Tighten the capscrews to the specified torque.

NOTE

The lift bracket capscrews are slightly longer than the remainder of the top cover capscrews. Make sure the longer capscrews are used to secure the lift bracket. The lift bracket is placed at the right rear corner of the shift cover.

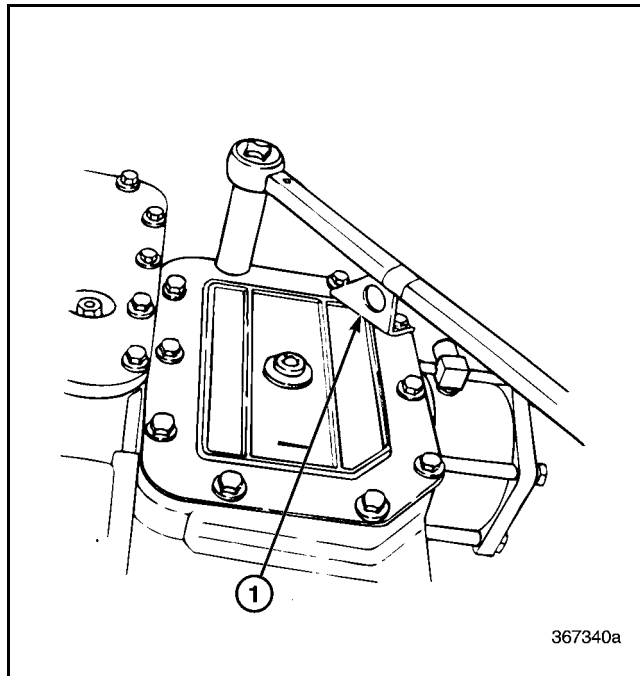

Figure 443 — Top Cover Installation

1. Rear Lift Bracket

83. Clean the gasket or sealant surface of the main case shift cover.
84. Install a **new** main case shift cover gasket. Use a small amount of adhesive or grease to hold it in place.
85. Make sure the shifters on the shift cover and the sliding clutches on the mainshaft are in the neutral position for shift fork alignment.
86. Align the shift forks with the sliding clutches and install the main case shift cover.



REPAIR INSTRUCTIONS

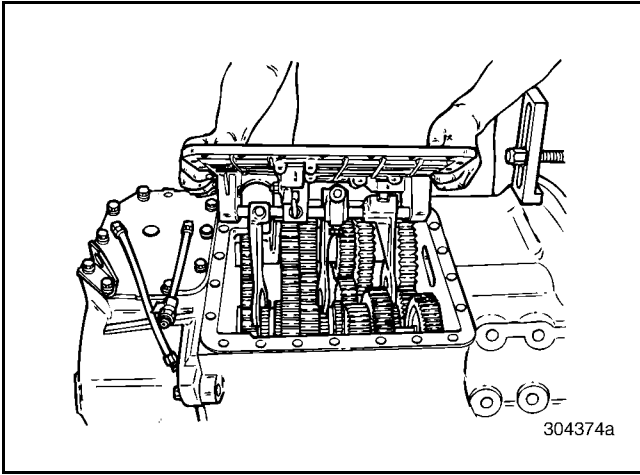

Figure 444 — Installing Main Case Shift Cover Assembly

87. Install the main case shift cover and lift bracket capscrews and tighten to the specified torque. Install the lifting bracket and longer capscrews at the left front corner of the main case shift cover as shown.

NOTE

The lift bracket capscrews are slightly longer than the remainder of the shift cover capscrews. Make sure the longer capscrews are used to secure the lift bracket.

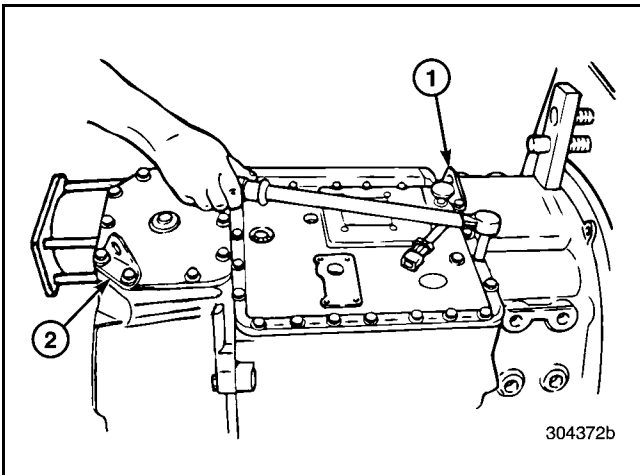

Figure 445 — Tightening Main Case Shift Cover Capscrews

- | | |
|---------------------------------|--------------------------------|
| 1. Front Lift Bracket Placement | 2. Rear Lift Bracket Placement |
|---------------------------------|--------------------------------|

88. Install the interlock O-ring, pin, spring and sleeve into the main case shift cover.

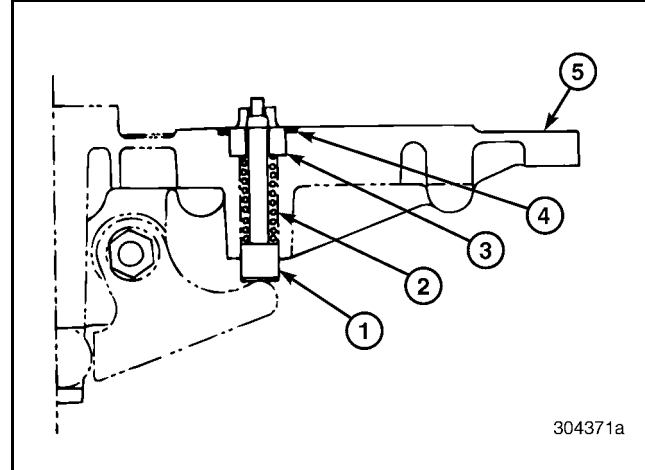

Figure 446 — Range Shift Interlock

- | | |
|---------------------|--------------------------|
| 1. Interlock Pin | 4. O-Ring |
| 2. Interlock Spring | 5. Main Case Shift Cover |
| 3. Interlock Sleeve | |

89. Position the range shift valve over the tip of the lock pin. Install the two (outer) Allen-head 5/32-inch screws and torque to specification.

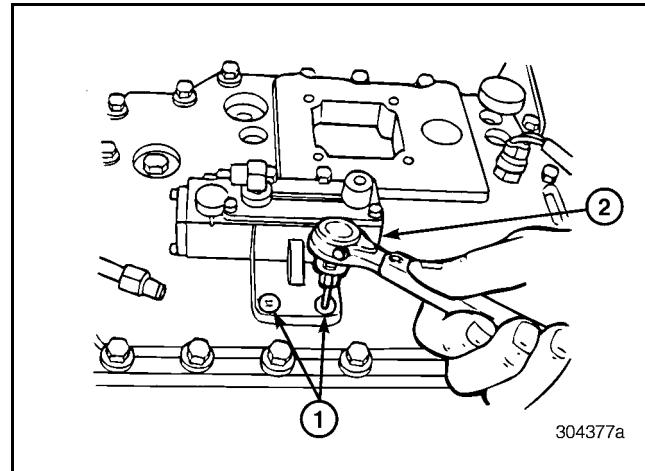

Figure 447 — Tightening Range Shift Valve Screws

- | | |
|----------------------------------|----------------------|
| 1. Allen-Head Screws (5/32 inch) | 2. Range Shift Valve |
|----------------------------------|----------------------|



REPAIR INSTRUCTIONS

90. Install the two (inner) hex-head screws and torque to specification.

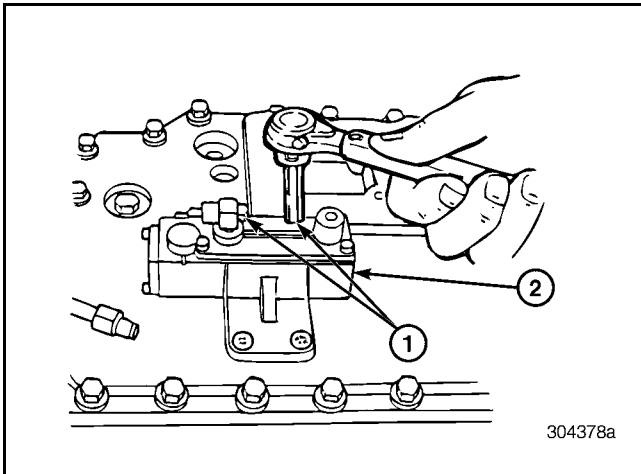

Figure 448 — Tightening Remaining Range Shift Valve Screws

1. Hex-Head Screws	2. Range Shift Valve
--------------------	----------------------

91. Reconnect the air lines attached to the range shift cylinder and the range shift valve. Refer to "SCHEMATIC DIAGRAMS" on page 178.
92. Install the transmission drain plug and magnetic filter plug and torque to specifications.
93. Install the clutch release bearing assembly, shafts, yoke and clutch brake (if equipped).
94. Reinstall the transmission into the chassis of the vehicle.
95. Fill the transmission to the proper fill level, using the recommended lubricant. Refer to "Transmission Specifications and Capacities" on page 176.
96. Install and tighten the filler plug to specification.

RANGE SHIFT VALVE CHECK

97. Reconnect all remaining air lines and gear shift linkage/gear shift lever.
98. Check range shift valve operation to make sure that the compound range shift can occur only when in neutral.



SPECIFICATIONS

SPECIFICATIONS



SPECIFICATIONS

SPECIFICATIONS

Torque Specifications

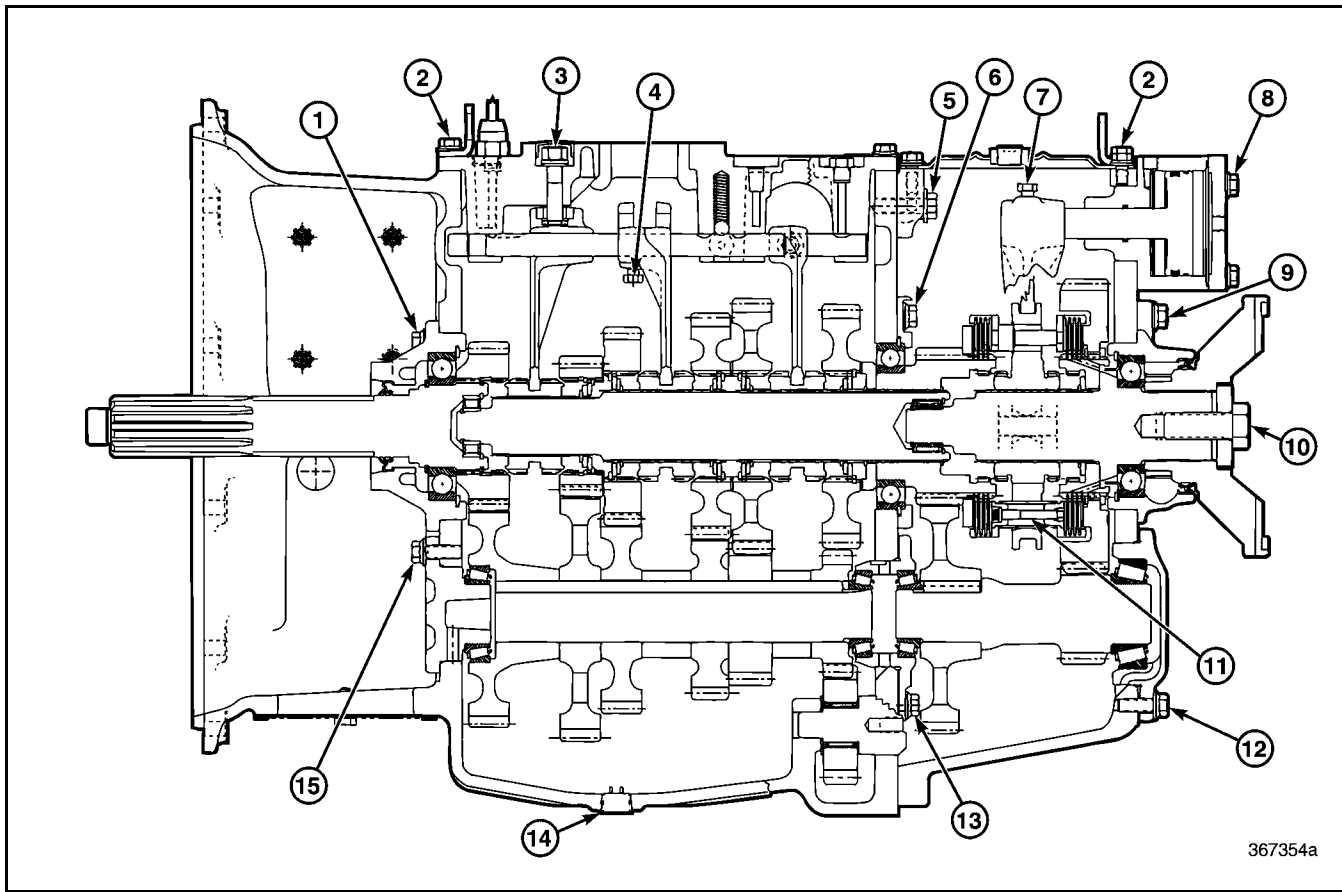

Figure 445 — Torque Specifications



SPECIFICATIONS

Item and Location	Torque — Lb-Ft (N•m)
1. Main Drive Pinion Bearing Cover Capscrews*	36–54 (49–73)
2. Shift Cover Capscrews (Main Case/Rear Case)*	24–36 (33–49)
3. Fourth/Fifth Pin Locknut	40–50 (54–68)
4. Shifter and Shift Fork Setscrews	35–50 (47–68)
5. Front Case-to-Rear Case Capscrews	62–78 (84–106)
5. Front Case-to-Rear Case Dowel Bolt	55–65 (75–88)
6. Compound Main Drive Gear Bearing Retaining Plate Capscrews	40–50 (54–68)
7. Range Shift Piston/Fork Capscrew	35–50 (47–68)
8. Range Shift Cylinder Cover Capscrews*	17–21 (23–29)
9. Rear Mainshaft Bearing Cover Capscrews*	40–50 (54–68)
10. Drive Flange (or Yoke) Clamp Plate Capscrews	494–600 (670–814)
11. Synchronizer Special 12-Point Screws (Quantity 3)	24–28 (33–38)
12. Rear Countershaft Bearing Cover Capscrews*	40–50 (54–68)
13. Front Countershaft Rear Bearing Cover Capscrews	36–54 (49–73)
14. Drain Plug	25–30 (34–41)
15. Front Countershaft Front Bearing Cover Capscrews*	36–54 (49–73)
— Oil Filler Plug	35–50 (47–68)
— Magnetic Filter Plug	20–23 (27–31)
—Transmission Case Eight-Hole PTO Cover Capscrews*	36–54 (49–73)
—Transmission Case Six-Hole PTO Cover Capscrews*	24–36 (33–49)
— Range Shift Interlock Rocker	20–25 (27–34)
— Range Shift Valve Mounting Screws (Two Hex, Two Allen)*	84–96 lb-in (9–11)
— Range Shift Valve Top Cover and End Cover Screws	30–40 lb-in (3.4–4.5)

* Indicates that fastener has epoxy-coated threads. Fastener can be reused a maximum of five times.



SPECIFICATIONS

Gear Identification

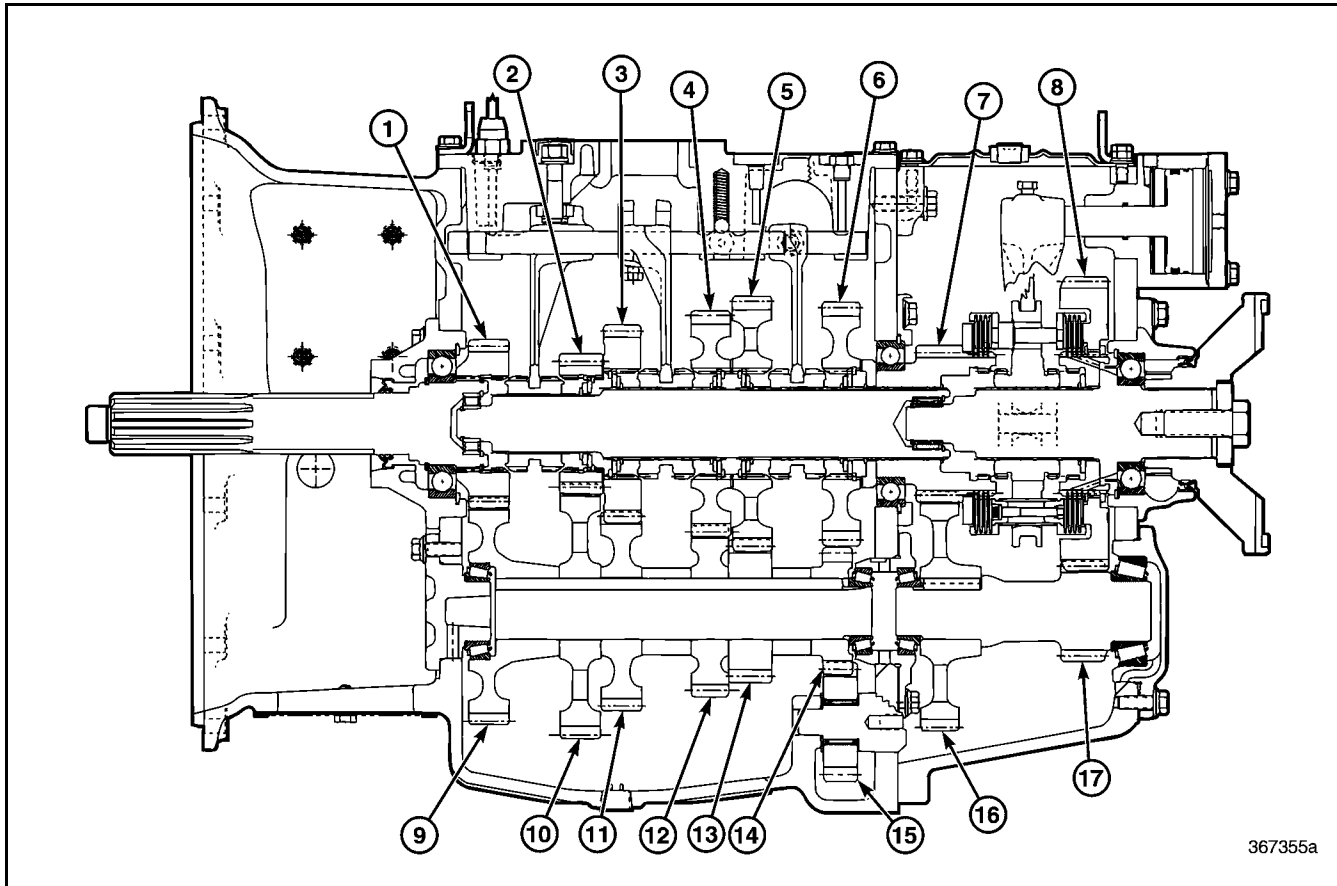

367355a

Figure 446 — T310 Gear Identification



SPECIFICATIONS

Mainshaft Gear (Main Box)	Number of Teeth	Outside Diameter
1. Main Drive Pinion (4th/9th)	33	5.635
2. 5th/10th Speed	27	4.694
3. 3rd/8th Speed	39	6.605
4. 2nd/7th Speed	45	7.541
5. 1st/6th Speed	45	8.500
6. Reverse	42	8.129
Mainshaft Gear (Compound)		
7. Main Drive Gear (Hi-Range)	30	5.204
8. Lo-Range Gear	57	9.816
Countershaft Gear (Main Box)		
9. Main Drive Gear	47	7.585
10. 5th/10th Speed (PTO) Gear	53	8.517
11. 3rd/8th Speed	40	6.643
12. 2nd/7th Speed	33	5.757
13. 1st/6th Speed	24	4.789
14. Reverse	21	3.983
15. Reverse Idler	19	
Countershaft Gear (Compound)		
16. Main Drive Gear	49	8.001
17. Lo-Range Gear (Part of Shaft)	18	3.351



SPECIFICATIONS

Fits and Limits

ALL FORKS AND SLIDING CLUTCHES

	Minimum New	Maximum New	Maximum Wear
1. Clearance between fork pad and clutch groove	0.005 inch	0.020 inch	0.050* inch
2. Clearance between synchronizer shift fork pads and sliding clutch	0.073 inch	0.087 inch	0.135 inch

*If unit has experienced disengagement, clearance must not exceed 0.030-inch maximum.

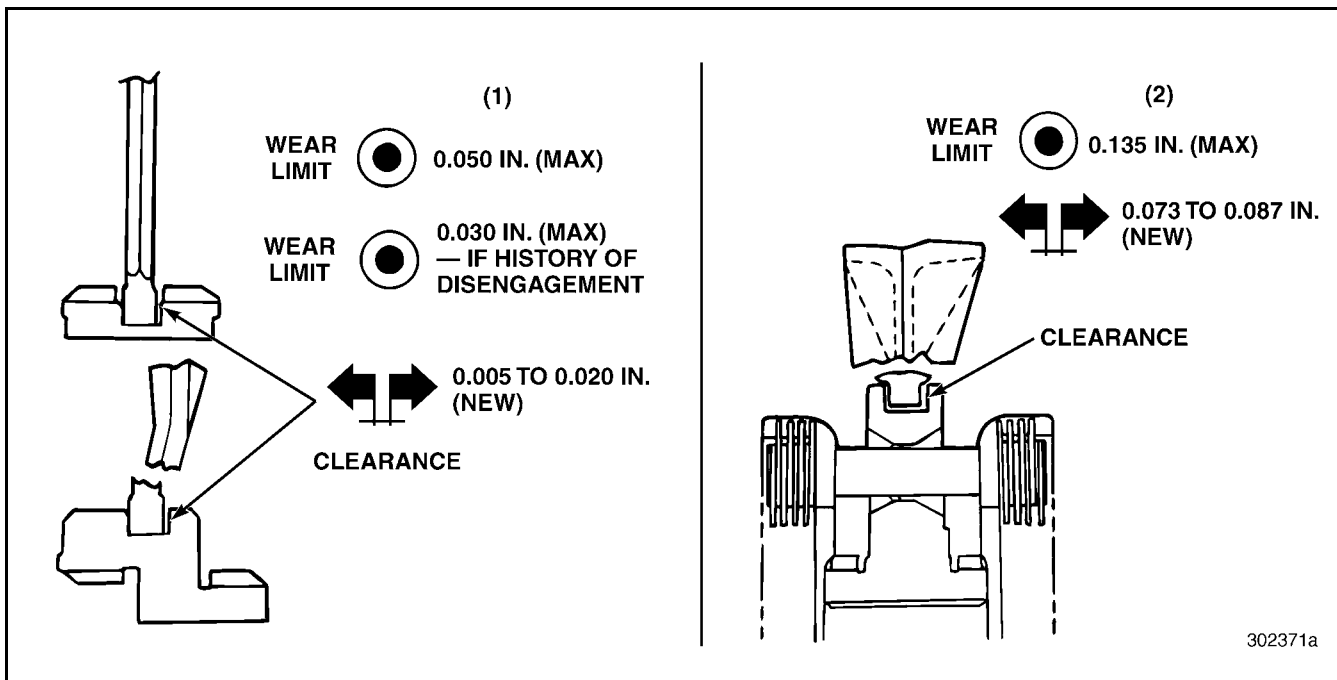

Figure 447 — Sliding Clutch Clearances

SHIFTER AND POPPET BALL SPRING SPECIFICATIONS

Springs	Free Length	Load	Length Under Load
First (Lo)/Reverse Shifter Ball Spring	1.562 inches	41.8 ± 5 lbs.	0.875 inch
First (Lo)/Reverse Shifter Plunger Spring	1.500 inches	22.0 ± 2 lbs.	0.625 inch
Shift Rail Poppet Ball Springs (3)	2.250 inches	25 ± 2.5 lbs.	1.539 inches
Range Shift Interlock Pin Spring	1.310 inches	18.7 lbs. 31.2 lbs.	1.120 inches 1.000 inches



SPECIFICATIONS

General Tolerances

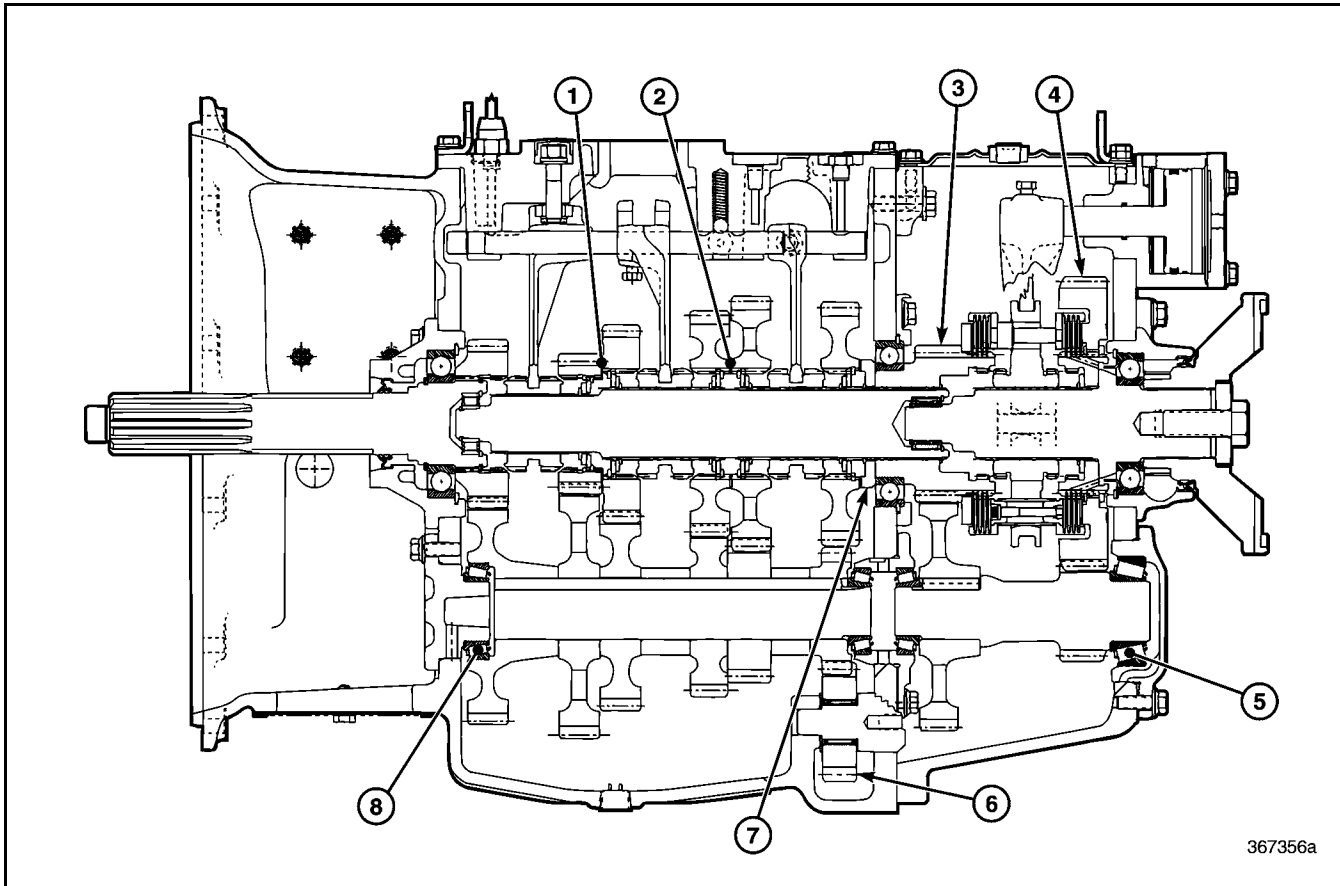

Figure 448 — Gear End Play and Bearing Preload

Component	Specification
1. Mainshaft 3rd/8th to 5th/10th Speed Gear (Floating Gear) End Play	0.024–0.081 inch
2. Mainshaft 1st/6th to 2nd/7th Speed Gear (Floating Gear) End Play	0.020–0.080 inch
3. Compound Main Drive Gear End Play	0.006–0.040 inch
4. Rear Mainshaft Lo-Range Gear End Play	0.002–0.026 inch
5. Rear Countershaft Bearing Preload	0.002–0.006 inch
6. Reverse Idler Gear End Play	0.010–0.090 inch (shaft flush with case wall)
7. Reverse Gear to Spacer	0.003–0.050 inch (shaft seated)
8. Front Countershaft Bearing Preload	0.003–0.007 inch
— Shift Rails-to-Mating Bore Clearance	0.010-inch maximum



SPECIFICATIONS

Transmission Specifications and Capacities

Make	Mack Trucks, Inc.
Type	Overdrive, Triple Countershaft
Controls	Selective, One Lever Manual with Air-Shifted Rear Compound
Speeds	Ten Forward, Two Reverse
Bell Housing	SAE No. 1, Integral with Main Case
Cases	Cast Aluminum, Heat Treated
Gears	Spur Type
Shaft Splines	Fine Pitch, Rolled Involute
Lubrication	Splash Lubrication
Oil Filter	Integral, Magnetic
Drain Plug	Magnetic
PTO Openings:	
Left Side	Std. SAE 8-Hole (Main Case)
Right Side	Std. SAE 6-Hole (Main Case)
Oil Capacity	Approx. 24 pints (depends on angle of installation in chassis)

Recommended SAE Grade Gear Oil for all temperature operations, MACK GO-J and GO-J Plus* or TO-A* Specification:

- SAE 90, 140, 80W-90, 80W-140, 85W-140 for Mineral Base
- SAE 50, 75W-90, 75W-140, 80W-140 for Synthetic Base

*GO-J Plus or TO-A Plus is required for MACK-g geared component extended service drain intervals.

Visit Mack Trucks, Inc. internet web site at www.macktrucks.com for MACK-approved oil suppliers.



SCHEMATIC & ROUTING DIAGRAMS

SCHEMATIC & ROUTING DIAGRAMS



SCHEMATIC & ROUTING DIAGRAMS

SCHEMATIC DIAGRAMS [543]

Air Piping Diagram

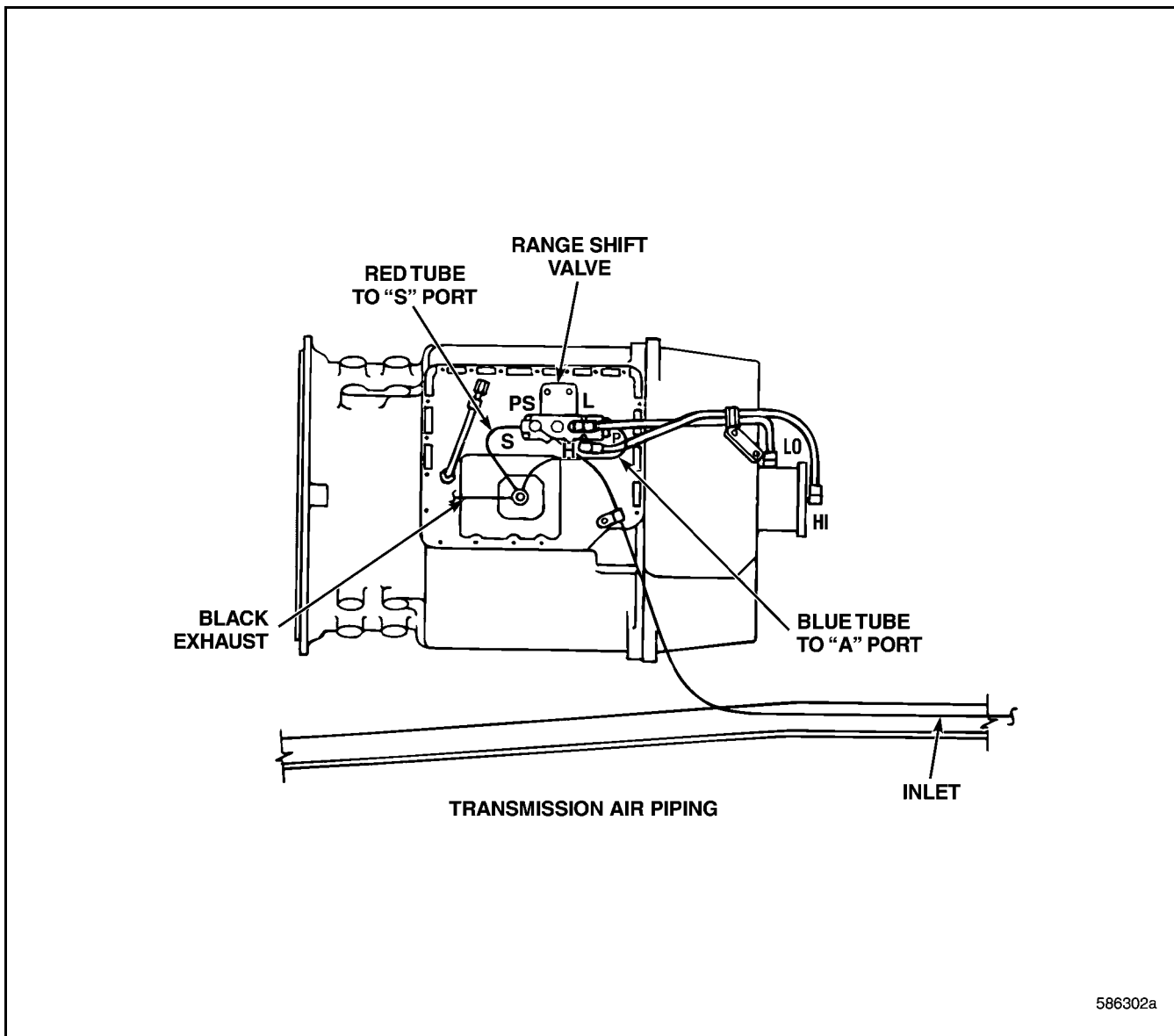

Figure 449 — Air Piping Diagram



SCHEMATIC & ROUTING DIAGRAMS

Air Control Schematic

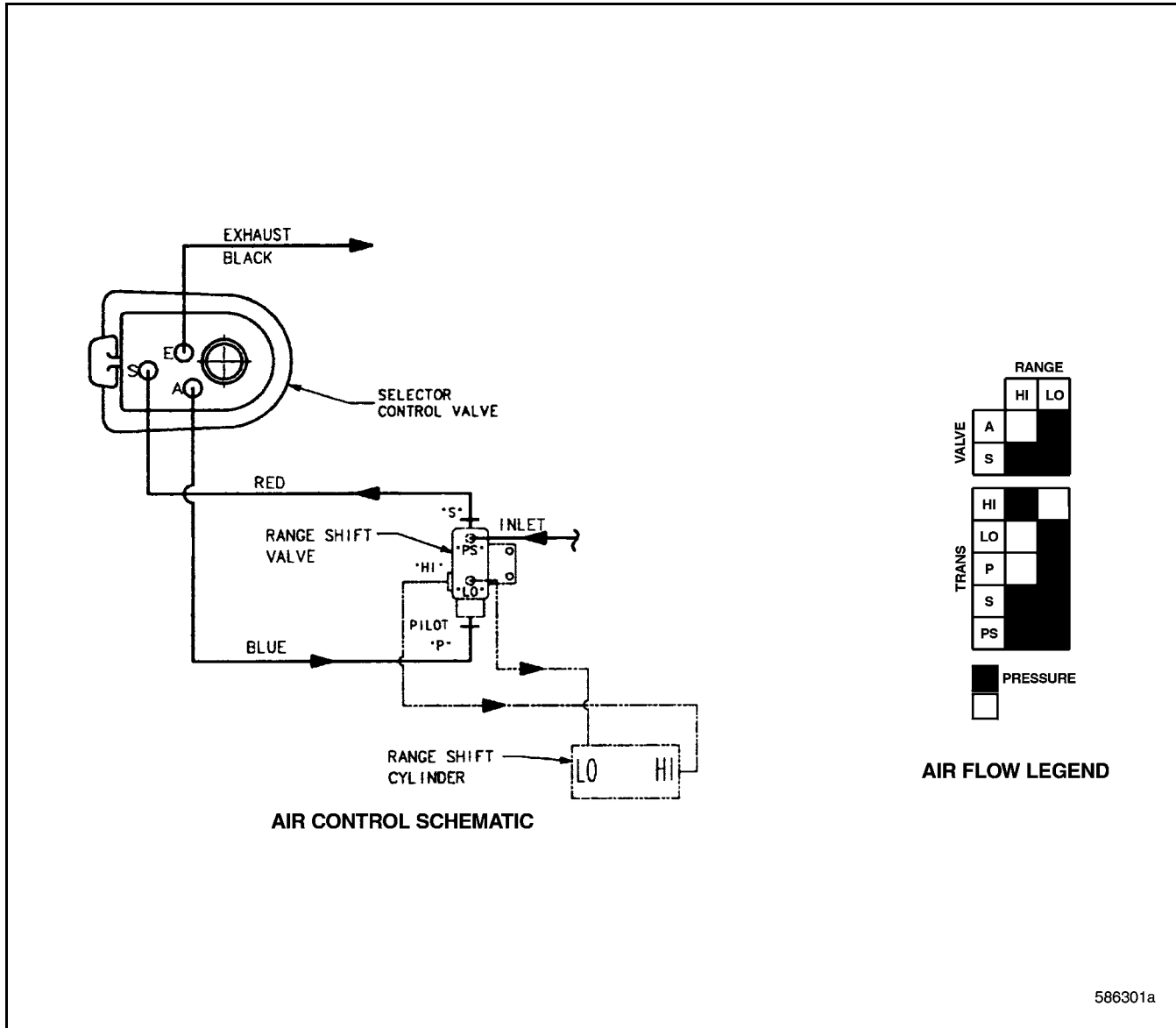

Figure 450 — Air Control Schematic



NOTES



SPECIAL TOOLS & EQUIPMENT

SPECIAL TOOLS & EQUIPMENT



SPECIAL TOOLS & EQUIPMENT

SPECIAL TOOLS AND EQUIPMENT

Special Tools

TOOLS

J 21834-4A	Two Jaw Adjustable Puller
J 22912-01	Bearing Separator
J 23775-01	100–600 lb-ft Torque Wrench
J 24407	30–250 lb-ft Torque Wrench
J 02619-A	Slide Hammer
J 29048	Tapered Feeler Gauge
J 29369-1	Bearing Puller
J 29369-2	Bearing Puller
J 34629	Snap Ring Pliers Set
J 34630	Reverse Idler Shaft Removal Tool
J 36052	Positioning Tool
J 36053	Seal Driver
J 39854	Seal Driver
J 39477	Bar Type Puller
J 05959-A	Dial Indicator Set
J 8092	Driver Handle
J 8176	Bearing Separator
OEM-4052	Internal Puller
J 07804-A	Yoke and Flange Remover
9032-1800trk	Air Line Quick Disconnect Fitting Tool Kit Available through MACK Parts System

Above tools are available from Kent-Moore
(except as noted):

KENT-MOORE

O.E. TOOL AND EQUIPMENT GROUP

SPX CORPORATION

28635 MOUND ROAD

WARREN, MICHIGAN 48092-3499

TEL: 1-800-328-6657

FAX: 1-800-578-7375



DISASSEMBLED VIEWS

DISASSEMBLED VIEWS



DISASSEMBLED VIEWS

DISASSEMBLED VIEWS

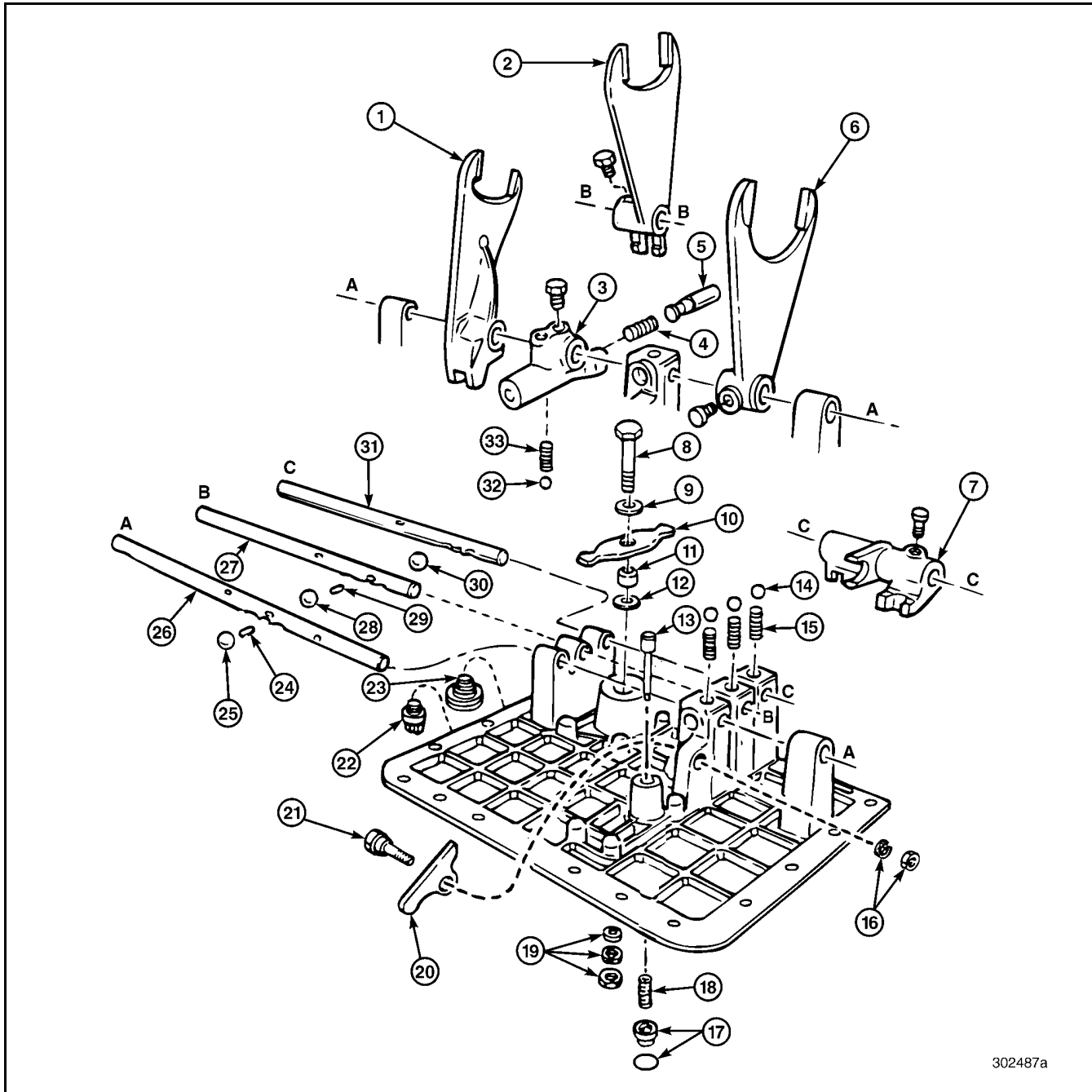

302487a

Figure 451 — Exploded View of Main Case Shift Cover

1. 4th/5th Shift Fork	12. Washer	23. Breather
2. 2nd/3rd Shift Fork	13. Interlock Pin	24. Interlock Pin
3. 1st/Reverse Shifter	14. Poppet Ball	25. Interlock Ball
4. Shifter Body Spring (Interlock)	15. Poppet Ball Spring	26. 1st/Reverse Shift Rail
5. Shifter Body Plunger (Interlock)	16. Interlock Rocker Hardware	27. 2nd/3rd Shift Rail
6. 1st/Reverse Shift Fork	17. Interlock Sleeve and O-Ring	28. Interlock Ball
7. 4th/5th Shifter	18. Interlock Spring	29. Interlock Pin
8. 4th/5th Rocker Pin	19. 4th/5th Rocker Pin Hardware	30. Interlock Ball
9. Washer	20. Interlock Rocker	31. 4th/5th Shift Rail
10. 4th/5th Rocker Arm	21. Interlock Rocker Bolt	32. 1st/Reverse Shifter Ball
11. Bushing	22. Pipe Plug	33. 1st/Reverse Shifter Spring



DISASSEMBLED VIEWS

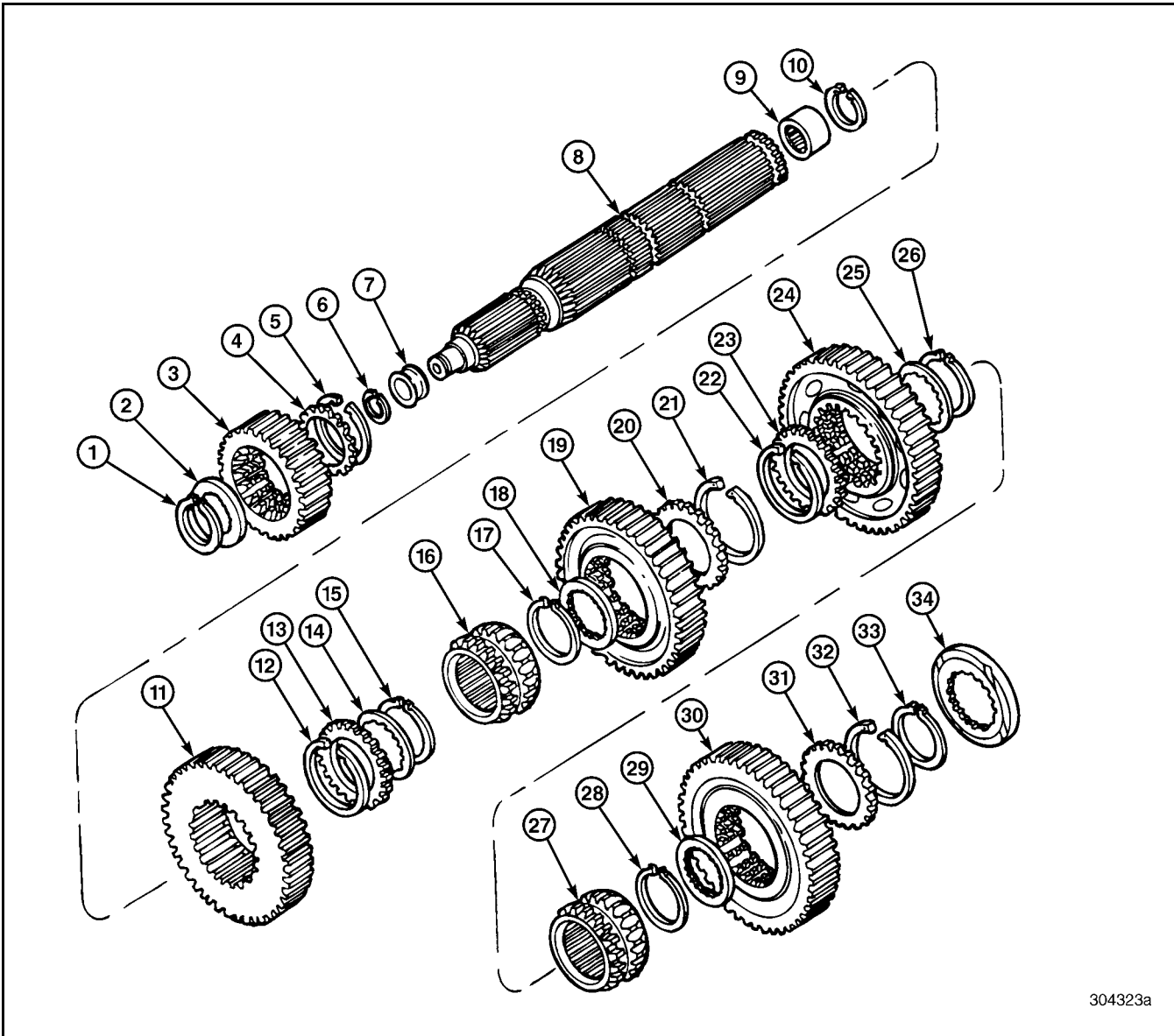

304323a

Figure 452 — Exploded View of Front Mainshaft

1. Mainshaft Snap Ring	12. Gear Snap Ring	24. First (6th) Speed Gear
2. Internal-Toothed Thrust Washer	13. External-Toothed Thrust Washer	25. Internal-Toothed Thrust Washer
3. Fifth (10th) Speed Gear	14. Internal-Toothed Thrust Washer	26. Mainshaft Snap Ring
4. External-Toothed Thrust Washer	15. Mainshaft Snap Ring	27. Sliding Clutch
5. Gear Snap Ring	16. Sliding Clutch	28. Mainshaft Snap Ring
6. Spigot-Bearing Inner Race Snap Ring	17. Mainshaft Snap Ring	29. Internal-Toothed Thrust Washer
7. Spigot-Bearing Inner Race	18. Internal-Toothed Thrust Washer	30. Reverse Speed Gear
8. Front Mainshaft	19. Second (7th) Speed Gear	31. External-Toothed Thrust Washer
9. Spigot Bearing	20. External-Toothed Thrust Washer	32. Gear Snap Ring
10. Spigot Bearing Snap Ring	21. Gear Snap Ring	33. Mainshaft Snap Ring
11. Third (8th) Speed Gear	22. Gear Snap Ring	34. Spacer
	23. External-Toothed Thrust Washer	



DISASSEMBLED VIEWS

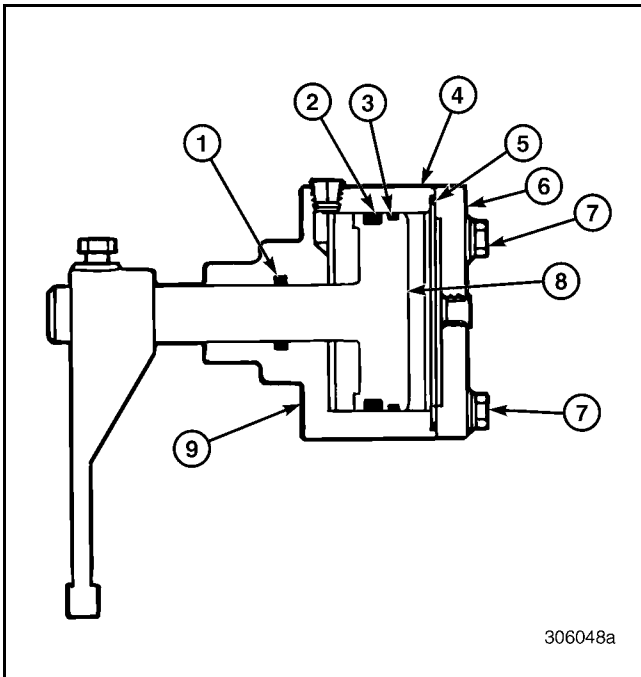

Figure 453 — Cutaway View of Range Shift Cylinder

- | | |
|------------------------------|-------------------------------|
| 1. Shift Rail Seal | 6. Cylinder Housing Cover |
| 2. Piston Seal | 7. Cover Capscrew |
| 3. Shift Cylinder Wiper Ring | 8. Piston/Shift Rail Assembly |
| 4. Shift Cylinder Housing | 9. Gasket |
| 5. Housing-to-Cover O-Ring | |

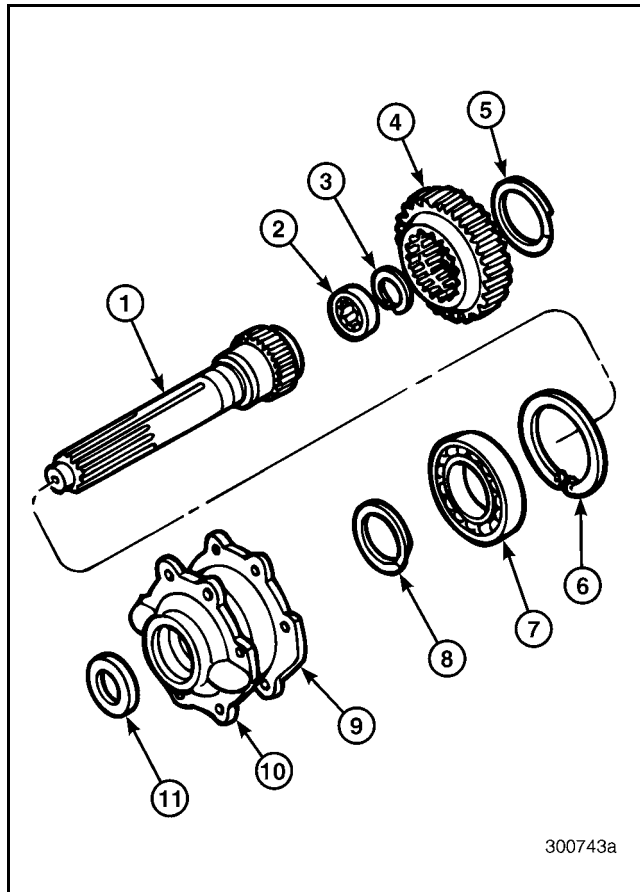

Figure 455 — Exploded View of Main Drive Pinion

- | | |
|----------------------------|--------------------------|
| 1. Main Drive Pinion Shaft | 7. Bearing |
| 2. Spigot Bearing | 8. Spiral Snap Ring |
| 3. Snap Ring | 9. Gasket |
| 4. Main Drive Pinion Gear | 10. Pinion Bearing Cover |
| 5. Spiral Snap Ring | 11. Oil Seal |
| 6. Snap Ring | |

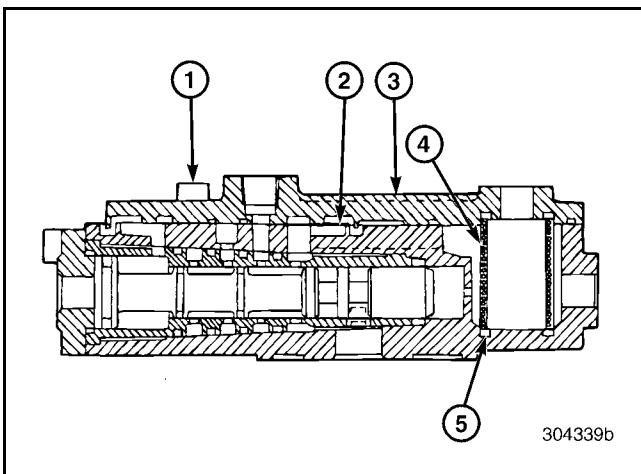

Figure 454 — Cutaway View of Range Shift Interlock Valve Assembly

- | | |
|-------------------|---------------------------|
| 1. 4 mm Screw | 4. Sintered Bronze Filter |
| 2. Top Cover Seal | 5. Silicon Rubber O-Ring |
| 3. Top Cover | |



DISASSEMBLED VIEWS

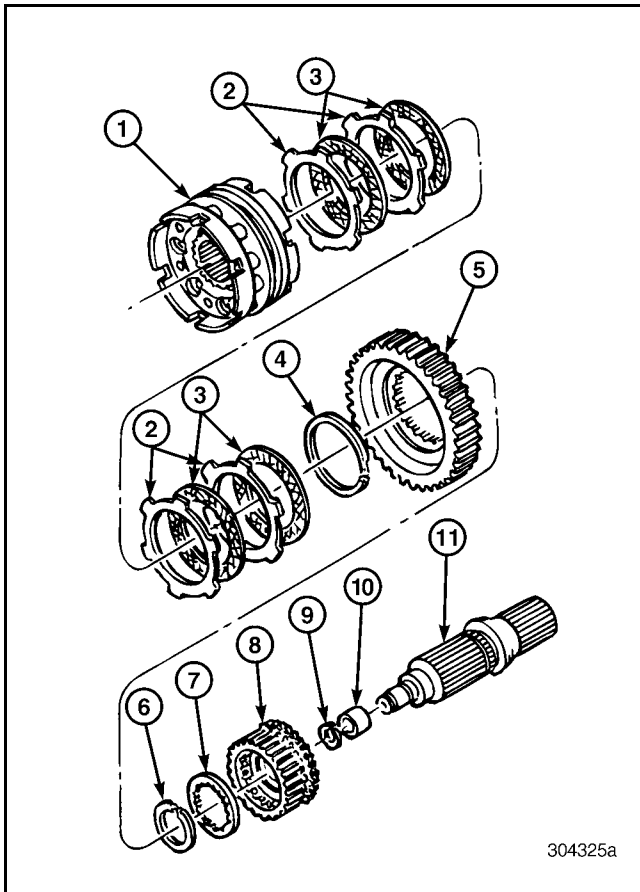

Figure 456 — Exploded View of Rear Mainshaft and Synchronizer Assembly

1. Synchronizer Assembly	7. Internal-Toothed Thrust Washer
2. Reaction Discs	8. Lo-Range Gear Hub
3. Friction Discs	9. Snap Ring
4. Snap Ring	10. Spigot Bearing Inner Race
5. Lo-Range Gear	11. Rear Mainshaft
6. Snap Ring	

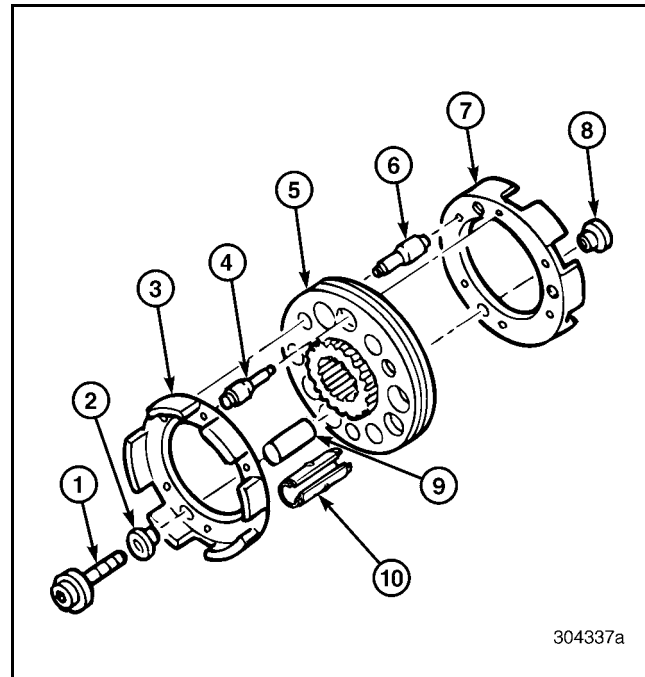

Figure 457 — Exploded View of Synchronizer

1. 12-Point Screw	6. Synchronizer Pin
2. Nonthreaded Insert	7. Clutch Housing
3. Clutch Housing	8. Threaded Insert
4. Synchronizer Pin	9. Support Tube
5. Sliding Clutch	10. Preload Spring

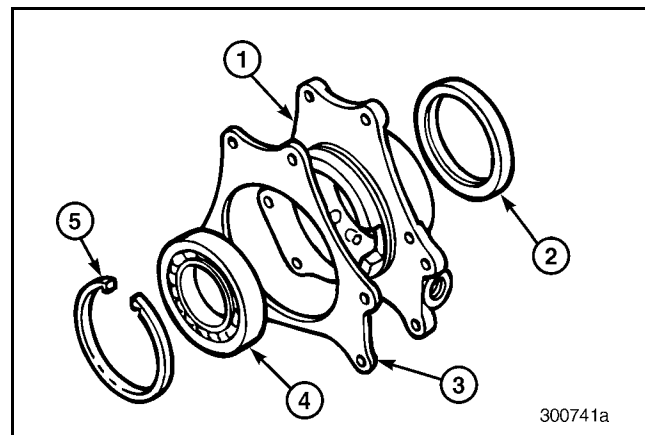
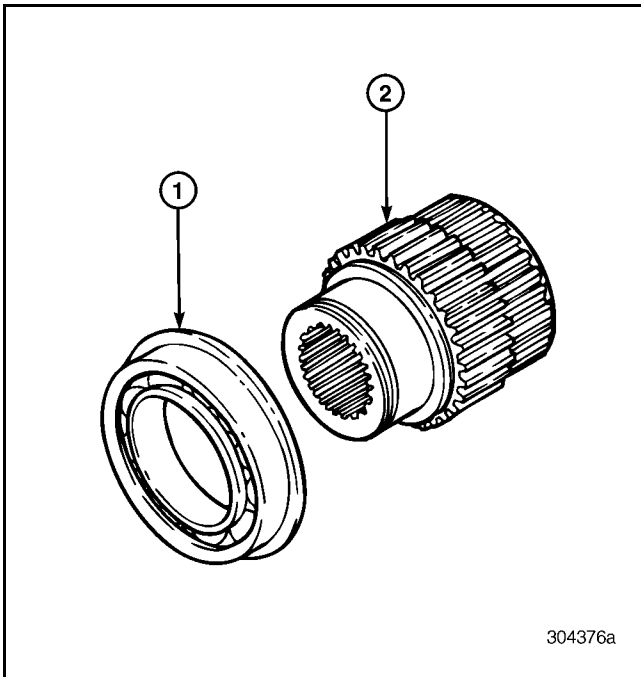

Figure 458 — Exploded View of Rear Mainshaft Bearing Cover

1. Bearing Cover	4. Bearing
2. Oil Seal	5. Snap Ring
3. Gasket	



DISASSEMBLED VIEWS



304376a

Figure 459 — Exploded View of Rear Compound Main Drive Gear

- | | |
|--------------------------|--------------------|
| 1. Bearing and Snap Ring | 2. Main Drive Gear |
|--------------------------|--------------------|

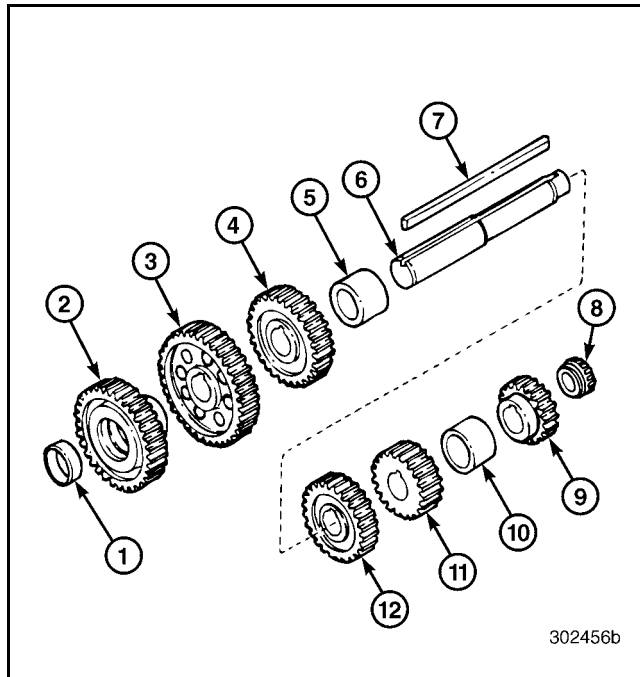

302456b

Figure 461 — Exploded View of Front Countershaft

- | | |
|----------------------------|-----------------------------|
| 1. Bearing Cup | 8. Bearing Cone |
| 2. Main Drive Gear | 9. Reverse Speed Gear |
| 3. Fifth (10th) Speed Gear | 10. Spacer — Rear |
| 4. Third (8th) Speed Gear | 11. First (6th) Speed Gear |
| 5. Spacer — Front | 12. Second (7th) Speed Gear |
| 6. Front Countershaft | |
| 7. Key | |

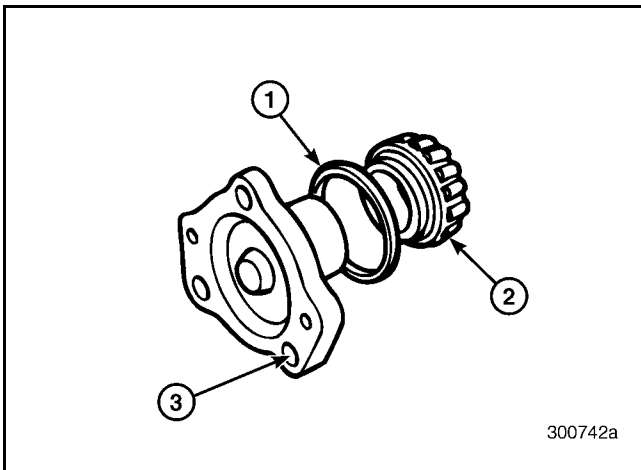

300742a

Figure 460 — Exploded View of Front Countershaft Front Bearing Cover

- | | |
|-----------------|------------------------|
| 1. O-Ring | 3. Front Bearing Cover |
| 2. Bearing Cone | |

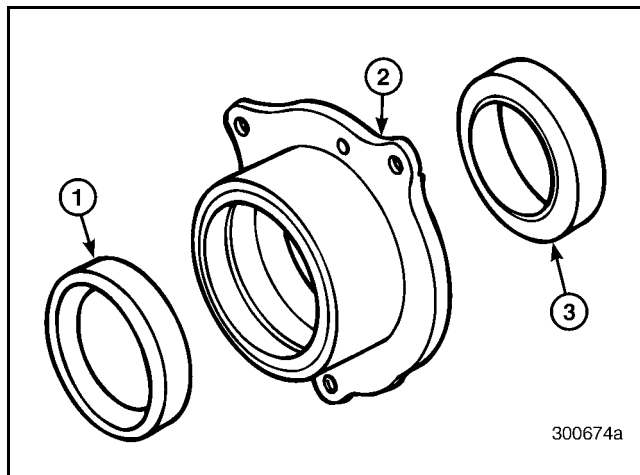

300674a

Figure 462 — Exploded View of Front Countershaft Rear Bearing Cover

- | | |
|----------------------|---------------------|
| 1. Front Bearing Cup | 3. Rear Bearing Cup |
| 2. Bearing Cover | |



DISASSEMBLED VIEWS

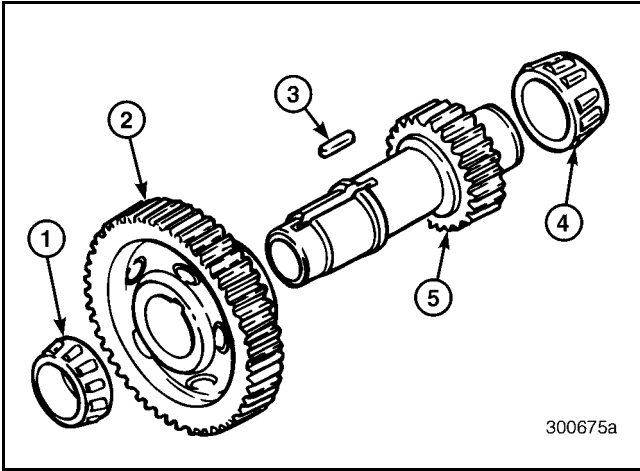

Figure 463 — Exploded View of Rear Countershaft

1. Front Bearing Cone	4. Rear Bearing Cone
2. Main Drive Gear	5. Rear Countershaft
3. Key	

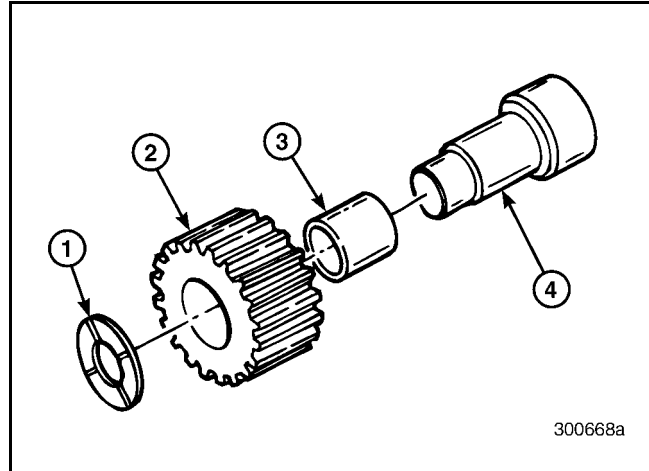

Figure 465 — Exploded View of Reverse Idler Gear Assembly

1. Thrust Washer	3. Bearing
2. Reverse Idler Gear	4. Reverse Idler Shaft

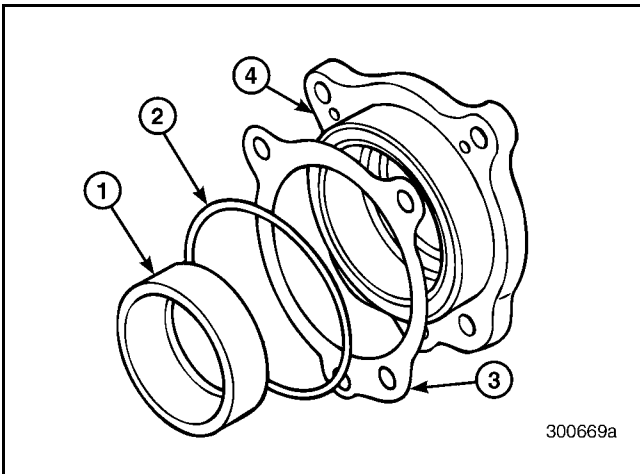

Figure 464 — Exploded View of Rear Countershaft Bearing Cover

1. Bearing Cup	3. Shim(s)
2. O-Ring	4. Bearing Cover



NOTES



INDEX

INDEX



INDEX

A	G
ADVISORY LABELS2	GEAR IDENTIFICATION 172
AIR BREATHER30	GEAR RATIOS AND SHIFT PATTERN 16
AIR CONTROL SCHEMATIC179	GEARS [322] 94
AIR PIPING DIAGRAM178	GENERAL INSPECTION 96
	GENERAL REASSEMBLY
	INSTRUCTIONS 96
	GENERAL TOLERANCES 175
B	I
BEARINGS [322]94	INSPECTION AND CLEANING 94
	INSPECTION OF PARTS 94
C	L
CHANGE INTERVAL29	LUBRICATION 15
CHANGING OIL29	
CHECKING OIL LEVEL28	M
COMPONENT LOCATOR22	MAGNETIC OIL FILTER PLUG 30
COMPOUND MAIN DRIVE GEAR	MAIN CASE SHIFT COVER
DISASSEMBLY [322]84	DISASSEMBLY [323] 51
COMPOUND MAIN DRIVE GEAR	REASSEMBLY [323] 134
REASSEMBLY [322]106	MAIN DRIVE PINION
CONVERSION CHART6	DISASSEMBLY [322] 68
	REASSEMBLY [322] 124
D	O
DESCRIPTION AND OPERATION14	OIL FILL 29
DISASSEMBLED VIEWS184	OIL SEALS [321] 95
DRAINING OIL29	
E	P
EXPLANATION OF NUMERICAL CODE5	POWER FLOW DIAGRAMS 17
F	R
FITS AND LIMITS174	RANGE SHIFT VALVE [323] 127
FRONT COUNTERSHAFT	RANGE SHIFT VALVE [323] 66
DISASSEMBLY [322]86	REAR COUNTERSHAFT BEARING COVER
FRONT COUNTERSHAFT FRONT BEARING	DISASSEMBLY [321] 92
COVER DISASSEMBLY [321]85	REAR COUNTERSHAFT BEARING COVER
FRONT COUNTERSHAFT FRONT BEARING	REASSEMBLY [321] 98
COVER REASSEMBLY [321]105	REAR COUNTERSHAFT
FRONT COUNTERSHAFT REAR BEARING	DISASSEMBLY [322] 90
COVER DISASSEMBLY [321]89	REAR COUNTERSHAFT
FRONT COUNTERSHAFT REAR BEARING	REASSEMBLY [322] 99
COVER REASSEMBLY [321]100	REAR MAINSHAFT AND SYNCHRONIZER
FRONT COUNTERSHAFT	DISASSEMBLY [322] 78
REASSEMBLY [322]101	
FRONT MAINSHAFT	
DISASSEMBLY [322]71	
FRONT MAINSHAFT	
REASSEMBLY [322]116	



INDEX

REAR MAINSHAFT BEARING COVER DISASSEMBLY [321]	83		
REAR MAINSHAFT BEARING COVER REASSEMBLY [321]	107		
REAR MAINSHAFT REASSEMBLY [322]	112		
REVERSE IDLER GEAR DISASSEMBLY [322]	93		
REVERSE IDLER GEAR REASSEMBLY [322]	97		
S			
SAFETY INFORMATION	2		
SCHEMATIC DIAGRAMS	178		
SERVICE PROCEDURES AND TOOL USAGE	3		
SHIFTER FORKS, SLIDING CLUTCHES AND SHIFT RAILS [323]	94		
SPECIAL TOOLS	182		
SPECIAL TOOLS AND EQUIPMENT	182		
SPECIFICATIONS	170		
SYNCHRONIZER DISASSEMBLY [322]	81		
SYNCHRONIZER REASSEMBLY [322]	109		
T			
T310 SHIFTING INSTRUCTIONS	17		
T310 TRANSMISSIONS	14		
TORQUE SPECIFICATIONS	170		
TRANSMISSION COMPONENT DISASSEMBLY	51		
TRANSMISSION COMPONENT REASSEMBLY	97		
TRANSMISSION DISASSEMBLY PROCEDURES	32		
TRANSMISSION IDENTIFICATION	10		
TRANSMISSION MAINTENANCE	28		
TRANSMISSION REASSEMBLY PROCEDURES	147		
TRANSMISSION SPECIFICATIONS AND CAPACITIES	176		
TROUBLESHOOTING CHARTS	24		
TWO-POSITION RANGE SHIFT CYLINDER DISASSEMBLY [324]	65		
TWO-POSITION RANGE SHIFT CYLINDER REASSEMBLY [324]	129		
U			
UNIT IDENTIFICATION STAMPING LOCATION	10		



NOTES



PRINTED IN U.S.A.
10-126

MAXITORQUE[®]
ES

TRANSMISSION

T310

SERVICE MANUAL

© MACK TRUCKS, INC. 2003