

BROUGHT TO YOU BY PRO GEAR &
TRANSMISSION.

FOR PARTS OR SERVICE CALL:

877-776-4600

407-872-1901



WWW.PGTTRUCKPARTS.COM

906 W. GORE ST. ORLANDO, FL 32805
PARTS@EPROGEAR.COM



MERITOR™

A Heritage of Rockwell Technology

Engine Synchro Shift™ (ESS™) Transmissions

Operator Manual
TP-95130
Revised 5-98

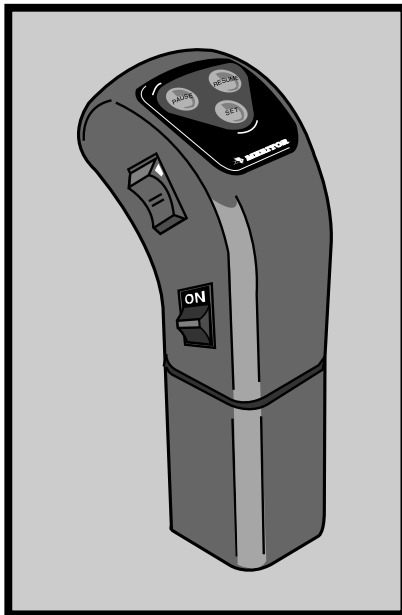

Engine Synchro Shift™ (ESS™) Transmissions

Applications

- Nine-speed RS direct drive and RSX overdrive models with **A**, **B** and **R** ratios
- Ten-speed RS direct drive and RSX overdrive models with **A** ratio

ESS™ Transmission Shift Patterns

1. RS direct drive models with **A** and **B** ratios
2. RSX overdrive models with **A** and **B** ratios
3. RSX overdrive models with **R** ratios

Identify the Transmission

Refer to the shift pattern decal affixed to the sun visor or instrument panel, or to the identification tag on the transmission before you operate the vehicle.

Understand the Vehicle's Model Number Designation

The illustration below explains how to read the transmission model number.

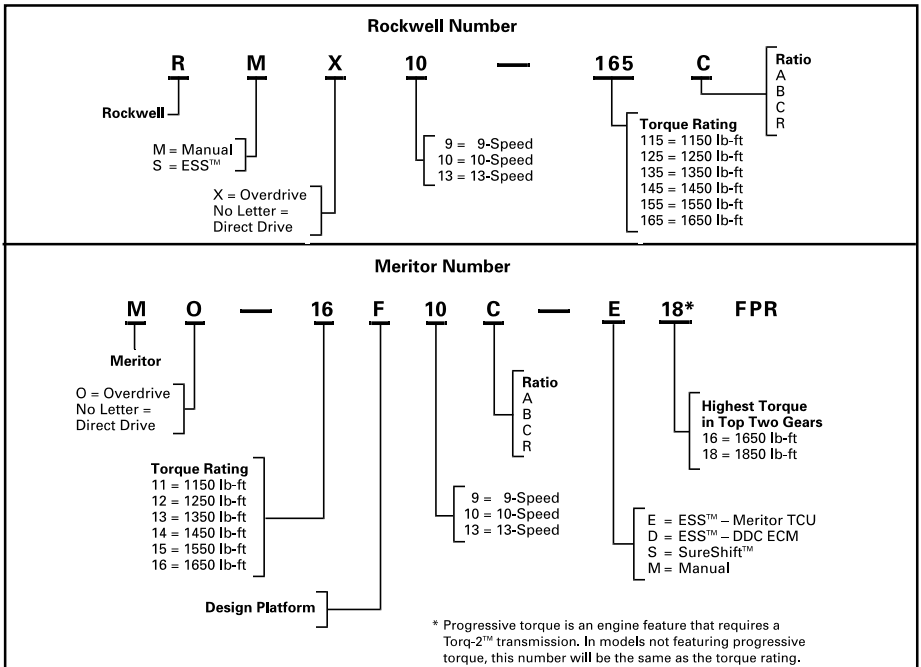

Operate the Vehicle Safely

Refer to the vehicle manufacturer's operator's guide for procedures to operate the vehicle safely.

Engine Synchro Shift™ (ESS™) System Features

Synchronizes the Transmission

- ◆ The Engine Synchro Shift™ (ESS™) system automatically synchronizes the transmission by matching engine rpm to the vehicle's road speed.

Getting Started

- ◆ With the ESS™ system, only use the clutch pedal to **START** and **STOP** the vehicle, or to shift into **FORWARD** or **REVERSE**. If you depress the clutch while driving, the ESS™ system becomes inactive, and you have manual control of the transmission.

Automated HI and LO Range

- ◆ Range shifts are automatic, which means you do not have to preselect **HI** or **LO** ranges.

Break Torque Feature

- ◆ You can move the shift lever out of gear *without* changing throttle position. The ESS™ system will automatically synch engine rpm to road speed.
- ◆ With the ESS™ system you can apply the service brake as you downshift through the gears when you are stopping the vehicle.
- ◆ On steep grades, the ESS™ system allows you to maintain throttle position *without* using the clutch.

ESS™ System Components

- ◆ System switch
- ◆ Shift Intent switch
- ◆ Speed sensors for transmission input and output shafts
- ◆ **NEUTRAL (N)** position sensor (located in the shift tower)
- ◆ Electropneumatic solenoid (located in the transmission)

How It Works

The Engine Synchro Shift™ (ESS™) system collects and relays the following information to the engine control module (ECM):

- The positions of the system switch and the shift intent switch
- The speeds of the transmission input shaft and output shaft
- The position of the shift lever in the shift tower

The ECM processes the information and relays the data to the Fuel Control System that increases or decreases engine rpm speed to match the vehicle's road speed. The ECM also controls the HI or LO range selection in the auxiliary case on the rear of the transmission.

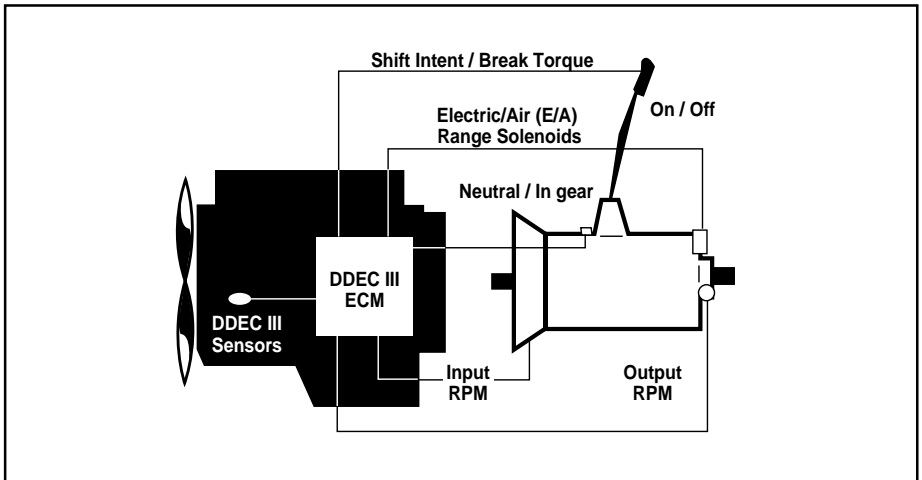

On the Shift Knob

The System Switch

The two-position **SYSTEM SWITCH**, the lowest switch on the **OPERATOR'S SIDE** of the shift knob, turns the ESS™ system **ON** and **OFF** and displays the system status.

- ◆ When you slide the system switch **DOWN**, you see the word “**ON**.” This means that the ESS™ system is activated.
- ◆ When you slide the switch **UP**, you see the word “**OFF**.” This means that the ESS™ system is not activated, and you have manual control of the transmission.

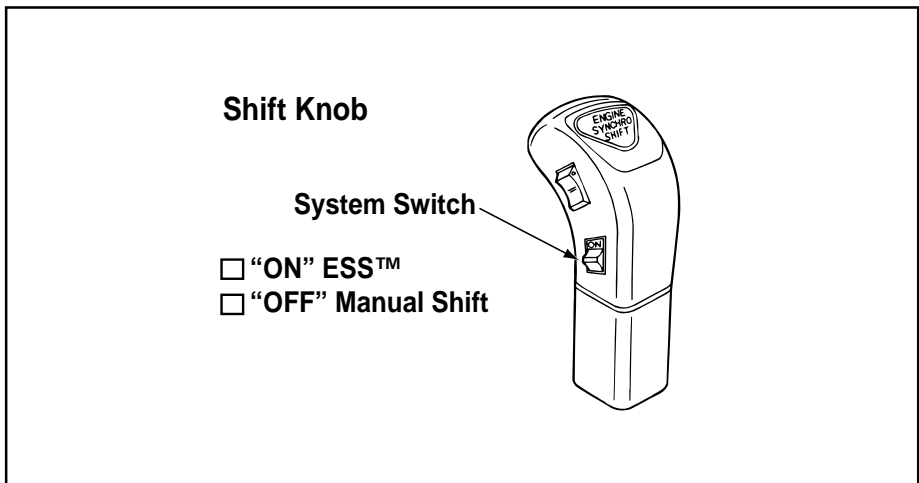

The Shift Intent Switch

- ◆ The **SHIFT INTENT SWITCH** is a four-position rocker switch located above the **SYSTEM SWITCH** on the **OPERATOR'S SIDE** of the shift knob.
- ◆ When the ESS™ system is turned **ON**, the **SHIFT INTENT SWITCH** signals the engine control module (ECM) that you will **UPSHIFT** or **DOWNSHIFT**, based on your input.
- ◆ You can also use the **SHIFT INTENT SWITCH** to release torque on the gears — **BREAK TORQUE** — just before you shift. Just press the switch all the way in to the end of its travel, and then release it without changing throttle position.

- ◆ When the ESS™ system is turned **OFF** (which means that the system is inactive), you have manual control of the transmission. The **SHIFT INTENT SWITCH** acts as a range selector.
- ◆ **To preselect range shifts:** While in gear, press the **TOP** of the **SHIFT INTENT SWITCH** for **HI** range and the **BOTTOM** of the switch for **LOW** range.

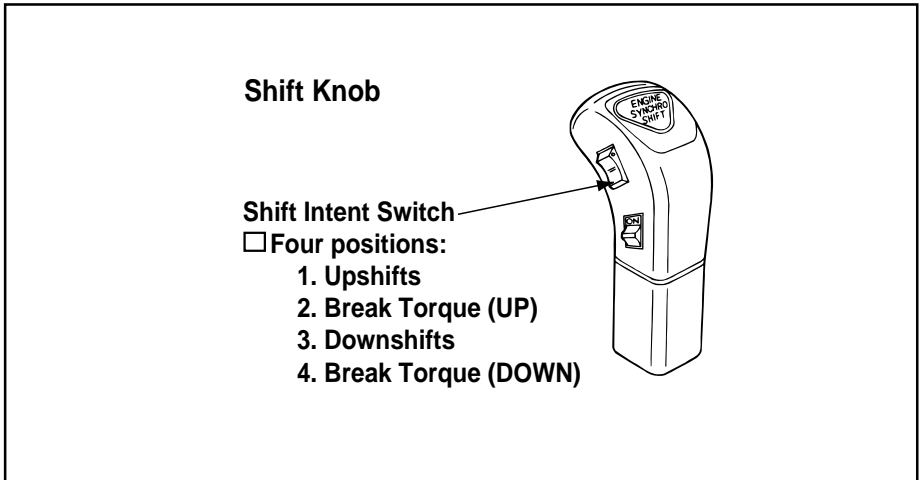

How to Shift



WARNING

The transmission must be in the NEUTRAL (N) position when you start the vehicle. If you start the vehicle with the transmission in gear, the vehicle will suddenly move FORWARD or REARWARD. Serious personal injury and damage to the transmission can result.

To Start the Vehicle

1. Check that the shift lever is in the **NEUTRAL (N)** position.
2. Push the clutch pedal to the bottom of travel to engage the clutch brake.
3. Start the engine.
4. Slowly release the clutch pedal.
5. Allow the air pressure in the air system to reach the specified range on the gauge.
6. Release the parking brakes.

Shift Into a Starting Gear

1. Turn **ON** (Activate) the ESS™ System:

- ◆ Slide the two-position **SYSTEM SWITCH** (the lowest switch on the **OPERATOR'S SIDE** of the shift knob) **DOWN**. You will see the word "**ON**," which means that the ESS™ system is activated.



CAUTION

Use the clutch brake only for initial gear engagement when the vehicle is stationary to avoid damage to the input shaft and/or the clutch brake.

2. Disengage the Clutch:

- ◆ Push the clutch pedal to the bottom of travel. (The clutch brake will touch the clutch release bearing.) Clutch disengagement stops the transmission for initial gear engagement.



CAUTION

*Always use the correct starting gear when you operate the transmission. Do not shift into **NEUTRAL** and coast. Damage to the transmission can result.*

3. Shift Into a Starting Gear:

- ◆ With the clutch pedal at the bottom of travel, move the shift lever into a starting gear.
- ◆ Slowly release the clutch pedal to move the vehicle **FORWARD**.

ESS™ System Safety Feature: The "Time-Out Sequence"

The ESS™ system has a built-in safety feature called the "**TIME-OUT SEQUENCE**." If you do not complete a shift from **NEUTRAL (N)** within two seconds after you break torque, the system becomes inactive — or "times-out" — and returns the transmission to manual control.

To turn ON (reactivate) the ESS™ system so that you can continue to shift:

- ◆ Press the **SHIFT INTENT SWITCH** again. (Refer to the "Upshifting" and "Downshifting" sections in this manual for instructions on how to use the **SHIFT INTENT SWITCH**.)

Upshifting Into the Next Higher Gear

NOTE

Expect a DROP in rpm when you UPSHIFT.

1. Press the **TOP** of the **SHIFT INTENT SWITCH** **once** for first shift. This signals the ESS™ system that you will **UPSHIFT**. Then move **UP** through the gears without pressing the switch again. **Figure A.**
2. To break engine torque, continue to press the **TOP** of the **SHIFT INTENT SWITCH** all the way in to the end of its travel and then release it, which enables the shift lever to move freely out of gear. **Figure B.**

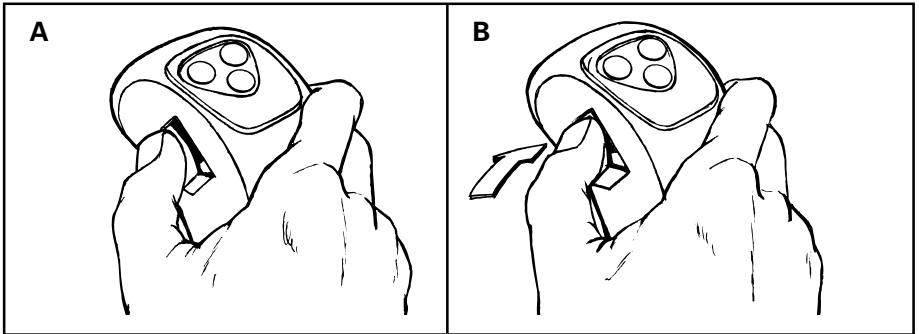

NOTE

When you shift, do not rush or try to “beat” the system. If you experience “gear clashing,” you have shifted too fast. Just shift at a natural pace or speed.

3. **Immediately** move the shift lever into **NEUTRAL (N)** and pause for a second. The ESS™ system will slow down the engine to the correct rpm and synchronize the transmission to road speed.
4. Move the shift lever into the next **HIGHER** gear.

Upshifting Into the Rest of the Gears

1. Press the **TOP** of the **SHIFT INTENT SWITCH** all the way in to the end of its travel and then release it each time you move the shift lever. The range shift is automatic.
2. Repeat steps 1 through 4.

If a Gear “Partially Engages”

1. Press the **SHIFT INTENT SWITCH** all the way in to the end of its travel and then release it.
2. Move the shift lever into the next **HIGHER** gear.

To “Skip Shift”

NOTE

“Skip shifting” causes a change in engine speed. Pause longer in NEUTRAL (N).

1. Pause longer in NEUTRAL (N) to let the ESS™ system synchronize the transmission.
2. Press the **SHIFT INTENT SWITCH** **once** for each gear you want to skip.

Downshifting Into the Next Lower Gear

NOTE

Expect a RISE in rpm when you DOWNSHIFT.

1. Press the **BOTTOM** of the **SHIFT INTENT SWITCH** **once** for first shift. This signals the ESS™ system that you will **DOWNSHIFT**. Then move **DOWN** through the gears without pressing the switch again. **Figure C.**
2. To break engine torque, continue to press the **BOTTOM** of the **SHIFT INTENT SWITCH** all the way in to the end of its travel and then release it, which enables the shift lever to move freely out of gear. **Figure D.**

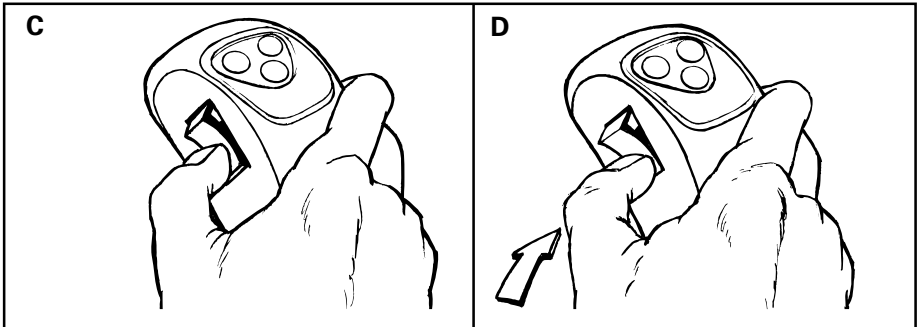

NOTE

When you shift, don't rush or try to “beat” the system. If you experience “gear clashing,” you have shifted too fast. Just shift at a natural pace or speed.

3. **Immediately** move the shift lever into NEUTRAL (N) and pause for a second. The ESS™ system will slow down the engine to the correct rpm and synchronize the transmission to road speed.
4. Move the shift lever into the next **LOWER** gear.

Downshifting Into the Rest of the Gears

1. Press the **BOTTOM** of the **SHIFT INTENT SWITCH** all the way in to the end of its travel and then release it each time you move the shift lever. The range shift is automatic.
2. Repeat steps 1 through 4.

If a Gear “Partially Engages”

1. Press the **SHIFT INTENT SWITCH** all the way in to the end of its travel and then release it.
2. Move the shift lever into the next **LOWER** gear.

To “Skip Shift”

NOTE

“Skip shifting” causes a change in engine speed. Pause longer in NEUTRAL (N).

1. Pause longer in **NEUTRAL (N)** to let the ESS™ system synchronize the transmission.
2. Press the **SHIFT INTENT SWITCH** **once** for each gear you want to skip.

Shifting Into REVERSE (R)

1. Turn **ON** (Activate) the ESS™ System:
 - ◆ Slide the two-position **SYSTEM SWITCH** (the lowest switch on the **OPERATOR’S SIDE** of the shift knob) **DOWN**. You will see the word “**ON**,” which means that the ESS™ system is activated.



CAUTION

Use the clutch brake only for initial gear engagement when the vehicle is stationary to avoid damage to the input shaft and/or the clutch brake.

2. Disengage the Clutch:
 - ◆ Push the clutch pedal to the bottom of travel. (The clutch brake will touch the clutch release bearing.) Clutch disengagement stops the transmission for initial gear engagement.
3. Shift into **REVERSE (R)**:
 - ◆ With the clutch pedal at the bottom of travel, move the shift lever into **REVERSE (R)**.
 - ◆ Slowly release the clutch pedal to move the vehicle in the reverse direction.

Shifting Into HI REVERSE Range

1. Turn **OFF** (Deactivate) the ESS™ System:
 - ◆ Slide the two-position **SYSTEM SWITCH** (the lowest switch on the **OPERATOR'S SIDE** of the shift knob) **UP**. You will see the word "**OFF**," which means that the ESS™ system is turned **OFF**, or deactivated.
2. Preselect **HI** Range:
 - ◆ With the shift lever in gear, press the **TOP** of the **SHIFT INTENT SWITCH** to put the transmission into **HI** range.



CAUTION

Use the clutch brake only for initial gear engagement when the vehicle is stationary to avoid damage to the input shaft and/or the clutch brake.

3. Disengage the Clutch:
 - ◆ Push the clutch pedal to the bottom of travel. (The clutch brake will touch the clutch release bearing.) Clutch disengagement stops the transmission for initial gear engagement.
4. Shift into **REVERSE (R)**:
 - ◆ With the clutch pedal at the bottom of travel, move the shift lever into **REVERSE (R)**.
 - ◆ Slowly release the clutch pedal to move the vehicle in the reverse direction.

ESS™ Cab Shift Labels



CAUTION

Shift patterns vary by vehicle. You must use the correct shift pattern for the vehicle you operate to avoid damage to the transmission.

1. Refer to the **SHIFT PATTERN DECAL** affixed to the sun visor or instrument panel when you shift the transmission.
2. If the decal is missing or unreadable, call Meritor's Florence Distribution Center at 888-725-9355/Option #5 to order a new decal.
3. Install the new decal in the vehicle.

9-Speed RS and RSX Models



ENGINE SYNCHRO SHIFT

Standard

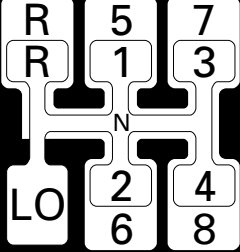

9-Speed
Transmission

TO ACTIVATE ESS:

- Turn system switch to **ON**
- Depress clutch pedal
- Select starting gear

TO UP-SHIFT:

- Fully depress shift intent switch **UP** and release
- Immediately move lever to **NEUTRAL**
- Let engine synchronize
- Move lever into higher gear 1-2-3-4-5-6-7-8

TO DOWN-SHIFT:

- Fully depress shift intent switch **DOWN** and release
- Immediately move lever to **NEUTRAL**
- Let engine synchronize
- Move lever into lower gear 7-6-5-4-3-2-1-LO

CLUTCH USE:

- Use clutch only for starting and stopping
- Depressing clutch disables engine synchronization
- System **OFF** requires use of clutch for shifting

SHIFT INTENT SWITCH

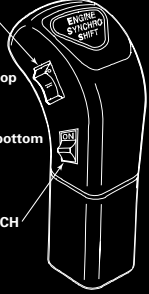

- **UPSHIFT**
– Fully depress top
- **DOWNSHIFT**
– Fully depress bottom

SYSTEM SWITCH

NOTE: System switch **OFF** activates manual control.

- Preselect shift intent switch **DOWN** for low range.
- Preselect shift intent switch **UP** for hi range.
- Do not select range in **NEUTRAL**. Preselect in gear.
- Do not range shift while moving in **REVERSE**.

Refer to TP-95130 for more information

2297-A-7125



ENGINE SYNCHRO SHIFT

Standard

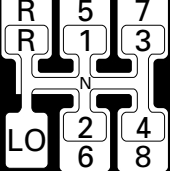

9-Speed
Transmission

TO ACTIVATE ESS:

- Turn system switch to **ON**
- Depress clutch pedal
- Select starting gear

TO UP-SHIFT:

- Fully depress shift intent switch **UP** and release
- Immediately move lever to **NEUTRAL**
- Let engine synchronize
- Move lever into higher gear 1-2-3-4-5-6-7-8

TO DOWN-SHIFT:

- Fully depress shift intent switch **DOWN** and release
- Immediately move lever to **NEUTRAL**
- Let engine synchronize
- Move lever into lower gear 7-6-5-4-3-2-1-LO

CLUTCH USE:

- Use clutch only for starting and stopping
- Depressing clutch disables engine synchronization
- System **OFF** requires use of clutch for shifting

NOTE: System switch **OFF** activates manual control.

- Preselect shift intent switch **DOWN** for low range.
- Preselect shift intent switch **UP** for hi range.
- Do not select range in **NEUTRAL**. Preselect in gear.
- Do not range shift while moving in **REVERSE**.

SHIFT INTENT SWITCH



- **UPSHIFT**
– Fully depress top
- **DOWNSHIFT**
– Fully depress bottom

SYSTEM SWITCH

NOTE: System switch **OFF** activates manual control.

- Preselect shift intent switch **DOWN** for low range.
- Preselect shift intent switch **UP** for hi range.
- Do not select range in **NEUTRAL**. Preselect in gear.
- Do not range shift while moving in **REVERSE**.

Refer to TP-95130 for more information

2297-D-7245

9-Speed R-Ratio Models



R-Ratio

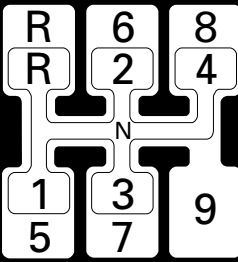

9-Speed Transmission

ENGINE SYNCHRO SHIFT

TO ACTIVATE ESS:

- Turn system switch to **ON**
- Depress clutch pedal
- Select starting gear

TO UP-SHIFT:

- Fully depress shift intent switch **UP** and release
- Immediately move lever to **NEUTRAL**
- Let engine synchronize
- Move lever into higher gear 2-3-4-5-6-7-8-9

TO DOWN-SHIFT:

- Fully depress shift intent switch **DOWN** and release
- Immediately move lever to **NEUTRAL**
- Let engine synchronize
- Move lever into lower gear 8-7-6-5-4-3-2-1

CLUTCH USE:

- Use clutch only for starting and stopping
- Depressing clutch disables engine synchronization
- System **OFF** requires use of clutch for shifting

SHIFT INTENT SWITCH

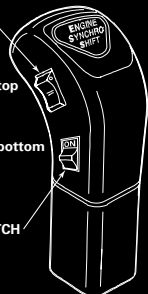

- **UPSHIFT**
– Fully depress top
- **DOWNSHIFT**
– Fully depress bottom

SYSTEM SWITCH

NOTE: System switch **OFF** activates manual control.

- Preselect shift intent switch **DOWN** for low range.
- Preselect shift intent switch **UP** for hi range.
- Do not select range in **NEUTRAL**. Preselect in gear.
- Do not range shift while moving in **REVERSE**.

2297-C-7127

Refer to TP-95130 for more information



R-Ratio

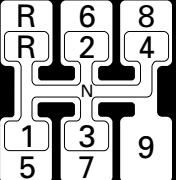

9-Speed Transmission

ENGINE SYNCHRO SHIFT

TO ACTIVATE ESS:

- Turn system switch to **ON**
- Depress clutch pedal
- Select starting gear

TO UP-SHIFT:

- Fully depress shift intent switch **UP** and release
- Immediately move lever to **NEUTRAL**
- Let engine synchronize
- Move lever into higher gear 2-3-4-5-6-7-8-9

TO DOWN-SHIFT:

- Fully depress shift intent switch **DOWN** and release
- Immediately move lever to **NEUTRAL**
- Let engine synchronize
- Move lever into lower gear 8-7-6-5-4-3-2-1

CLUTCH USE:

- Use clutch only for starting and stopping
- Depressing clutch disables engine synchronization
- System **OFF** requires use of clutch for shifting

SHIFT INTENT SWITCH



- **UPSHIFT**
– Fully depress top
- **DOWNSHIFT**
– Fully depress bottom

SYSTEM SWITCH

NOTE: System switch **OFF** activates manual control.

- Preselect shift intent switch **DOWN** for low range.
- Preselect shift intent switch **UP** for hi range.
- Do not select range in **NEUTRAL**. Preselect in gear.
- Do not range shift while moving in **REVERSE**.

2297-S-7247

Refer to TP-95130 for more information

10-Speed Models



ENGINE SYNCHRO SHIFT

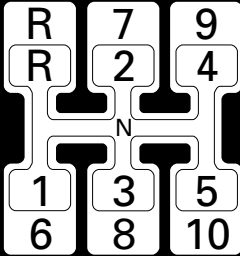

10-Speed Transmission

TO ACTIVATE ESS:

- Turn system switch to **ON**
- Depress clutch pedal
- Select starting gear

TO UP-SHIFT:

- Fully depress shift intent switch **UP** and release
- Immediately move lever to **NEUTRAL**
- Let engine synchronize
- Move lever into higher gear 2-3-4-5-6-7-8-9-10

TO DOWN-SHIFT:

- Fully depress shift intent switch **DOWN** and release
- Immediately move lever to **NEUTRAL**
- Let engine synchronize
- Move lever into lower gear 9-8-7-6-5-4-3-2-1

CLUTCH USE:

- Use clutch only for starting and stopping
- Depressing clutch disables engine synchronization
- System **OFF** requires use of clutch for shifting

SHIFT INTENT SWITCH

- **UPSHIFT**
– Fully depress top

- **DOWNSHIFT**
– Fully depress bottom

SYSTEM SWITCH

- NOTE:** System switch **OFF** activates manual control.
- Preselect shift intent switch **DOWN** for low range.
 - Preselect shift intent switch **UP** for hi range.
 - Do not select range in **NEUTRAL**. Preselect in gear.
 - Do not range shift while moving in **REVERSE**.



2297-B-7126

Refer to TP-95130 for more information



ENGINE SYNCHRO SHIFT

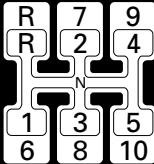

10-Speed Transmission

TO ACTIVATE ESS:

- Turn system switch to **ON**
- Depress clutch pedal
- Select starting gear

TO UP-SHIFT:

- Fully depress shift intent switch **UP** and release
- Immediately move lever to **NEUTRAL**
- Let engine synchronize
- Move lever into higher gear 2-3-4-5-6-7-8-9-10

TO DOWN-SHIFT:

- Fully depress shift intent switch **DOWN** and release
- Immediately move lever to **NEUTRAL**
- Let engine synchronize
- Move lever into lower gear 9-8-7-6-5-4-3-2-1

CLUTCH USE:

- Use clutch only for starting and stopping
- Depressing clutch disables engine synchronization
- System **OFF** requires use of clutch for shifting

NOTE: System switch **OFF** activates manual control.

- Preselect shift intent switch **DOWN** for low range.
- Preselect shift intent switch **UP** for hi range.
- Do not select range in **NEUTRAL**. Preselect in gear.
- Do not range shift while moving in **REVERSE**.

SHIFT INTENT SWITCH

- **UPSHIFT**
– Fully depress top

- **DOWNSHIFT**
– Fully depress bottom

SYSTEM SWITCH



2297-B-7246

Refer to TP-95130 for more information



MERITOR™
A Heritage of Rockwell Technology

Meritor Heavy Vehicle Systems, LLC
2135 West Maple Road
Troy, MI 48064 U.S.A.
800-535-5560
www.meritorauto.com

Information contained in this publication was in effect at the time the publication was approved for printing and is subject to change without notice or liability. Meritor Heavy Vehicle Systems, LLC, reserves the right to revise the information presented or discontinue the production of parts described at any time.

© Copyright 1998
Meritor Automotive, Inc.
All Rights Reserved

Printed
in the
USA

TP-95130
Revised 5-98
16579/24240